



R/V Mirai Cruise Report

MR15-03



Observational Studies on the Arctic Ocean Climate and Ecosystem Variability

Arctic Ocean, Bering Sea, and North Pacific Ocean

Leg 1: 24 August 2015 – 6 October 2015

Leg 2: 9 October 2015 – 22 October 2015

Japan Agency for Marine-Earth Science and Technology

(JAMSTEC)

Cruise Report ERRATA of the Nutrients part

page	Error	Correction
151	potassium nitrate CAS No. 7757-91-1	potassium nitrate CAS No. 7757-79-1
145	1N H ₂ SO ₄	1M H ₂ SO ₄

Contents

1. Cruise Summary	
1.1. Objectives	1
1.2. Overview	1
1.3. Basic information	3
1.4. Cruise tracks	3
1.5. List of participants	5
2. Meteorology	
2.1. GPS radiosonde	8
2.2. C-band weather radar	24
2.3. Surface meteorological observations	30
2.4. Disdrometers	41
2.5. Ceilometer	47
2.6. Greenhouse gasses	
2.6.1. Continuous measurements	51
2.6.2. Discrete flask sampling	52
2.6.3. Stable isotope measurements	55
2.7. Tropospheric gas and aerosol particles: Black carbon and others	57
2.8. Aerosol optical characteristics measured by ship-borne sky radiometer	59
2.9. Perfluoroalkyl substances (PFASs)	60
3. Physical Oceanography	
3.1. CTD cast and water samplings	66
3.2. XCTD	80
3.3. Underway CTD	83
3.4. Shipboard ADCP	89
3.5. Microstructure observations	92
3.6. Drifting buoys	103
3.7. Salinity measurements	106
3.8. Density	116
3.9. Moorings	132
4. Chemical and Biological Oceanography	
4.1. Dissolved oxygen	135

4.2. Nutrients	140
4.3. Dissolved Inorganic Carbon	
4.3.1. Bottled-water analysis	169
4.3.2. Underway DIC	173
4.4. Total alkalinity	175
4.5. Stable isotopes of water ($\delta^{18}\text{O}$ and δD)	180
4.6. Underway surface water monitoring	194
4.7. Dissolved greenhouse gases	
4.7.1. Continuous measurement of surface water for $p\text{CO}_2/p\text{CH}_4$ by CRDS	203
4.7.2. Discrete bottle sampling for CH_4 , N_2O and their isotopocules	205
4.7.3. Onboard measurements for CO_2 and CH_4 and their isotopomers	210
4.8. VOC/DMS	217
4.9. Perfluoroalkyl substances (PFASs)	222
4.10. Radionuclides	228
4.11. Chlorophyll <i>a</i>	230
4.12. Phytoplankton pigments	234
4.13. Optical measurements (PRR & LI-190R)	237
4.14. Primary production	239
4.15. New production	242
4.16. FRRF measurement	244
4.17. Plankton photographs	252
4.18. Sea water sampling for DNA sequence based plankton composition analysis and isolation of algal strains	255
4.19. Phytoplankton incubation	268
4.20. Plankton net, water sampling for microscopic observation, and biofouling of mooring equipment	272
4.21. Sediment trap	282
5. Geology	
5.1. Sea bottom topography measurements	290
5.2. Sea surface gravity measurements	292
5.3. Surface magnetic field measurements	
5.3.1. Three-components magnetometer	294
5.3.2. Cesium magnetometer	296
6. Notice on using	297

1. Cruise Summary

1.1. Objectives

In recent decades, the Arctic has rapidly lost its sea ice cover, and this could significantly amplify the upper ocean responses to atmospheric forcing that are associated with sea ice formation/melting, ocean circulation, mesoscale eddy formation and others. Such physical processes would change carbon and nutrient distributions in seawater, and might affect the lower trophic level ecosystem.

We focused on the ocean circulation and mesoscale eddies off Alaska (Chukchi/Beaufort seas and Canada Basin) and their influences to the biogeochemical and ecological processes. Furthermore, the cruise was planned to be extended to a Siberian side (excluding the Russian EEZs) to understand the Siberian shelf-basin interaction of water masses and its impact upon the biogeochemical and ecological processes (Unfortunately, the latter survey on the Siberian side was canceled because of a heavy sea ice condition).

1.2. Overview

In this cruise, to examine physical and chemical characteristics of an eddy that contains the Pacific-origin summer water in an area around the Barrow Canyon off the coast of Alaska, and to study the temporal variation of the eddy and its impact on the lower-trophic level ecosystem, we conducted ship-based observations of ADCP, TurboMAP (turbulent measurements), PRR (underwater spectral irradiance and radiance measurements), CTD/water samplings, XCTD, UCTD, GPS drifting buoys, and plankton nets. We also deployed a sediment trap in this area to investigate particle transports by the eddy. Furthermore, we recovered and re-deployed moorings to estimate transports of the Pacific-origin summer and winter waters and the associated heat and freshwater (salt) fluxes, and to study their seasonal variations.

On the other hand, in an area around the Hanna Canyon, a downstream area of the eddy passage, we conducted ship-based observations of TurboMAP (turbulent measurements), PRR (underwater spectral irradiance and radiance measurements), CTD/water samplings, and plankton nets to examine physical and chemical characteristics of the water there and distributions of phyto- and zooplanktons. Another sediment trap was deployed in this area to study the spatial variation of particles with the migration of the eddy. This area is also located in a passage of the Pacific-origin winter water. Thus, the sediment trap may capture the seasonal variation and an eddy formation of the winter water.

In the Chukchi Sea, we set an observation line along the $168^{\circ} 45'$ W meridian near the U.S.-Russia border from the Bering Strait to the shelf slope. Along this line, we conducted ship-based observations of TurboMAP (turbulent measurements), PRR (underwater spectral irradiance and radiance measurements), CTD/water samplings, and plankton nets to examine physical and chemical characteristics of waters and wide-area distributions of phyto- and zooplanktons from a biological hotspot in the

southern Chukchi Sea, where is one of the most biologically productive regions of the world's oceans, to a lower productive region in the northern end of the sea.

Along the cruise track, we performed observations of radiosonde, Doppler radar, general meteorology, air sampling, sky radiometer, MAX-DOAS (Multi-Axis – Differential Optical Absorption Spectroscopy), disdrometers, sea surface water monitoring, sea bottom topography, gravity, and magnetic fields. In addition, magnetic total force intensity was measured by towing an instrument, Cesium precession magnetometer, in the North Pacific Ocean.

Note that the field experiment in an area off the coast of Siberia, where the data are extremely scarce, was canceled due to a heavy sea ice condition.

This cruise included the following publicly-offered studies:

- Studies on board

- Representative of the Science Party [Affiliation]: Shigeto Nishino [JAMSTEC]
- Title of proposal: Observational studies on the Arctic Ocean climate and ecosystem variability
- Representative of the Science Party [Affiliation]: Nobuyoshi Yamashita [National Institute of Advanced Industrial Science and Technology]
- Title of proposal: Estimation of hazardous chemicals discharge from the melting ice in the Arctic Ocean
- Representative of the Science Party [Affiliation]: Koji Hamasaki [Atmosphere and Ocean Research Institute, The University of Tokyo]
- Title of proposal: Studies on microbial production variability and dinitrogen fixation in the ecosystem of rapidly changing Arctic Ocean
- Representative of the Science Party [Affiliation]: Masao Ishii [Meteorological Research Institute]
- Title of proposal: Studies on the dynamics of greenhouse gases and volatile organic compounds in the Arctic Ocean

- Studies not on board

- Representative of the Science Party [Affiliation]: Kazuma Aoki [Toyoma University]
- Title of proposal: Aerosol optical characteristics measured by Ship-borne Sky radiometer
- Representative of the Science Party [Affiliation]: Yugo Kanaya [JAMSTEC]
- Title of proposal: Advanced measurements of aerosols in the marine atmosphere: Toward elucidation of interactions with climate and ecosystem
- Representative of the Science Party [Affiliation]: Masaki Katsumata [JAMSTEC]
- Title of proposal: Global distribution of drop size distribution of precipitating particles over pure-oceanic background
- Representative of the Science Party [Affiliation]: Masao Nakanishi [Chiba University]
- Title of proposal: Tectonic history of the Pacific Plate during mid-Cretaceous

1.3. Basic information

Name of vessel	R/V Mirai L x B x D 128.58m x 19.0m x 13.2m Gross Tonnage: 8,706 tons Call Sign JNSR
Cruise code	MR15-03
Undertaking institute	Japan Agency for Marine-Earth Science and Technology (JAMSTEC)
Chief scientist	Shigeto Nishino Japan Agency for Marine-Earth Science and Technology (JAMSTEC)
Cruise periods	Leg 1: 24 August 2015 – 6 October 2015 Leg 2: 9 October 2015 – 22 October 2015
Ports call	24 August 2015, Sekinehama (leave port) 24 August 2015, Hachinohe (arrival in port) 26 August 2015, Hachinohe (leave port) 6 October 2015, Dutch Harbor (arrival in port) 9 October 2015, Dutch Harbor (leave port) 21 October 2015, Hachinohe (arrival in and leave port) 22 October 2015, Sekinehama (arrival in port)
Research areas	The North Pacific Ocean, the Bering Sea, and the Arctic Ocean

1.4. Cruise tracks

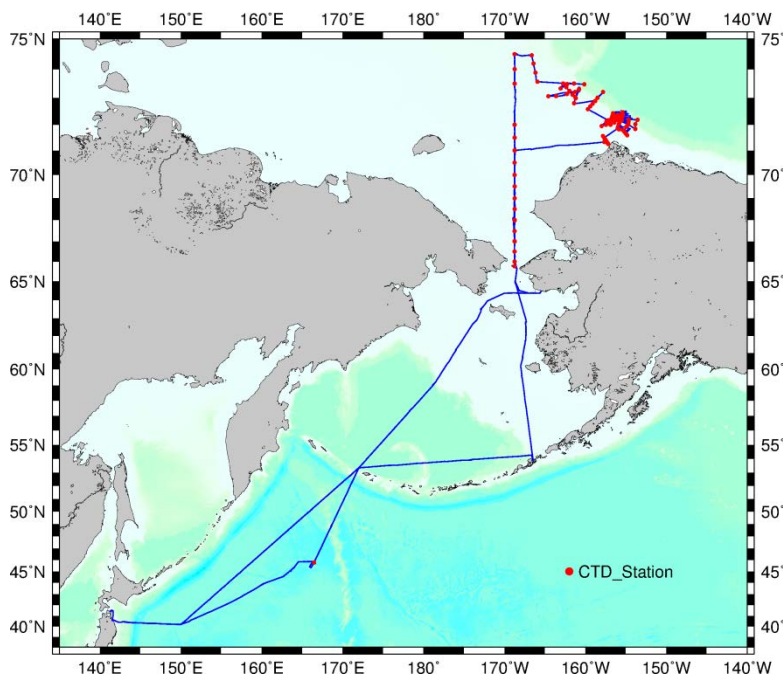

Figure 1.4-1: Cruise tracks and CTD stations of MR15-03.

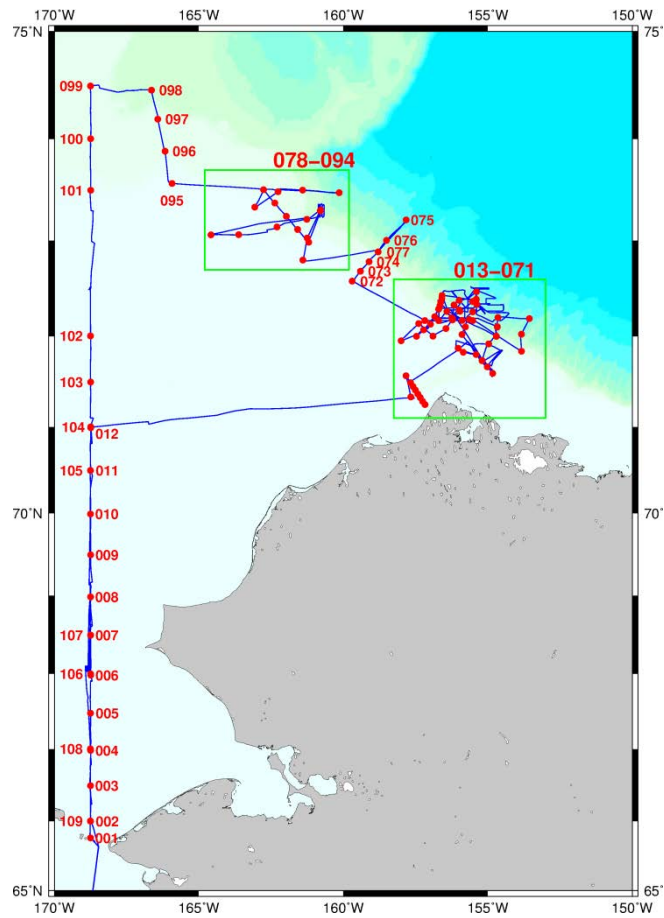

Figure 1.4-2: Cruise tracks and CTD stations north of 65°N .

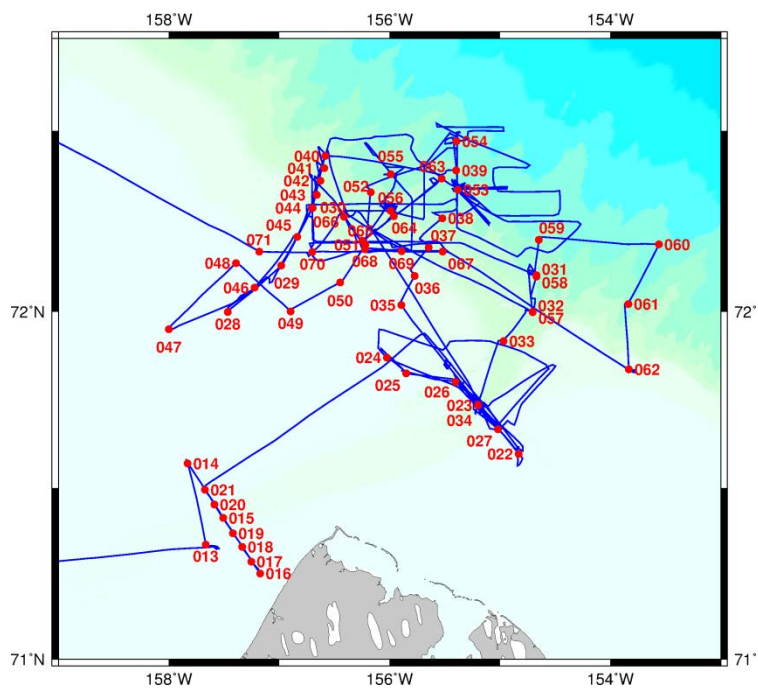

Figure 1.4-3: Cruise tracks and CTD stations around Barrow Canyon (Sta. 013-071).

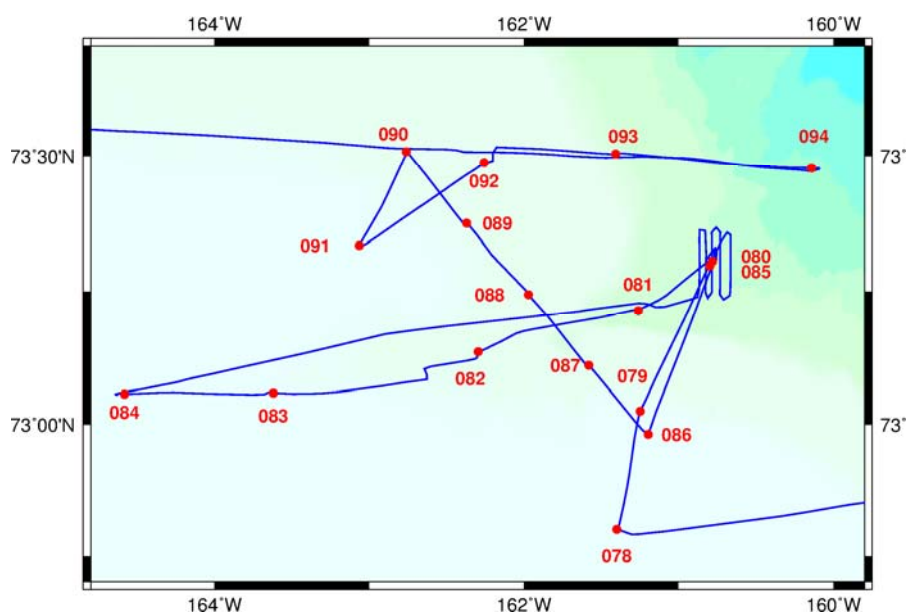

Figure 1.4-4: Cruise tracks and CTD stations around Hanna Canyon (Sta. 078-094).

1.5. List of participants

Table 1.5.1: List of participants of MR15-03 Leg 1.

No.	Name	Organization	Position
1	Shigeto Nishino	JAMSTEC	Research scientist
2	Kazuhiro Oshima	JAMSTEC	Research scientist
3	Yoshimi Kawai	JAMSTEC	Research scientist
4	Yusuke Kawaguchi	JAMSTEC	Research scientist
5	Amane Fujiwara	JAMSTEC	Research scientist
6	Jonaotaro Onodera	JAMSTEC	Research scientist
7	Koji Sugie	JAMSTEC	Research scientist
8	Fumihiro Itoh	JAMSTEC / Tsukuba University	Research student / Graduate student
9	Hiroki Takeda	JAMSTEC / Tokyo Gakugei University	Research student / Graduate student
10	Yuki Ito	Meiji University	Graduate student
11	Hui Ge	AIST / Kanazawa University	Technological trainee / Graduate student
12	Takuhei Shiozaki	The University of Tokyo	JSPS postdoctoral fellow
13	Minoru Ijichi	The University of Tokyo	Project researcher
14	Sohiko Kameyama	Hokkaido University	Associate professor
15	Mahomi Inagawa	Hokkaido University	Graduate student

16	Shinya Okumura	Global Ocean Development Inc.	Technical Staff
17	Wataru Tokunaga	Global Ocean Development Inc.	Technical Staff
18	Koichi Inagaki	Global Ocean Development Inc.	Technical Staff
19	Yutaro Murakami	Global Ocean Development Inc.	Technical Staff
20	Tomohide Noguchi	Marine Works Japan Ltd.	Technical Staff
21	Tatsuya Tanaka	Marine Works Japan Ltd.	Technical Staff
22	Shinsuke Toyoda	Marine Works Japan Ltd.	Technical Staff
23	Rei Ito	Marine Works Japan Ltd.	Technical Staff
24	Sonoka Wakatsuki	Marine Works Japan Ltd.	Technical Staff
25	Masanori Enoki	Marine Works Japan Ltd.	Technical Staff
26	Yasuhiro Arii	Marine Works Japan Ltd.	Technical Staff
27	Tomonori Watai	Marine Works Japan Ltd.	Technical Staff
28	Emi Deguchi	Marine Works Japan Ltd.	Technical Staff
29	Masahiro Orui	Marine Works Japan Ltd.	Technical Staff
30	Keitaro Matsumoto	Marine Works Japan Ltd.	Technical Staff
31	Hiroshi Hoshino	Marine Works Japan Ltd.	Technical Staff
32	Yoshiki Kido	Marine Works Japan Ltd.	Technical Staff
33	Keisuke Matsumoto	Marine Works Japan Ltd.	Technical Staff
34	Keisuke Takeda	Marine Works Japan Ltd.	Technical Staff
35	Yoshiko Ishikawa	Marine Works Japan Ltd.	Technical Staff
36	Makoto Takada	Marine Works Japan Ltd.	Technical Staff
37	Elena Hayashi	Marine Works Japan Ltd.	Technical Staff
38	Tomomi Sone	Marine Works Japan Ltd.	Technical Staff
39	Shinichiro Yokogawa	Marine Works Japan Ltd.	Technical Staff
40	Hironori Sato	Marine Works Japan Ltd.	Technical Staff
41	Misato Kuwahara	Marine Works Japan Ltd.	Technical Staff
42	Haruka Tamada	Marine Works Japan Ltd.	Technical Staff
43	Nobuhiro Anraku	Marine Works Japan Ltd.	Technical Staff
44	Kenzaburo Sawano	Marine Works Japan Ltd.	Technical Staff
45	David Duke Snider	Martech Polar Consulting Ltd.	Ice Pilot

Table 1.5.2: List of participants of MR15-03 Leg 2.

No.	Name	Organization	Position
1	Shigeto Nishino	JAMSTEC	Research scientist
2	Kazuhiro Oshima	JAMSTEC	Research scientist
3	Yoshimi Kawai	JAMSTEC	Research scientist
4	Yusuke Kawaguchi	JAMSTEC	Research scientist
5	Amane Fujiwara	JAMSTEC	Research scientist
6	Hiroki Takeda	JAMSTEC / Tokyo Gakugei University	Research student / Graduate student
7	Yuki Ito	Meiji University	Graduate student
8	Hui Ge	AIST / Kanazawa University	Technological trainee / Graduate student

9	Soichiro Sueyoshi	Global Ocean Development Inc.	Technical Stuff
10	Yutaro Murakami	Global Ocean Development Inc.	Technical Stuff
11	Tomohide Noguchi	Marine Works Japan Ltd.	Technical Stuff
12	Tatsuya Tanaka	Marine Works Japan Ltd.	Technical Stuff
13	Shinsuke Toyoda	Marine Works Japan Ltd.	Technical Stuff
14	Rei Ito	Marine Works Japan Ltd.	Technical Stuff
15	Sonoka Wakatsuki	Marine Works Japan Ltd.	Technical Stuff
16	Masanori Enoki	Marine Works Japan Ltd.	Technical Stuff
17	Yasuhiro Arii	Marine Works Japan Ltd.	Technical Stuff
18	Tomonori Watai	Marine Works Japan Ltd.	Technical Stuff
19	Emi Deguchi	Marine Works Japan Ltd.	Technical Stuff
20	Masahiro Orui	Marine Works Japan Ltd.	Technical Stuff
21	Keitaro Matsumoto	Marine Works Japan Ltd.	Technical Stuff
22	Yoshiki Kido	Marine Works Japan Ltd.	Technical Stuff

2. Meteorology

2.1. GPS radiosonde

(1) Personnel

Kazuhiro Oshima	JAMSTEC	- PI
Yoshimi Kawai	JAMSTEC	
Masatake Hori	JAMSTEC	- not on board
Jun Inoue	JAMSTEC / NIPR	- not on board
Shinya Okumura	GODI	
Souichiro Sueyoshi	GODI	
Wataru Tokunaga	GODI	
Koichi Inagaki	GODI	
Yutaro Murakami	GODI	
Masanori Murakami	MIRAI Crew	

(2) Objectives

To understand the thermodynamic structure of the boundary layer, and migratory cyclones and anticyclones, a 6-hourly radiosonde observation was conducted over the Arctic Ocean and the Bering Sea during 6 September – 5 October 2014. The dataset also includes 12-hourly observations conducted over the Bering Sea and the Northwestern Pacific Ocean during 27 August – 5 September and 11-20 October. Obtained data will be used mainly for studies of clouds, the boundary layer, and validation of reanalysis data as well as satellite analysis, and data assimilation.

We also launched the latest type of radiosonde (RS41-SGP) by directly connecting with the previous type (RS92-SGPD) 18 times to check biases between them.

(3) Parameters

Atmospheric soundings of temperature, humidity, and wind speed/direction.

(4) Instruments and methods

Usual atmospheric soundings were carried out using the previous type of GPS radiosonde (RS92-SGPD). For the usual soundings, the receiving system consisted of a new software (MW41), processor (SPS331), GPS antenna (GA20), UHF antenna (RB21) and balloon launcher (ASAP) manufactured by Vaisala Oyj. Prior to launch, humidity, air temperature, and pressure sensors were calibrated by using the calibrator system (GC25 and PTB330). In case the relative wind to the ship is not appropriate for the launch, the hand launch was selected.

When the latest type of radiosonde (RS41-SPG) were also launched together with an RS92 radiosonde, the above receiving system and a new calibrator (RI41) in the radiosonde container were used for RS-41. For RS92, another receiving system with a previous software (MW31), processor (SPS311), GPS antenna (GA31) and UHF antenna

(RM32) were used in the aft wheelhouse. The hand launch was always selected when both the RS41 and RS92 were simultaneously released. 350-g balloons were used for the simultaneously launches. Note that users should subtract 0.18 hPa from pressure values for five of RS92 radiosondes (ID: RS002b, RS004b, RS006b, RS010b, and RS011) because the barometer PTB330 used for calibration in the aft wheelhouse had a bias of 0.18 hPa compared with another one used in the radiosonde container. (The RS92 radiosonde of ID: RS011 was prepared with the previous software in the aft wheelhouse.) And, for ID: RS060a and b at 06 UTC on 16 September, there seemed to be a large difference in the automatically decided release time between RS41 and RS92 (see (6)).

(5) Station list or Observation log

Table 2.1-1 summarizes the log of the soundings. All data were sent to the world meteorological community by the global telecommunication system (GTS) through the Japan Meteorological Agency immediately after each observation. Raw data were recorded as binary format during ascent. ASCII data were converted from raw data.

(6) Preliminary results

Location of all the radiosonde observations during the cruise is shown in Figure 2.1-1. Time-height section of observed relative humidity, air temperature and wind during the cruise are shown in Figure 2.1-2. The northerly wind was continuously blowing near the surface from 6 to 9 September, the Bering Strait to off Barrow. The boundary layer became thicker and the cloud base height became higher gradually throughout this period, perhaps due to the heating from the sea surface.

We examined differences between different types of GPS radiosonde, RS92 and RS41, by directly connecting and simultaneously launching them (Figure 2.1-3). Figure 2.1-4 shows differences of pressure, temperature, relative humidity, and wind speed, and mean differences (biases) and standard deviations are summarized in Table 2.1-2. There were quite large differences in observations at 06 UTC on 16 September (ID: RS060a and b), because the release time of RS41, which was automatically decided, seemed to be too early compared to that of RS92. The release time of RS41 was manually corrected only for ID: RS060a when calculating biases. The differences were calculated with reference to time or altitude. The biases of temperature and wind speed were small enough, although the difference of temperature was occasionally quite large. The relative humidity of RS41 was higher than that of RS92 on average, and the difference tended to be larger in the upper troposphere. The pressure of RS41 was higher by about 0.1 hPa than that of RS92 when the values were compared at the same altitude (Figure 2.1-4a). On the other hand, the former became lower than the latter as the radiosondes rose up when the differences were calculated at the same time step (Figure 2.1-4i). This was because the difference of height became larger as time passed (Figure 2.1-5). The difference of pressure tended to be slightly larger in the range of

10-20 m/s of wind speed.

(7) Data archives

These data obtained in this cruise will be submitted to the Data Management Group of JAMSTEC, and will be opened to the public via “Data Research System for Whole Cruise Information in JAMSTEC (DARWIN)” in JAMSTEC web site.

<<http://www.godac.jamstec.go.jp/darwin/e>>

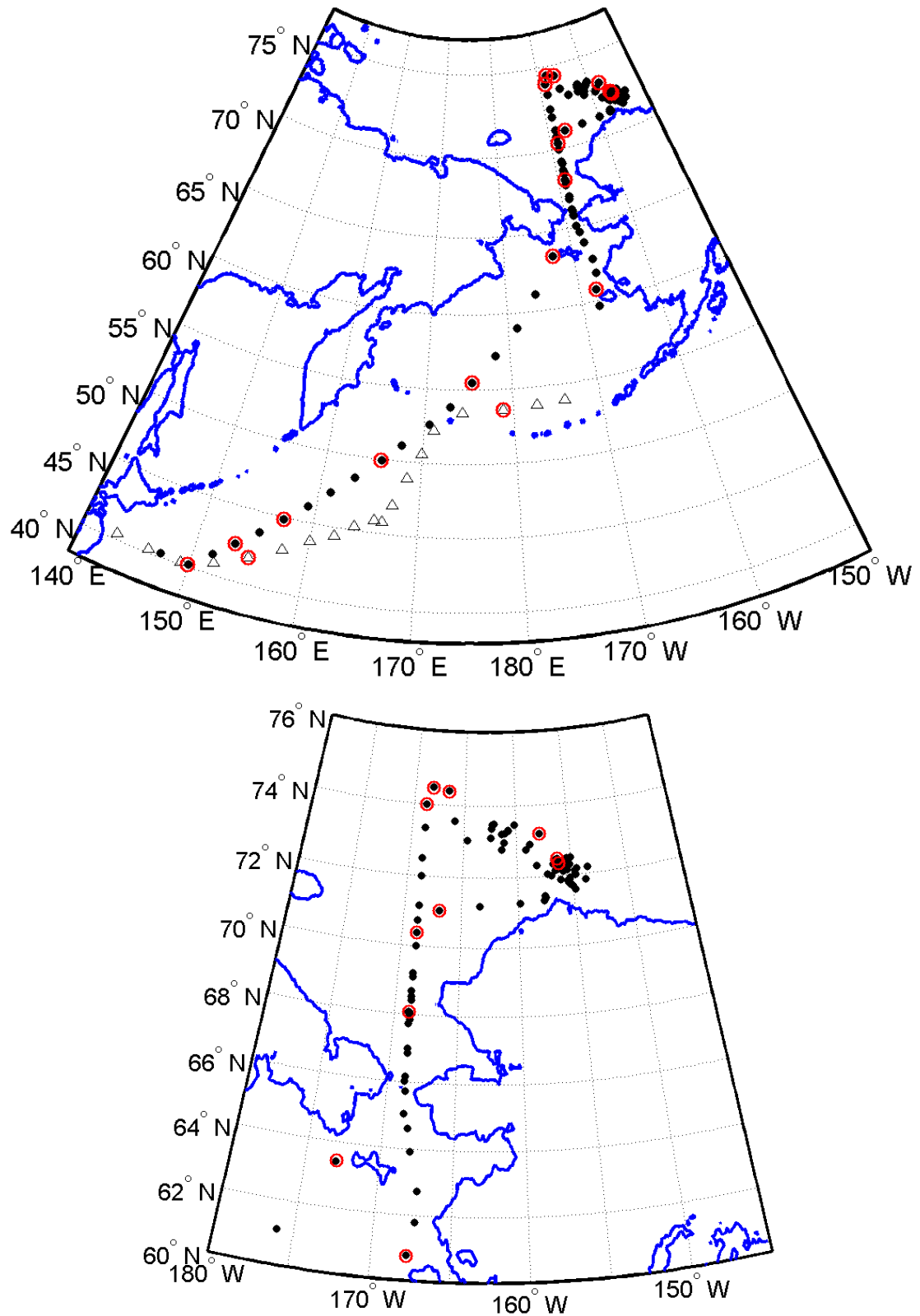

Figure 2.1-1: (upper) Locations of GPS radiosonde observations. (lower) Enlarged map of the Arctic Sea. Black dot and black triangle denote RS92 in leg-1 and leg-2, respectively. Red circle denotes RS41.

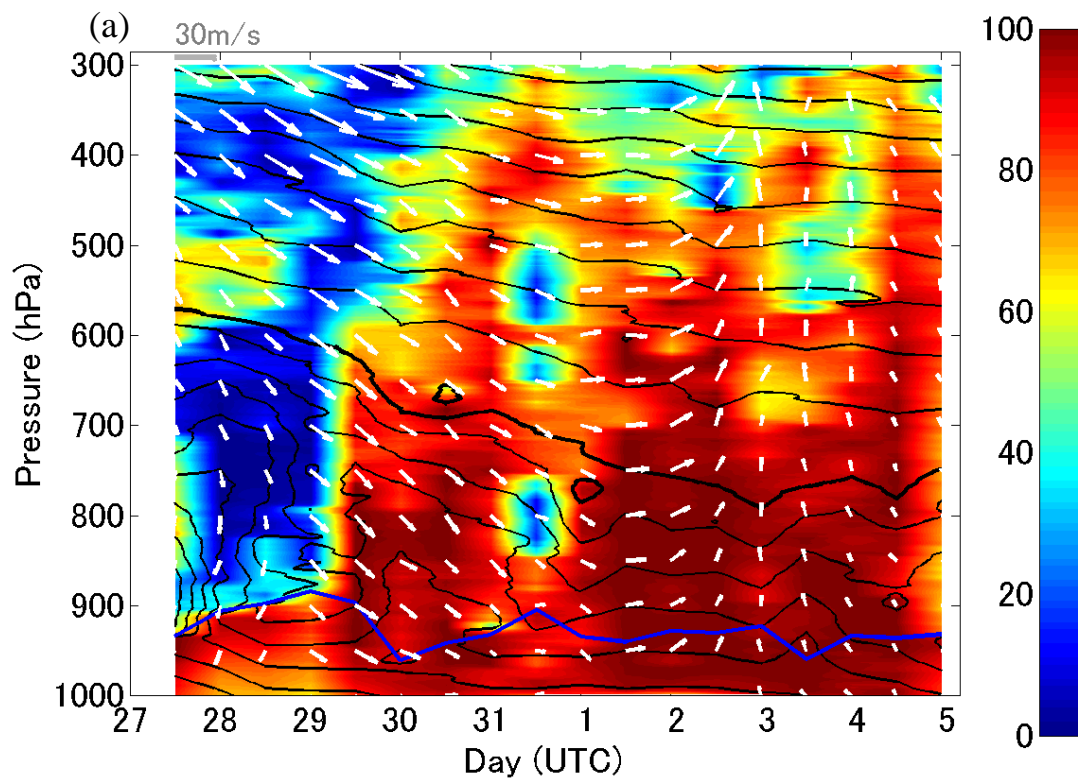

Figure 2.1-2: Time-height section of relative humidity (color), air temperature (black contours) and wind (vectors). Black bold contour denotes 0 °C. Contour interval is 5 °C (2 °C) when the temperature is less (more) than 0 °C. Blue contour shows the mixed layer height defined as the height where potential temperature is higher by 2.0 °C than the surface. (a) 27 August – 5 September (leg 1, every 12 hours), (b) 6–20 September (leg 1, every 6 hours), (c) 21 September – 5 October (leg 1, every 6 hours), and (d) 11–20 October (leg 2, every 12 hours).

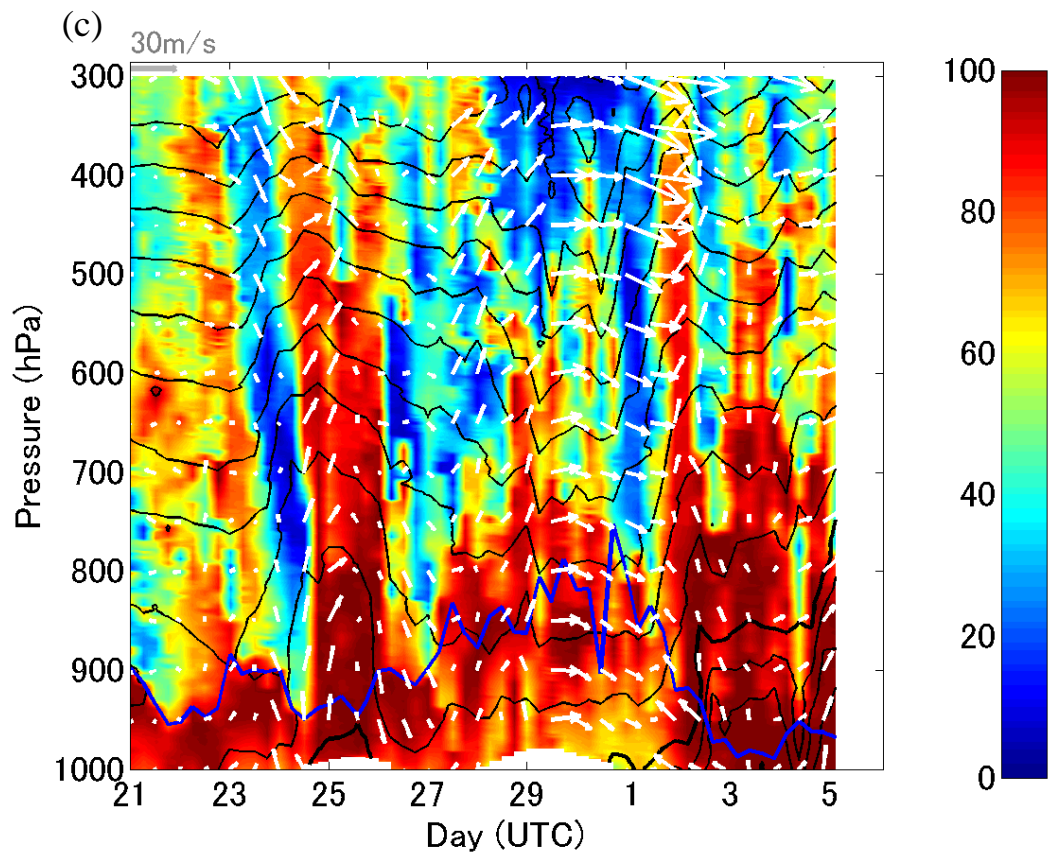
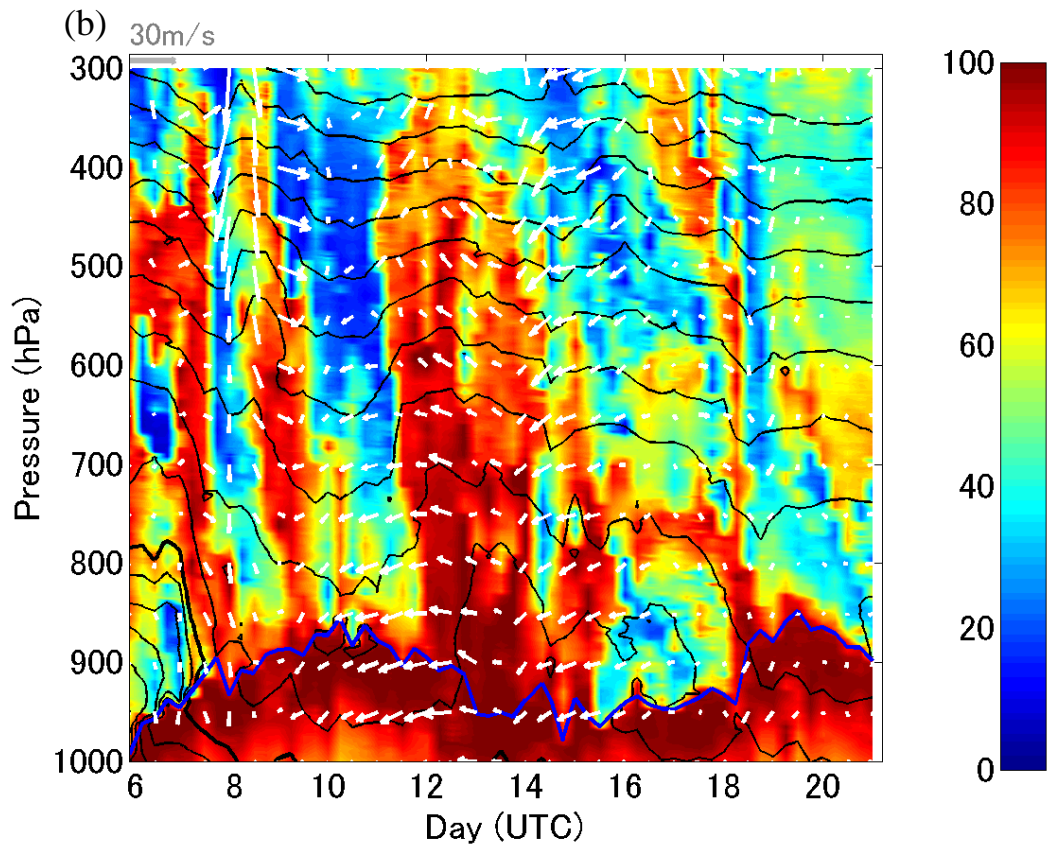

Figure 2.1-2, continued

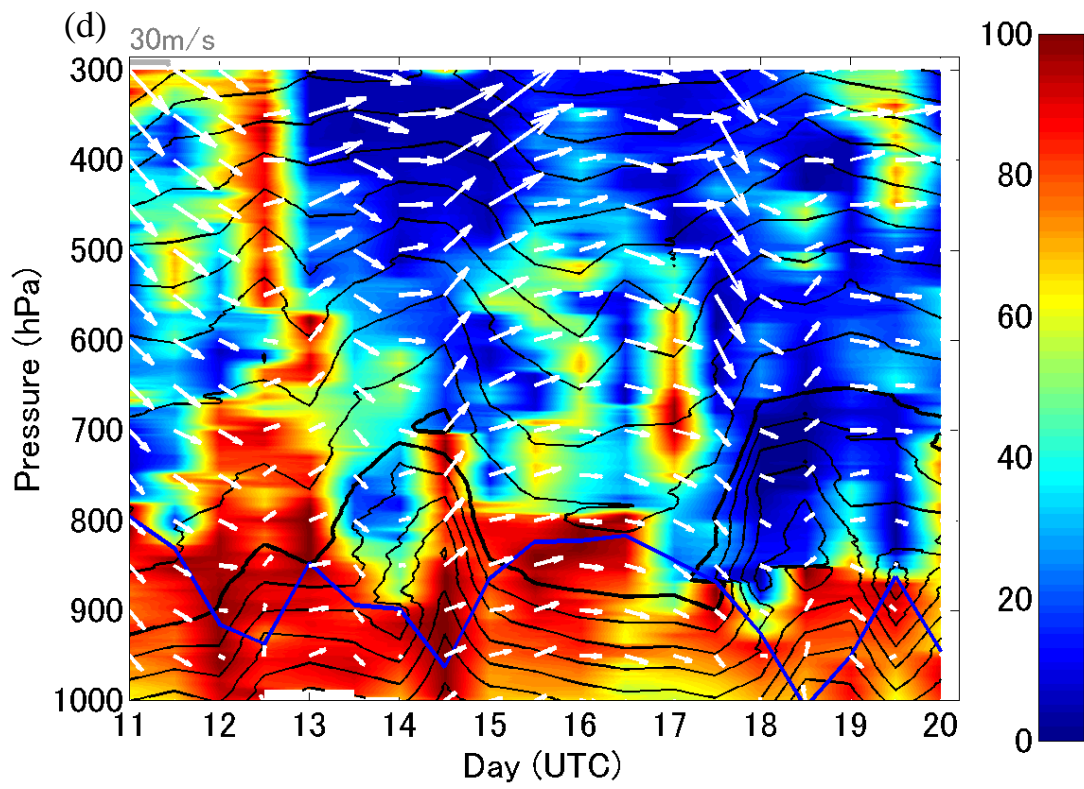

Figure 2.1-2, continued



Figure 2.1-3: Photo of an RS41-type radiosonde connected with an RS92-type one

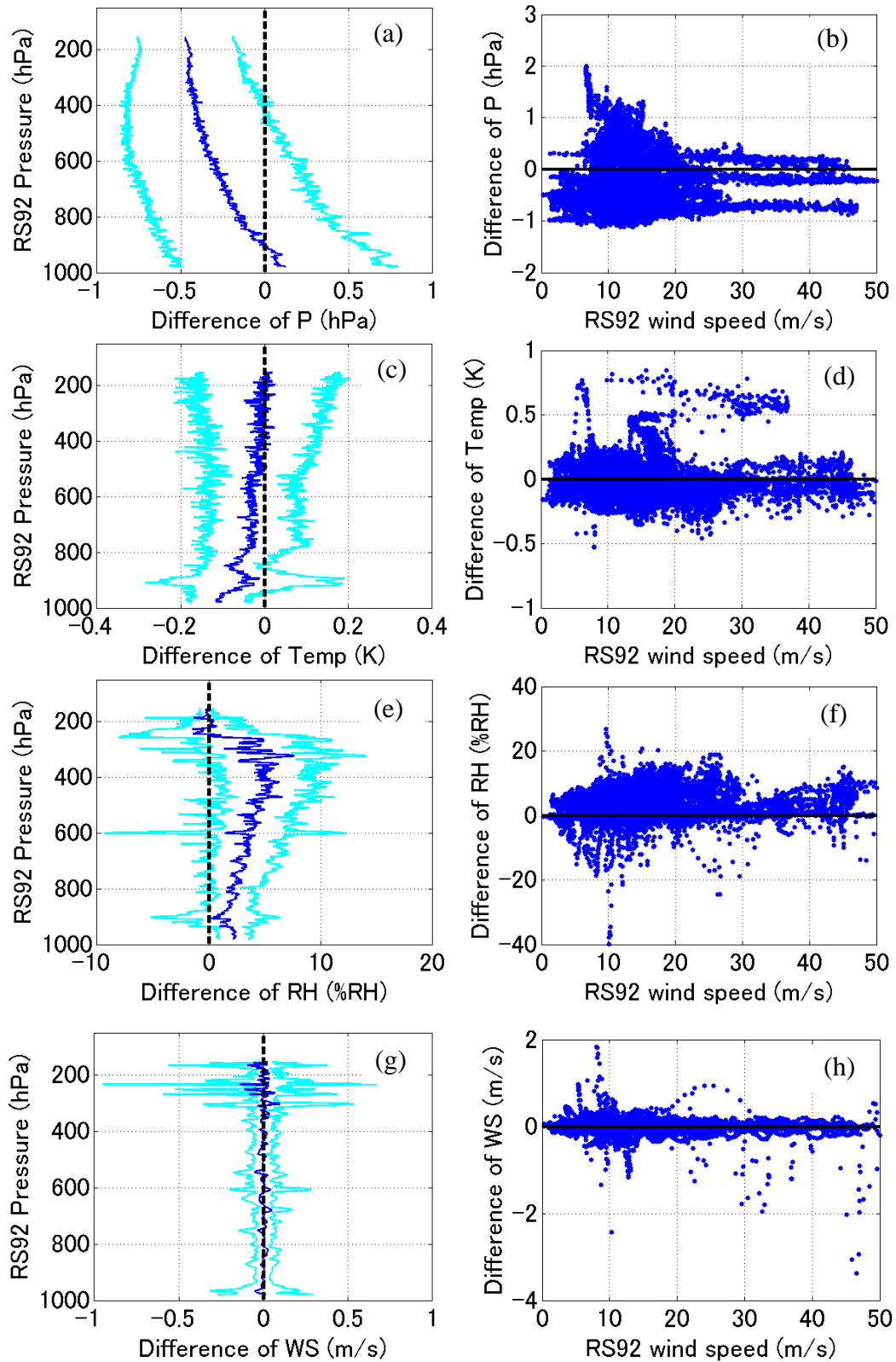

Figure 2.1-4: Mean differences of (a, b, i, j) pressure, (c, d, k, l) temperature, (e, f, m, n) relative humidity, and (g, h, o, p) wind speed between RS92-SGPD and RS41-SGP. Differences were calculated at the same (a-h) observation time or (i-p) altitude. Blue and cyan lines in the left panels denote mean difference and standard deviation.

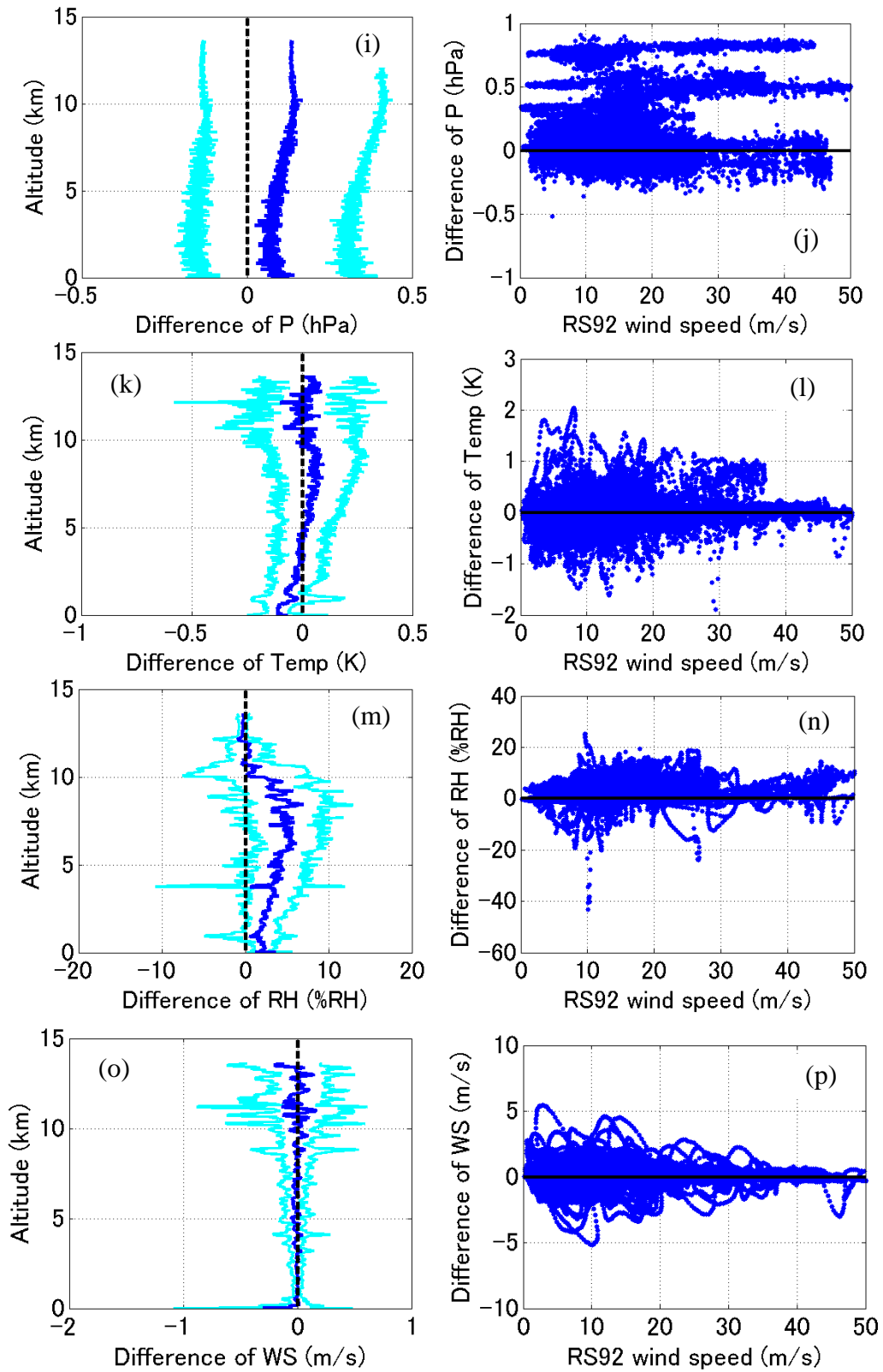

Figure 2.1-4, continued

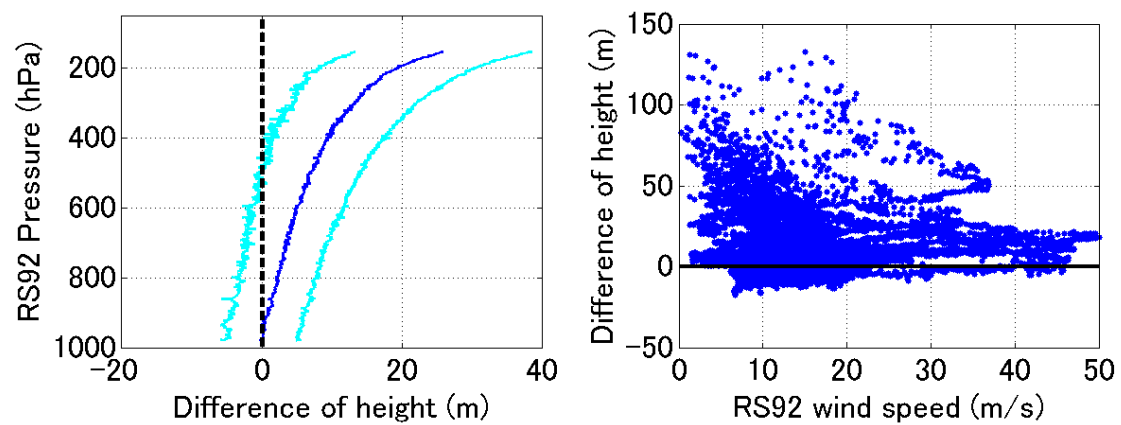

Figure 2.1-5: Mean difference of altitude between RS92-SGPD and RS41-SGP. Differences were calculated at the same observation time. Blue and cyan lines in the left panels denote mean difference and standard deviation.

Table 2.1-1: Launch log.

Note: For the connected launches (hatched), RS41 and RS92 are denoted by *a* and *b*, respectively.

The RS92 radiosonde of ID: RS011 was prepared with the previous software in the aft wheelhouse.

ID	SN	Date	Latitude	Longitude	Psf	Tsfc	RH sfc	WD	Wsp	SST	Max height			Cloud	
		YYYYMMDD HH	°N	°E	hPa	°C	%	deg	m/s	C	hPa	m	Dura tion	Amo unt	Typ e
RS001	K4124457	2015082712	40.24532	147.36211	1011.7	16.8	80	64	8.7	17.19	35.6	23145	1:37:24	9	Sc
RS002a	L2210139	2015082800	40.16984	149.94440	1011.7	15.9	69	23	7.1	20.41	20.5	26734	1:49:51	5	Cu Sc
RS002b	L1713326	2015082800	40.16920	149.97100	1011.7	15.9	69	23	7.1	20.41	20.8	26603	1:49:48	5	Cu Sc
RS003	K4124422	2015082812	41.32447	151.72910	1012.5	13.7	68	31	8.1	15.34	53.0	20607	1:17:39	5	Sc
RS004a	L2210203	2015082900	42.42345	153.41341	1010.7	14.0	70	306	11.2	15.47	34.6	23328	1:28:02	3	Cu
RS004b	L1526103	2015082900	42.42360	153.41400	1010.7	14.0	70	306	11.2	15.47	35.2	23217	1:28:02	3	Cu
RS005	K4034334	2015082912	43.60112	155.26164	1005.3	13.1	80	296	16.4	14.41	34.4	23367	1:40:35	7	Sc
RS006a	L2210010	2015083000	44.83101	157.19257	1004.2	12.1	93	289	11.6	12.11	45.2	21607	1:20:51	10	Sc, Ac, As
RS006b	K3943868	2015083000	44.83590	157.20000	1004.2	12.1	93	289	11.6	12.11	45.9	21491	1:20:50	10	Sc, Ac, As
RS007	K4124428	2015083012	46.07647	159.21053	1003.7	11.3	92	277	13.3	11.94	34.8	23259	1:36:38	10	Sc, St
RS008	K4124425	2015083100	47.26426	161.17426	1001.8	10.9	90	340	4.4	10.85	28.4	24518	1:37:32	9	Sc, St
RS009	K4124438	2015083112	48.51034	163.28795	1001.1	10.6	90	265	6.3	11.04	44.9	21570	1:32:18	5	Sc, Ci
RS010a	L2210093	2015090100	49.93106	165.75325	999.6	10.9	93	275	5.6	10.85	63.2	19380	1:08:05	9	Sc, Cu
RS010b	L1526124	2015090100	49.94140	165.77200	999.6	11.9	93	275	5.6	11.85	63.8	19303	1:08:06	9	Sc, Cu
RS011	K4124164	2015090112	51.05030	167.76800	999.6	10.4	95	244	13.5	10.94	42.4	21936	5314	10	-
RS012	K4034306	2015090200	52.59331	170.62445	999.6	11.0	91	218	7.8	10.77	29.9	24226	1:41:57	10	St
RS013	K4123448	2015090212	53.86737	172.83141	999.0	10.5	93	195	9.1	10.74	37.5	22727	1:49:01	10	-
RS014a	L2210150	2015090300	55.49283	175.34213	1000.4	10.3	97	155	7.8	10.55	151.9	13617	0:48:29	10	St
RS014b	K4123657	2015090300	55.49530	175.34600	1000.4	10.3	97	155	7.8	10.55	152.0	13607	0:48:28	10	St
RS015	K4124434	2015090312	57.25558	178.20139	1001.9	10.0	100	149	5.8	10.20	33.2	23502	1:44:39	-	-
RS016	K4124411	2015090400	58.99122	-178.83130	1004.0	9.6	96	148	7.0	10.34	30.0	24173	1:43:54	10	Sc, St
RS017	K4124463	2015090412	61.08467	-176.08240	1006.7	9.3	97	161	3.1	9.77	39.5	22375	1:44:27	-	-
RS018a	L2210148	2015090500	63.42941	-172.91656	1008.6	9.0	81	294	3.6	9.46	33.0	23554	1:17:38	8	Sc
RS018b	K4123447	2015090500	63.42440	-172.91600	1008.6	9.0	81	294	3.6	9.46	33.8	23361	1:17:38	8	Sc
RS019	K4133223	2015090600	64.62365	-168.30832	1012.6	7.0	99	4	8.5	7.33	42.8	21848	1:40:15	10	St
RS020	K4124449	2015090606	65.71771	-168.64697	1015.3	5.8	94	9	12.7	7.97	31.2	23879	1:41:03	10	St
RS021	L1526118	2015090612	66.16470	-168.75385	1016.6	4.4	96	348	8.0	6.86	59.3	19720	1:27:49	-	-
RS022	L1526125	2015090618	67.00161	-168.74980	1016.2	4.7	89	354	7.2	6.77	35.4	23047	2:04:45	10	Sc, St
RS023	L1526078	2015090700	67.83459	-168.74985	1016.0	4.4	91	351	7.8	4.68	37.2	22736	1:41:52	10	Sc, St
RS024	L1526107	2015090706	68.42522	-168.74847	1015.7	4.1	86	348	7.8	6.03	73.0	18328	1:21:06	10	Sc
RS025	L1526115	2015090712	69.09535	-168.75638	1015.7	3.8	75	359	7.1	7.83	39.8	22245	1:39:52	-	-
RS026	L1526111	2015090718	69.99922	-168.74962	1015.8	2.9	84	349	8.6	5.31	48.7	20919	1:17:24	9	Sc
RS027	L1526076	2015090800	70.72701	-168.75652	1016.4	2.6	85	355	8.8	4.72	43.8	21582	1:19:40	10	Sc, St
RS028a	L2210204	2015090806	71.05390	-166.93704	1015.9	1.3	83	342	6.7	6.57	35.9	22872	1:13:05	7	Sc, Ci
RS028b	K4124420	2015090806	71.05370	-166.94400	1015.9	1.3	83	342	6.7	6.57	36.6	22731	1:13:02	7	Sc, Ci
RS029	L1526102	2015090812	71.19612	-163.40607	1013.4	0.3	78	347	3.9	4.07	77.3	17843	1:19:54	-	-
RS030	L1526095	2015090818	71.26498	-159.82907	1010.1	0.3	81	5	3.6	5.39	38.8	22305	1:35:24	8	Sc, Ci
RS031	L1526134	2015090900	71.33408	-157.66618	1007.9	0.9	76	278	2.1	5.15	53.3	20230	1:33:18	9	Sc, St, As
RS032	K4123653	2015090906	71.41559	-157.50777	1006.4	1.0	86	92	6.4	5.43	33.5	23224	2:07:00	10	Sc, Cu Ac
RS033	L1713331	2015090912	71.44968	-157.58351	1008.5	-0.2	74	63	10.3	5.46	42.2	21708	1:28:23	-	-
RS034	L1526143	2015090918	71.83994	-155.47026	1010.5	-0.9	75	54	9.7	4.68	102.3	15879	1:07:35	10	Sc, St
RS035	L1526116	2015091000	71.75355	-155.20406	1012.2	-1.4	75	34	9.0	4.79	43.1	21544	1:28:53	10	Sc, St
RS036	L1525144	2015091006	71.67492	-154.98476	1011.9	-0.1	74	56	10.9	5.19	54.0	20072	1:31:49	10	Sc

RS037	K4053344	2015091012	71.72314	-155.21437	1012.0	-0.9	68	53	10.0	4.84	121.3	14739	1:00:42	-	-
RS038	K4053354	2015091018	71.73091	-155.16054	1011.1	-0.5	70	76	12.7	4.99	47.0	20964	1:21:29	10	Se, St
RS039	K4053353	2015091100	71.79842	-155.35794	1010.2	-0.5	76	51	14.2	4.18	43.7	21427	1:22:08	10	Se
RS040	K4053351	2015091106	71.91866	-155.24464	1009.1	-0.6	78	63	14.1	4.02	39.8	22040	1:32:56	10	Se
RS041	K4053355	2015091112	71.58244	-154.79688	1007.2	-1.2	81	46	12.4	2.93	48.4	20766	1:24:01	-	-
RS042	K4053362	2015091118	71.71983	-155.16679	1007.2	-0.2	84	63	16.0	5.29	46.2	21061	1:21:22	10	St
RS043	K4053349	2015091200	71.88680	-156.04691	1008.8	0.1	84	75	13.6	5.40	40.0	22025	1:22:34	10	St
RS044	K4123664	2015091206	71.78506	-155.32852	1008.0	0.0	92	69	16.4	3.78	35.7	22752	1:26:44	10	St
RS045	K4123671	2015091212	72.22791	-156.16229	1009.9	-0.4	92	62	13.2	4.16	67.3	18619	1:12:12	-	-
RS046	K4124161	2015091218	72.06170	-157.24432	1008.1	0.9	94	87	16.0	4.11	42.7	21595	1:22:02	10	St
RS047a	L2130535	2015091300	72.47625	-156.28906	1009.8	-0.1	96	91	9.3	1.28	45.3	21243	1:06:00	10	St
RS047b	K4123442	2015091300	72.47630	-156.28900	1009.8	-0.1	96	91	9.3	1.28	45.8	21151	1:06:00	10	St
RS048	K4053356	2015091306	72.16535	-154.53883	1008.4	0.3	98	88	10.8	1.65	36.5	22628	1:34:24	10	St
RS049	K4123433	2015091312	72.19233	-156.18060	1007.5	1.0	99	88	6.7	1.62	53.8	20096	1:23:12	-	-
RS050	K4123245	2015091318	72.10912	-154.74725	1006.6	0.1	99	56	8.8	1.76	35.7	22751	1:27:05	10	St
RS051	K4123445	2015091400	72.00023	-154.72624	1004.6	0.0	96	50	9.7	2.13	45.4	21195	1:25:11	10	St
RS052	K4124160	2015091406	71.74570	-155.19333	1003.0	0.4	94	54	11.0	3.09	37.9	22379	1:30:44	10	St, Se
RS053	K4123446	2015091412	72.10746	-155.78703	1003.8	0.0	93	38	11.0	3.38	43.7	21442	1:32:33	-	-
RS054	K4123672	2015091418	72.27178	-155.58827	1004.7	-0.9	97	47	11.9	1.65	39.9	22000	1:27:23	6	St
RS055	K4123683	2015091500	72.39225	-155.43315	1007.6	0.0	96	46	12.0	1.22	37.7	22366	1:33:16	10	St
RS056	K4053359	2015091506	72.39225	-156.59671	1010.0	-0.2	93	57	10.4	1.52	36.6	22553	1:23:42	10	Se
RS057	K4123673	2015091512	72.32993	-156.68658	1012.1	-0.7	88	58	10.7	2.00	47.9	20808	1:23:12	-	-
RS058	K4124162	2015091518	72.06651	-157.22505	1013.3	-1.4	84	61	9.8	3.86	43.8	21377	1:23:23	7	Se
RS059	K4123434	2015091600	72.00685	-156.91801	1013.8	-1.5	80	69	7.1	4.29	53.9	20032	1:07:48	9	Se
RS060a	L2210007	2015091606	72.34056	-156.18341	1015.1	-1.7	86	46	5.4	1.30	38.0	22298	1:09:42	10	Se
RS060b	K4124176	2015091606	72.34040	-156.18300	1015.1	-1.7	86	46	5.4	1.30	38.3	22234	1:09:24	10	Se
RS061	K4123244	2015091612	72.33708	-155.38593	1014.9	-2.8	87	26	3.8	1.45	60.0	19303	1:20:36	-	-
RS062	K4053376	2015091618	72.33080	-155.36433	1015.3	-3.8	89	4	3.9	1.34	50.0	20468	1:16:50	10	Se
RS063	K4053364	2015091700	72.34090	-155.38721	1013.7	-3.6	86	34	4.2	1.18	44.3	21255	1:24:08	10	Se
RS064	K4123668	2015091706	72.35712	-155.31348	1012.5	-4.0	88	84	3.0	0.79	42.3	21542	1:32:02	10	Se
RS065	K4033286	2015091712	72.34344	-155.40411	1010.6	-3.9	90	52	2.6	0.76	48.7	20605	1:28:03	-	-
RS066	K4123674	2015091718	72.35168	-155.36101	1009.7	-3.6	91	325	3.3	0.84	47.5	20765	1:22:26	10	Se, St
RS067	K4124467	2015091800	72.34126	-155.42993	1008.6	-3.5	85	329	1.9	1.08	41.9	21578	1:27:36	9	Se
RS068	K4124159	2015091806	72.36079	-155.42982	1008.1	-2.4	85	10	2.7	1.13	43.9	21257	1:27:18	9	Se, Ac, Ci
RS069	K4123669	2015091812	72.30534	-155.19460	1007.7	-1.9	85	13	10.8	0.91	47.3	20752	1:24:05	-	-
RS070	K4124155	2015091818	72.49960	-155.06557	1010.0	-2.9	77	42	8.5	0.66	50.2	20377	1:22:58	10	Se
RS071	K4123658	2015091900	72.48167	-155.42328	1010.8	-3.5	74	34	7.9	0.65	51.1	20250	1:19:32	10	Se
RS072	K4123254	2015091906	72.48833	-155.42570	1011.5	-2.9	84	31	3.7	0.57	32.0	23272	1:39:00	8	Se
RS073	K4123660	2015091912	72.26995	-156.38004	1012.5	-2.5	67	21	5.0	0.85	44.6	21117	1:29:15	-	-
RS074	K4123675	2015091918	72.44684	-156.17760	1014.2	-3.9	77	358	5.3	0.65	96.7	16072	1:03:49	10	Se
RS075	K4273309	2015092000	72.35831	-155.95006	1015.9	-3.5	73	20	4.1	0.90	32.8	23111	1:27:53	10	Se
RS076	K4273462	2015092006	72.29385	-155.94441	1017.5	-3.9	67	195	0.4	0.69	52.3	20098	1:17:19	10	Se
RS077	K4373013	2015092012	72.28254	-155.98717	1019.2	-4.1	69	275	1.4	0.66	74.4	17805	1:12:12	-	-
RS078	K4273465	2015092018	72.29602	-156.01253	1020.5	-3.9	73	314	2.2	0.30	41.3	21632	1:29:56	5	Se, St
RS079	K4273466	2015092100	72.27573	-155.95757	1021.6	-3.7	76	91	1.4	1.72	37.3	22282	1:30:06	10	Se, St
RS080	K4273467	2015092106	72.30491	-156.06796	1022.4	-3.5	74	111	4.5	0.46	39.5	21913	1:30:15	10	Se
RS081	K4273480	2015092112	72.27930	-155.96896	1023.5	-4.2	74	168	1.1	1.86	45.3	21036	1:23:42	-	-
RS082	K4053366	2015092118	72.29007	-156.02757	1023.9	-4.5	82	90	1.9	0.19	45.4	21011	1:21:50	5	Se, St, Ci
RS083	K4273310	2015092200	72.27694	-155.99681	1024.5	-4.2	91	172	1.2	0.23	35.3	22632	1:28:31	5	St, Se, Ci
RS084	K4373034	2015092206	71.99881	-154.70027	1024.7	-3.5	80	135	0.3	0.09	34.8	22724	1:34:39	10	Se
RS085	K4373015	2015092212	72.18603	-153.55905	1024.7	-4.0	89	223	0.9	-0.70	48.1	20639	1:13:25	-	-
RS086	K4373010	2015092218	71.83186	-153.81688	1023.9	-3.5	94	134	5.3	0.47	50.3	20355	1:22:24	10	St, Se, Ac
RS087	K4373028	2015092300	72.15800	-155.42116	1022.4	-1.6	75	219	8.8	0.61	40.4	21769	1:23:32	6	Se, St, Ci
RS088	K4273460	2015092306	72.32267	-155.71416	1022.2	-1.9	71	222	6.3	-0.19	35.2	22653	1:32:24	10	Se, As
RS089	K4363120	2015092312	72.26196	-155.99211	1022.1	-2.0	70	194	4.7	0.26	37.9	22183	1:24:42	-	-
RS090	K4363124	2015092318	72.27229	-156.42343	1020.2	-2.5	76	165	10.1	0.41	71.0	18152	1:08:18	10	Se, St, Cu
RS091	K4273458	2015092400	72.16930	-155.77740	1016.7	-1.4	70	158	13.9	0.38	41.8	21563	1:29:23	9	Se
RS092	K4373036	2015092406	72.14983	-156.51312	1010.9	-2.2	81	155	13.1	0.68	38.8	22020	1:25:40	10	Se,

RS093	K4363119	2015092412	72.33105	-158.17543	1002.2	0.0	80	159	17.0	1.97	58.4	19394	1:15:19	-	-	As
RS094	K4273459	2015092418	72.78197	-159.10275	995.1	0.9	96	163	11.8	1.48	62.0	18991	1:13:56	10	St	St
RS095a	L2210008	2015092500	73.20937	-157.80121	993.2	0.7	95	170	9.8	-0.48	23.2	25309	1:22:26	10	St	St
RS095b	K4373020	2015092500	73.20840	-157.80600	993.2	0.7	95	170	9.8	-0.48	23.6	25164	1:22:24	10	St	St
RS096	K4373012	2015092506	72.92014	-158.72156	990.9	1.3	97	176	8.8	1.20	31.2	23389	1:34:54	10	St	St
RS097	K4273463	2015092512	72.79971	-161.40073	988.2	1.1	99	130	4.5	1.13	34.5	22741	1:30:52	-	-	St
RS098	K4363118	2015092518	73.24041	-161.08815	989.1	1.0	100	349	0.7	1.52	37.5	22207	1:23:51	10	St	St
RS099	K4273469	2015092600	73.11540	-162.45679	993.4	-1.0	89	339	12.7	1.02	36.2	22437	1:27:31	10	St	St
RS100	K4273451	2015092606	73.05756	-164.62415	1000.6	-2.5	83	338	13.6	0.96	51.3	20194	1:32:47	10	Sc	Sc
RS101	K4273475	2015092612	73.22135	-161.41240	1002.2	-3.1	88	339	12.4	1.55	36.1	22428	1:29:04	-	-	St
RS102	K4363126	2015092618	73.30497	-160.77823	1005.2	-3.2	90	336	10.6	0.17	41.7	21515	1:20:30	10	St	St
RS103	K4273453	2015092700	73.32259	-160.76489	1008.4	-2.4	76	323	7.3	-0.23	37.9	22106	1:30:03	7	St, Ci	St, Ci
RS104	K4373025	2015092706	72.97946	-161.19940	1010.0	-1.2	80	232	0.4	1.25	41.1	21584	1:25:16	6	St, Ac, As	St, Ac, As
RS105	K4273461	2015092712	73.37345	-162.35704	1009.1	-0.1	85	215	7.0	1.64	31.8	23220	1:35:28	-	-	St
RS106	K4273474	2015092718	73.48804	-162.23766	1006.6	0.0	84	196	9.7	1.57	37.6	22128	1:24:26	10	St, Sc	St, Sc
RS107	K4273450	2015092800	73.47340	-160.13574	1004.0	-1.1	85	195	5.1	-0.07	47.4	20659	1:09:33	10	St, Sc	St, Sc
RS108	K4273464	2015092806	73.50656	-162.14961	998.5	-0.8	71	157	9.3	1.32	74.8	17697	1:15:39	10	Sc	Sc
RS109	K4363122	2015092812	73.56889	-165.93736	992.7	-0.5	81	139	8.2	0.94	35.4	22505	1:32:34	-	-	St
RS110a	L2210023	2015092818	74.36890	-166.56891	987.8	-1.4	92	164	8.6	-0.79	31.2	23291	1:14:56	10	St	St
RS110b	K4273471	2015092818	74.40010	-166.59700	987.8	-1.4	92	164	8.6	-0.79	31.6	23198	1:14:54	10	St	St
RS111a	L2210015	2015092900	74.46580	-168.18427	982.0	-0.9	70	167	11.2	-0.42	33.7	22811	1:12:15	9	St, Sc	St, Sc
RS111b	K4363321	2015092900	74.46940	-168.24400	982.0	-0.9	70	167	11.2	-0.42	34.1	22700	1:12:10	9	St, Sc	St, Sc
RS112a	L2210202	2015092906	74.00189	-168.75548	979.9	-2.3	80	210	9.9	1.32	57.9	19338	1:01:24	7	Cb, Cu, Se	Cb, Cu, Se
RS112b	K4213822	2015092906	74.00200	-168.75500	979.9	-2.3	80	210	9.9	1.32	58.5	19248	1:01:22	7	Cb, Cu, Se	Cb, Cu, Se
RS113	K4373187	2015092912	73.36040	-168.74582	979.5	-1.2	80	259	11.4	0.46	36.9	22201	1:26:20	-	-	St
RS114	K4213817	2015092918	72.49651	-168.79433	983.0	-0.7	68	270	13.8	0.97	44.8	20978	1:24:49	10	St, Sc	St, Sc
RS115	K4363340	2015093000	71.99802	-168.74080	987.0	-0.9	74	303	9.5	2.30	49.4	20366	1:15:34	8	Sc, St	Sc, St
RS116	K4363350	2015093006	71.15580	-168.75365	990.0	-0.3	69	280	10.4	3.36	37.0	22239	1:29:56	6	Sc, Cu, Ci	Sc, Cu, Ci
RS117a	L2210009	2015093012	70.37884	-168.75529	993.2	-2.1	89	282	7.0	3.73	53.6	19897	1:04:17	-	-	St
RS117b	K4363368	2015093012	70.37300	-168.75500	993.2	-2.1	89	282	7.0	3.73	54.2	19804	1:04:14	-	-	St
RS118	K4363372	2015093018	69.20287	-168.79466	1000.0	1.3	58	286	12.1	5.03	32.6	23110	1:34:12	5	Ns, Sc, St	Ns, Sc, St
RS119a	L2130512	2015100100	68.06068	-168.82922	1008.6	1.8	69	296	7.1	4.03	35.6	22613	1:12:56	6	Ns, Cu, Se	Ns, Cu, Se
RS119b	K4273022	2015100100	68.04870	-168.81600	1008.6	1.8	69	296	7.1	4.03	36.5	22448	1:12:54	6	Ns, Cu, Se	Ns, Cu, Se
RS120	K4213826	2015100106	68.54048	-168.74947	1013.2	0.4	79	277	12.7	4.70	43.1	21374	1:30:05	7	Ns, Cu, Se	Ns, Cu, Se
RS121	K4363383	2015100112	68.69044	-168.79134	1017.7	1.7	57	265	2.8	4.47	37.9	22250	1:30:42	-	-	St
RS122	K4363384	2015100118	68.04620	-168.83580	1017.0	3.0	66	132	8.2	3.96	36.9	22464	1:38:20	3	Cu, Se	Cu, Se
RS123	K4363381	2015100200	68.03451	-168.83813	1012.2	3.3	80	127	13.1	3.94	51.4	20368	1:17:37	10	St, Sc	St, Sc
RS124	K4273179	2015100206	68.03481	-168.83112	1004.2	1.9	95	111	15.5	3.96	51.3	20410	1:22:47	10	St	St
RS125	K4363363	2015100212	68.04427	-168.79335	1000.9	3.4	95	110	11.1	4.03	47.0	20989	1:30:14	-	-	St
RS126	K4363364	2015100218	68.06681	-168.88242	1002.2	4.8	96	142	8.9	4.05	68.3	18571	1:09:14	10	St, Sc	St, Sc
RS127	K4363361	2015100300	68.06598	-168.84926	1005.9	4.9	97	111	9.0	4.17	37.6	22440	1:41:10	10	St	St
RS128	K4363351	2015100306	67.73640	-168.86101	1007.1	4.8	98	110	10.6	4.74	45.7	21207	1:50:18	10	St	St
RS129	K4363355	2015100312	66.84723	-168.73058	1007.6	4.7	100	160	6.1	3.62	36.2	22756	1:33:56	-	-	St
RS130	K4213819	2015100318	66.01196	-168.74290	1007.5	5.0	100	118	6.1	3.82	47.7	20989	1:34:58	10	St	St
RS131	K4363375	2015100400	65.04225	-168.65459	1008.5	4.6	100	234	5.4	4.71	38.4	22432	1:34:48	10	St	St
RS132	K4363378	2015100406	63.90931	-168.65459	1011.8	5.6	100	209	1.4	5.75	34.5	23119	1:37:23	10	St	St
RS133	K4363345	2015100412	62.74623	-167.36163	1015.1	3.6	94	239	9.6	5.67	39.4	22262	1:27:14	-	-	St
RS134	K4263217	2015100418	61.79443	-167.37611	1014.3	6.7	96	163	10.9	7.52	39.3	22294	1:27:05	10	St	St

RS135a	L2210018	2015100500	60.74169	-167.77675	1011.4	8.1	100	186	14.3	8.55	60.4	19498	1:08:09	10	St
RS135b	K4214847	2015100500	60.76970	-167.76700	1011.4	8.1	100	186	14.3	8.55	60.7	19476	1:08:16	10	St
RS136	K4273198	2015100506	59.67782	-167.86555	1009.3	7.9	99	158	9.9	7.28	84.3	17311	1:19:00	10	St
RS137	K4273177	2015101100	53.91833	-174.07140	1000.8	6.2	64	313	14.4	8.82	38.7	22134	1:43:22	10	Sc, Ns
RS138	K4213827	2015101112	53.78894	-177.34201	1002.8	7.1	69	307	13.1	9.05	35.7	22630	1:44:12	-	-
RS139a	L2210024	2015101200	53.63932	178.82361	1006.8	6.3	90	10	3.8	9.21	24.5	25051	1:20:45	10	St
RS139b	K4264084	2015101200	53.64030	178.84100	1006.8	6.3	90	10	3.8	9.21	25.8	24717	1:20:20	10	St
RS140	K4363348	2015101212	53.43379	174.20346	1000.4	9.4	95	177	5.7	9.61	38.0	22300	1:39:17	-	-
RS141	K4363357	2015101300	52.22132	171.13123	988.7	10.2	85	239	10.6	9.68	34.2	22999	1:31:40	10	Ns Sc
RS142	K4363360	2015101312	50.62152	169.90807	997.7	10.2	87	296	8.0	10.33	37.5	22464	1:36:13	-	-
RS143	K4363338	2015101400	48.87679	168.62045	1008.8	10.1	68	306	4.8	10.57	30.9	23678	1:41:01	3	Sc, Ac
RS144	K4363382	2015101412	46.98469	167.31703	1000.1	12.6	98	234	10.5	12.12	38.2	22343	1:31:53	-	-
RS145	K4363346	2015101500	45.80017	166.49316	1005.3	11.9	71	258	10.0	11.64	39.7	22091	1:25:37	2	Cu Sc
RS146	K4363346	2015101512	45.84405	165.71284	1003.0	11.0	72	258	14.8	11.72	39.7	22082	1:29:37	-	-
RS147	K4363362	2015101600	45.29737	163.93716	1004.0	10.0	68	269	16.1	11.60	42.3	21641	1:27:07	7	Ns Cu
RS148	K4363367	2015101612	44.43087	162.19612	1006.4	9.7	64	280	15.4	13.27	35.1	22855	1:32:06	-	-
RS149	K3943947	2015101700	43.80652	160.00404	1010.2	10.0	58	287	11.7	13.64	34.3	23013	1:27:59	9	Ac, Cu
RS150	K4124462	2015101712	42.83839	157.67244	1015.4	9.9	60	341	11.2	14.27	33.0	23256	1:36:17	-	-
RS151a	L2130511	2015101800	41.78959	154.88379	1019.8	12.0	64	177	2.9	15.02	22.2	25928	1:22:56	0	-
RS151b	K4133205	2015101800	41.78870	154.88100	1019.8	12.0	64	177	2.9	15.02	22.8	25576	1:22:56	0	-
RS152	K4124157	2015101812	40.82873	152.00699	1014.8	13.6	82	158	8.0	11.83	42.6	21659	1:29:18	-	-
RS153	K4033243	2015101900	40.18668	149.28046	1012.4	16.0	87	285	5.7	18.00	28.6	24180	1:43:32	1	Cs
RS154	K4123652	2015101912	40.26485	146.26045	1016.5	12.2	56	79	3.8	17.10	62.4	19238	1:22:17	-	-
RS155	K4124454	2015102000	40.37755	143.17694	1009.4	14.3	82	241	7.0	14.60	30.9	23670	1:35:28	1	Cu

Table 2.1-2: Statistics of differences between RS41 and RS92 (RS41 minus RS92). Differences were calculated at the same observation time or altitude.

	Time		Altitude	
	Mean difference (bias)	Standard deviation	Mean difference (bias)	Standard deviation
Pressure (hPa)	-0.30	0.47	+0.13	0.25
Temperature (°C)	-0.03	0.13	+0.02	0.26
Relative humidity (%RH)	+2.58	3.91	+1.53	3.56
Wind speed (m/s)	-0.00	0.13	+0.02	0.60

2.2. C-band weather radar

(1) Personnel

Kazuhiro Oshima	JAMSTEC	- PI
Yoshimi Kawai	JAMSTEC	
Masatake Hori	JAMSTEC	- not on board
Jun Inoue	JAMSTEC / NIPR	- not on board
Shinya Okumura	GODI	
Wataru Tokunaga	GODI	
Koichi Inagaki	GODI	
Yutaro Murakami	GODI	
Soichiro Sueyoshi	GODI	
Masanori Murakami	MIRAI Crew	

(2) Objectives

Low level clouds over the Arctic Ocean which usually dominate during summer have a key role for sea/ice surface heat budget. In addition, cyclones which modify the sea-ice distributions are substantially important to understand the air-ice-sea interaction. To capture the broad cloud-precipitation systems and their temporal and spatial evolution over the Arctic Ocean, three dimensional radar echo structure and wind fields of rain/snow clouds was obtained by C-band Doppler radar observation. At the same time, scans are performed to evaluate the performance of the radar, and to develop the better strategy of the radar observation.

(3) Parameters

C-band Doppler radar observed three dimensional radar echo structure and wind fields of rain/snow cloud.

(4) Instruments and methods

The C-band weather radar on board R/V Mirai is used. The basic specification of the radar is as follows:

Frequency:	5370 MHz (C-band)
Polarimetry:	Horizontal and vertical (simultaneously transmitted and received)
Transmitter:	Solid-state transmitter
Pulse Configuration:	Using pulse-compression
Output Power:	6 kW (H) + 6 kW (V)
Antenna Diameter:	4 meter
Beam Width:	1.0 degrees
Laser Gyro:	PHINS (Ixsea S.A.S.)

The antenna is controlled to point the commanded ground-relative direction, by controlling the azimuth and elevation to cancel the ship attitude (roll, pitch and yaw) detected by the laser gyro. The Doppler velocity is also corrected by subtracting the ship motion in beam direction.

As the maintenance, internal parameters of the radar are checked and calibrated at the beginning and the end of the cruise. Meanwhile, the following parameters are checked daily; (1) frequency, (2) mean output power, (3) pulse width, and (4) PRF (pulse repetition frequency).

During the cruise, the radar was operated typically by repeating a volume scan with 17 PPIs (Plan Position Indicators) every 6-minute. A dual PRF mode with the maximum range of typically 100 km is used for the volume scan. A surveillance PPI scan is performed every 30 minutes in a single PRF mode with the maximum range of 300 km. RHI (Range Height Indicator) scans are also operated whenever detailed vertical structures are necessary in certain azimuth directions. Over the Arctic Ocean (poleward from the Bering Strait), the scan strategy is kept same, as in Table 2.2-1, to provide the same data quality to highlight the temporal variation of the precipitating systems. On the other hand, some other scan strategies were adopted out of Arctic Ocean to examine the performance of the radar.

Observation periods of Leg 1 and Leg 2 are as follows:

Leg1: 02:48UTC 27 Aug. 2015 – 19:18UTC 06 Oct. 2015

Leg2: 22:24UTC 09 Oct. 2015 – 12:00UTC 19 Oct. 2015

Table 2.2-1: Parameters for scan strategy in the Arctic Ocean.

	Surveillance PPI	Volume Scan						RHI
Repeated Cycle (min.)	30	6						6
Pulse Width (long / short, in microsec)	200 / 2	64 / 1	32 / 1		32 / 1		32 / 1	
Scan Speed (deg/sec)	36	18	24		36		9 (in el.)	
PRF(s) (Hz)	400	dual PRF (ray alternative)						1250
		667	833	938	1250	1333	2000	
Pulses / Ray	8	26	33	27	34	37	55	32
Ray Spacing (deg.)	0.7	0.7		0.7		1.0		0.23
Azimuth	Full Circle						Optional	
Bin Spacing (m)	150							
Max. Range (km)	300	150	100		60		100	

Elevation Angle(s) (deg.)	0.5	0.5	1.0, 1.7, 2.4, 3.1, 3.8, 4.6, 5.5, 6.5, 7.6, 8.9	10.4, 12.0, 13.8, 16.0, 18.3, 21.0	0.0 to 45.0 (to 70.0 when necessary)
---------------------------	-----	-----	--	--	---

(5) Preliminary results

Figure 2.2-1, 2.2-2, 2.2-3, 2.2-4 and 2.2-5 show the PPI image, NOAA satellite image, and weather condition, i.e. SLP, wind and SAT fields, from JMA GPV for precipitating events. During the cruise, especially in the latter half of the Arctic observation, several cyclones passed near the R/V MIRAI. The C-band weather radar captured cloud systems accompanied with the low pressure systems. A small cyclone was observed around Barrow during September 13-14 (Figure 2.2-1). The fronts associated with the low pressure systems were observed on September 24 (Figure 2.2-2), 28 (Figure 2.2-3) and October 2 (Figure 2.2-5). Moreover, the cyclone center was captured by the radar on September 29 (Figure 2.2-4). The further detailed analyses will be performed after the cruise.

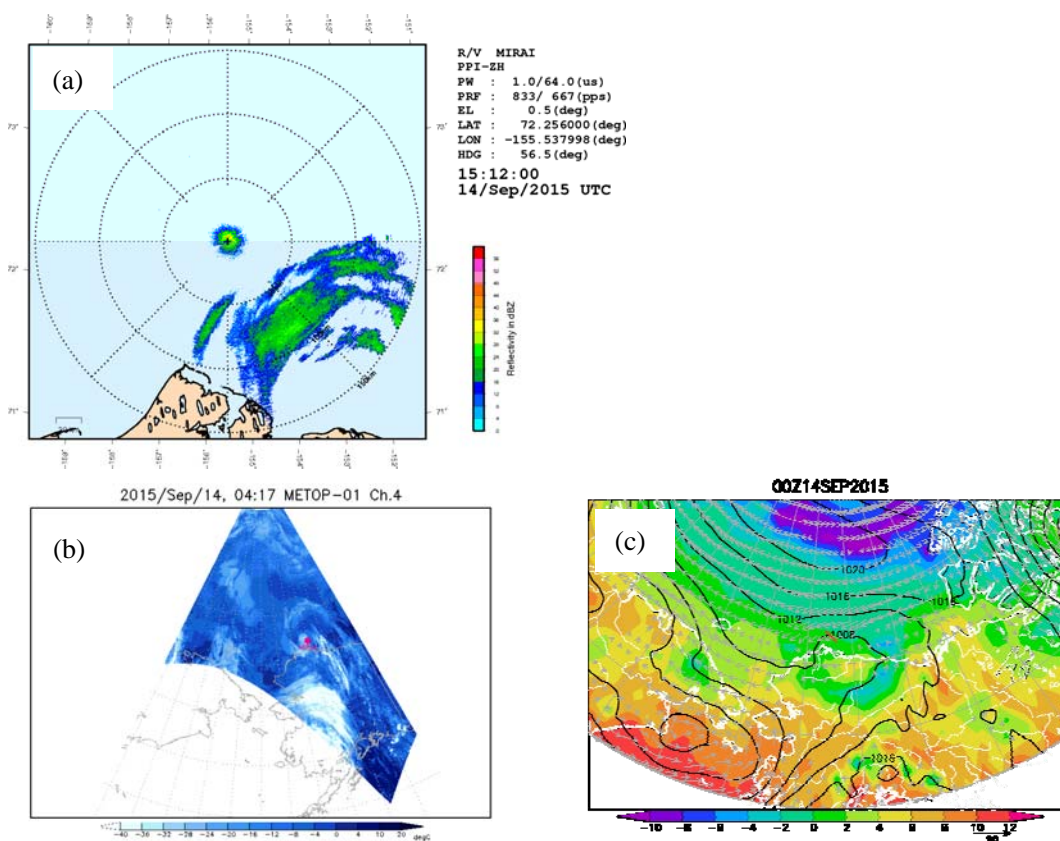

Figure 2.2-1: (a) PPI image obtained by the first volume scan at elevation angle of 0.5 degree, (b) NOAA satellite image, (c) sea level pressure (SLP, contour), wind (vector) and surface air temperature (SAT, shade) fields from JMA GPV on September 14.

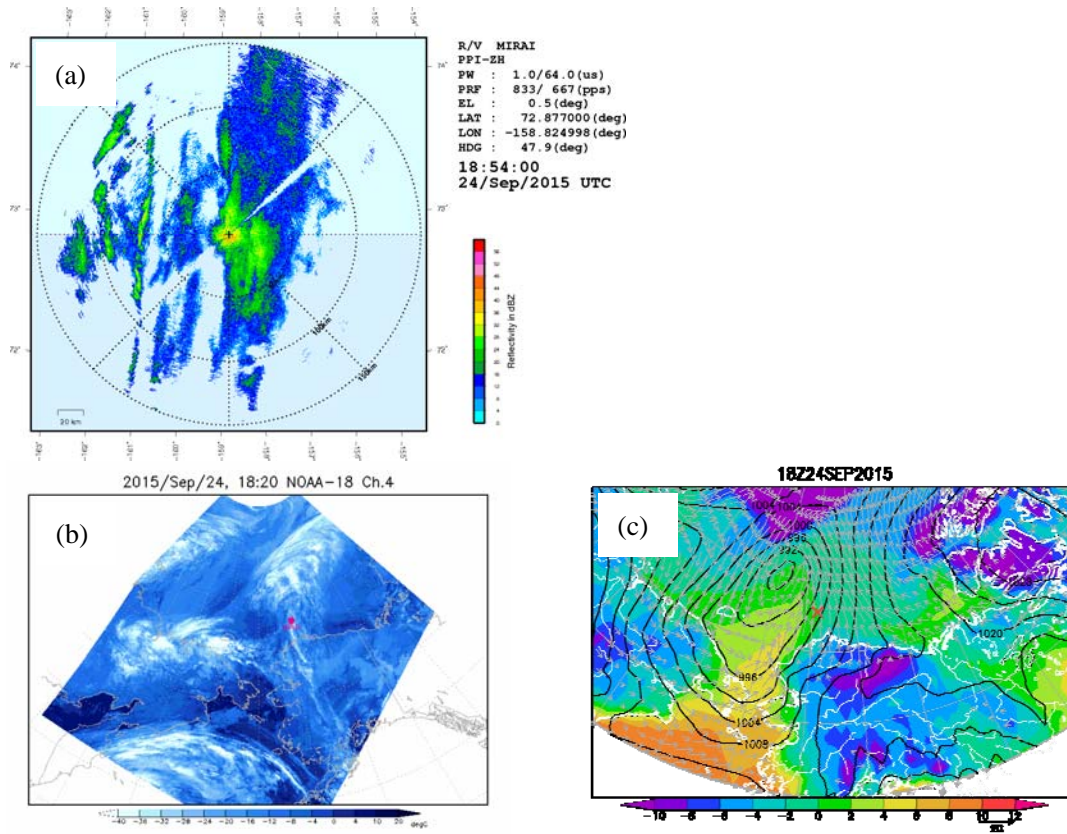

Figure 2.2-2: Same as in Figure 2.2-1, but for September 24.

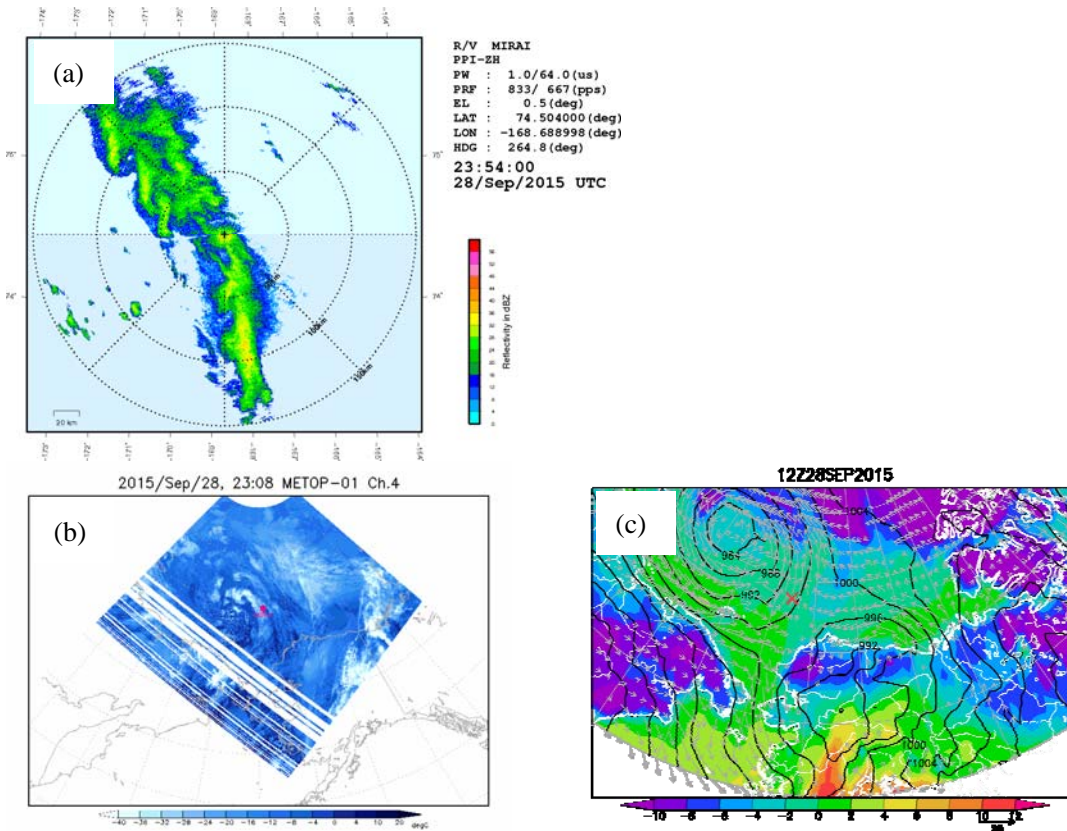

Figure 2.2-3: Same as in Figure 2.2-1, but for September 28.

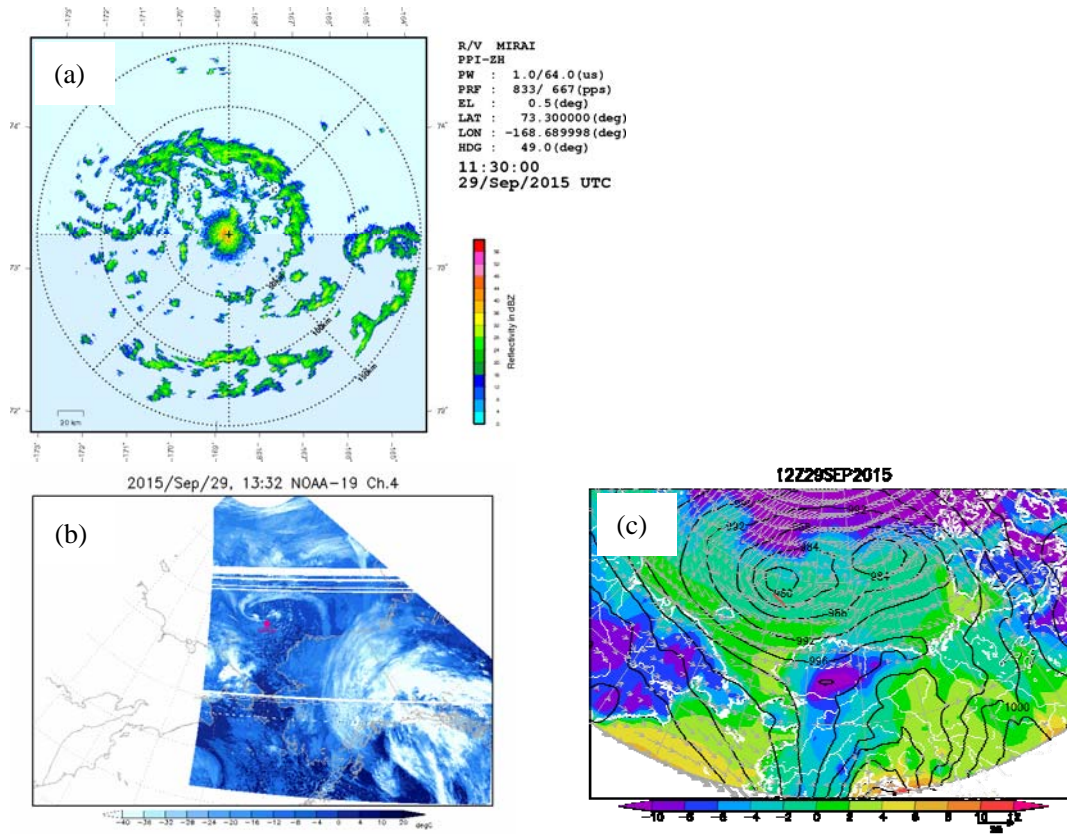

Figure 2.2-4: Same as in Figure 2.2-1, but for September 29.

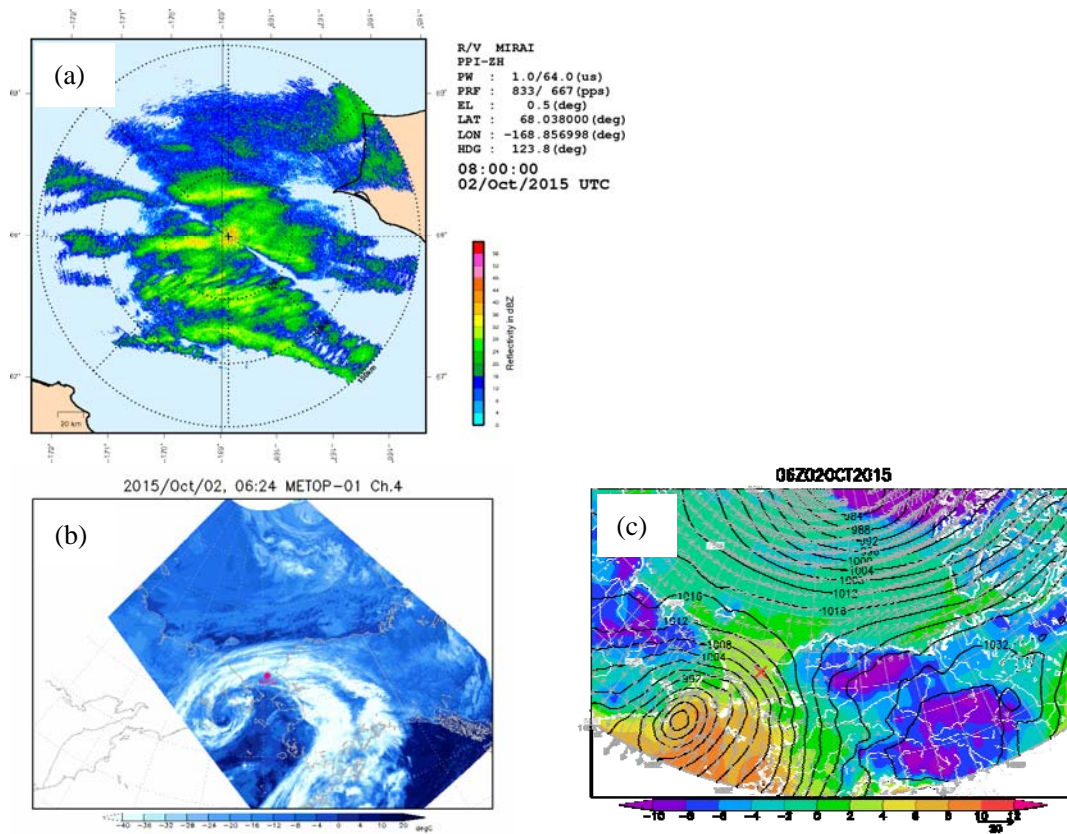

Figure 2.2-5: Same as in Figure 2.2-1, but for October 2.

(6) Data archives

These data obtained in this cruise will be submitted to the Data Management Group of JAMSTEC, and will be opened to the public via “Data Research System for Whole Cruise Information in JAMSTEC (DARWIN)” in JAMSTEC web site.
<<http://www.godac.jamstec.go.jp/darwin/e>>

2.3. Surface meteorological observations

(1) Personnel

Shigeto Nishino	JAMSTEC: PI	Leg1
Shinya Okumura	Global Ocean Development Inc. (GODI)	Leg1
Wataru Tokunaga	GODI	Leg1
Koichi Inagaki	GODI	Leg1
Souichiro Sueyoshi	GODI	Leg2
Yutaro Murakami	GODI	Leg1, Leg2
Masanori Murakami	MIRAI Crew	Leg1, Leg2

(2) Objectives

Surface meteorological parameters are observed as a basic dataset of the meteorology. These parameters provide the temporal variation of the meteorological condition surrounding the ship.

(3) Instruments and methods

Surface meteorological parameters were observed during the this cruise. In this cruise, we used two systems for the observation.

i. MIRAI Surface Meteorological observation (SMet) system

Instruments of SMet system are listed in Table 2.3-1 and measured parameters are listed in Table 2.3-2. Data were collected and processed by KOAC-7800 weather data processor made by Koshin-Denki, Japan. The data set consists of 6-second averaged data.

ii. Shipboard Oceanographic and Atmospheric Radiation (SOAR) measurement system

SOAR system designed by BNL (Brookhaven National Laboratory, USA) consists of major five parts.

- a) Portable Radiation Package (PRP) designed by BNL – short and long wave downward radiation.
- b) Analog meteorological data sampling with CR1000 logger manufactured by Campbell Inc. Canada – wind pressure, and rainfall (by a capacitive rain gauge) measurement.
- c) Digital meteorological data sampling from individual sensors - air temperature, relative humidity and rainfall (by optical rain gauge (ORG)) measurement.
- d) Photosynthetically Available Radiation (PAR) sensor manufactured by Biospherical Instruments Inc. (USA) - PAR measurement.
- e) Scientific Computer System (SCS) developed by NOAA (National Oceanic and Atmospheric Administration, USA) – centralized data acquisition and logging of all data sets.

SCS recorded PRP, air temperature and relative humidity, CR1000 and ORG data. SCS composed Event data (JamMet) from these data and ship's navigation data every 6 seconds. Instruments and their locations are listed in Table 2.3-3 and measured parameters are listed in Table 2.3-4.

For the quality control as post processing, we checked the following sensors, before and after the cruise.

- i. Young Rain gauge (SMet and SOAR)
Inspect of the linearity of output value from the rain gauge sensor to change Input value by adding fixed quantity of test water.
- ii. Barometer (SMet and SOAR)
Comparison with the portable barometer value, PTB220, VAISALA
- iii. Thermometer (air temperature and relative humidity) (SMet and SOAR)
Comparison with the portable thermometer value, HM70, VAISALA

(4) Preliminary results

Figure. 2.3-1 shows the time series of the following parameters;

Wind (SOAR)
Air temperature (SMet)
Relative humidity (SMet)
Precipitation (SOAR, ORG)
Short/long wave radiation (SOAR)
Pressure (SMet)
Sea surface temperature (SMet)
Significant wave height (SMet)

(5) Data archives

These data obtained in this cruise will be submitted to the Data Management Group of JAMSTEC, and will be opened to the public via “Data Research System for Whole Cruise Information in JAMSTEC (DARWIN)” in JAMSTEC web site.

<<http://www.godac.jamstec.go.jp/darwin/e>>

(6) Remarks (Times in UTC)

- i) The following periods, Sea surface temperature of SMet data was available.
09:29 26 Aug. 2015 - 03:30 05 Sep. 2015
21:29 05 Sep. 2015 - 00:30 06 Oct. 2015
- ii) The following time, increasing of SMet capacitive rain gauge data were invalid due to transmitting for VHF radio.
19:52 07 Sep. 2015
20:19 07 Sep. 2015
22:47 04 Oct. 2015 – 22:59 04 Oct. 2015

- iii) The following time, increasing of SMet capacitive rain gauge data were invalid due to test transmitting for MF/HF radio.
02:39 31 Aug. 2015
21:56 21 Sep. 2015
18:58 05 Oct. 2015
- iv) The following period, portside temperature, dew point temperature and relative humidity data of SMet were not acquisition due to sensor replacement.
02:40 03 Sep. 2015 - 02:50 03 Sep. 2015
- v) The following period, acquisition of JamMet was stopped due to network maintenance.
22:10 08 Sep. 2015 – 22:12 08 Sep. 2015
- vi) The following period, PAR data was invalid due to maintenance.
20:50 07 Sep. 2015 - 20:59 07 Sep. 2015
16:28 09 Sep. 2015 - 16:30 09 Sep. 2015
- vii) The following period, ORG data of JamMet was invalid.
17:28 31 Aug. 2015 - 17:31 31 Aug. 2015
- viii) The following time, Pressure data of JamMet was invalid due to sensor trouble.
17:28 31 Aug. 2015

Table 2.3-1: Instruments and installation locations of SMet system

Sensors	Type	Manufacturer	Location(altitude from surface)
Anemometer	KE-500	Koshin Denki, Japan	foremast (24 m)
Tair/RH	HMP155	Vaisala, Finland	
			with 43408 Gill aspirated radiation shield R.M. Young, USA compass deck (21 m) starboard and port side
Thermometer: SST	RFN2-0	Koshin Denki, Japan	4th deck (-1m, inlet -5m)
Barometer	Model-370	Setra System, USA	captain deck (13 m) weather observation room
Rain gauge	50202	R. M. Young, USA	compass deck (19 m)
Optical rain gauge	ORG-815DS	Osi, USA	compass deck (19 m)
Radiometer (short wave)	MS-802	Eko Seiki, Japan	radar mast (28 m)
Radiometer (long wave)	MS-202	Eko Seiki, Japan	radar mast (28 m)
Wave height meter	WM-2	Tsurumi-seiki, Japan	bow (10 m)

Table 2.3-2: Parameters of MIRAI Surface Meteorological observation system

Parameter	Units	Remarks
1 Latitude	degree	
2 Longitude	degree	
3 Ship's speed	knot	Mirai log, DS-30 Furuno

4 Ship's heading	degree	Mirai Gyro, TOKYO-KEIKI, TG-6000
5 Relative wind speed	m/s	6sec./10min. averaged
6 Relative wind direction	degree	6sec./10min. averaged
7 True wind speed	m/s	6sec./10min. averaged
8 True wind direction	degree	6sec./10min. averaged
9 Barometric pressure	hPa	adjusted to sea surface level 6sec. averaged
10 Air temperature (starboard)	degC	6sec. averaged
11 Air temperature (port side)	degC	6sec. averaged
12 Dewpoint temperature (starboard)	degC	6sec. averaged
13 Dewpoint temperature (port side)	degC	6sec. averaged
14 Relative humidity (starboard)	%	6sec. averaged
15 Relative humidity (port side)	%	6sec. averaged
16 Sea surface temperature	degC	6sec. averaged
17 Rain rate (optical rain gauge)	mm/hr	hourly accumulation
18 Rain rate (capacitive rain gauge)	mm/hr	hourly accumulation
19 Down welling shortwave radiation	W/m ²	6sec. averaged
20 Down welling infra-red radiation	W/m ²	6sec. averaged
21 Significant wave height (bow)	m	hourly
22 Significant wave height (aft)	m	hourly
23 Significant wave period (bow)	second	hourly
24 Significant wave period (aft)	second	hourly

Table 2.3-3: Instruments and installation locations of SOAR system

<u>Sensors (Meteorological)</u>	<u>Type</u>	<u>Manufacturer</u>	<u>Location (altitude from surface)</u>
Anemometer	05106	R.M. Young, USA	foremast (25 m)
Barometer	PTB210	Vaisala, Finland	foremast (23 m)
with 61002 Gill pressure port,		R.M. Young, USA	
Rain gauge	50202	R.M. Young, USA	foremast (24 m)
Tair/RH	HMP155	Vaisala, Finland	foremast (23 m)
with 43408 Gill aspirated radiation shield		R.M. Young, USA	foremast (23 m)
Optical rain gauge	ORG-815DR	Osi, USA	foremast (24 m)
<u>Sensors (PRP)</u>	<u>Type</u>	<u>Manufacturer</u>	<u>Location (altitude from surface)</u>
Radiometer (short wave)	PSP	Epply Labs, USA	foremast (25 m)
Radiometer (long wave)	PIR	Epply Labs, USA	foremast (25 m)
Fast rotating shadowband radiometer		Yankee, USA	foremast (25 m)
<u>Sensor (PAR)</u>	<u>Type</u>	<u>Manufacturer</u>	<u>Location (altitude from surface)</u>
PAR sensor	PUV-51	Biospherical Instruments Inc., USA	Navigation deck (18m)

Table 2.3-4: Parameters of SOAR system (JamMet)

Parameter	Units	Remarks
1 Latitude	degree	
2 Longitude	degree	
3 SOG	knot	
4 COG	degree	
5 Relative wind speed	m/s	
6 Relative wind direction	degree	
7 Barometric pressure	hPa	
8 Air temperature	degC	
9 Relative humidity	%	
10 Rain rate (optical rain gauge)	mm/hr	
11 Precipitation (capacitive rain gauge)	mm	reset at 50 mm
12 Down welling shortwave radiation	W/m ²	
13 Down welling infra-red radiation	W/m ²	
14 Defuse irradiance	W/m ²	
15 PAR	microE/cm ² /sec	

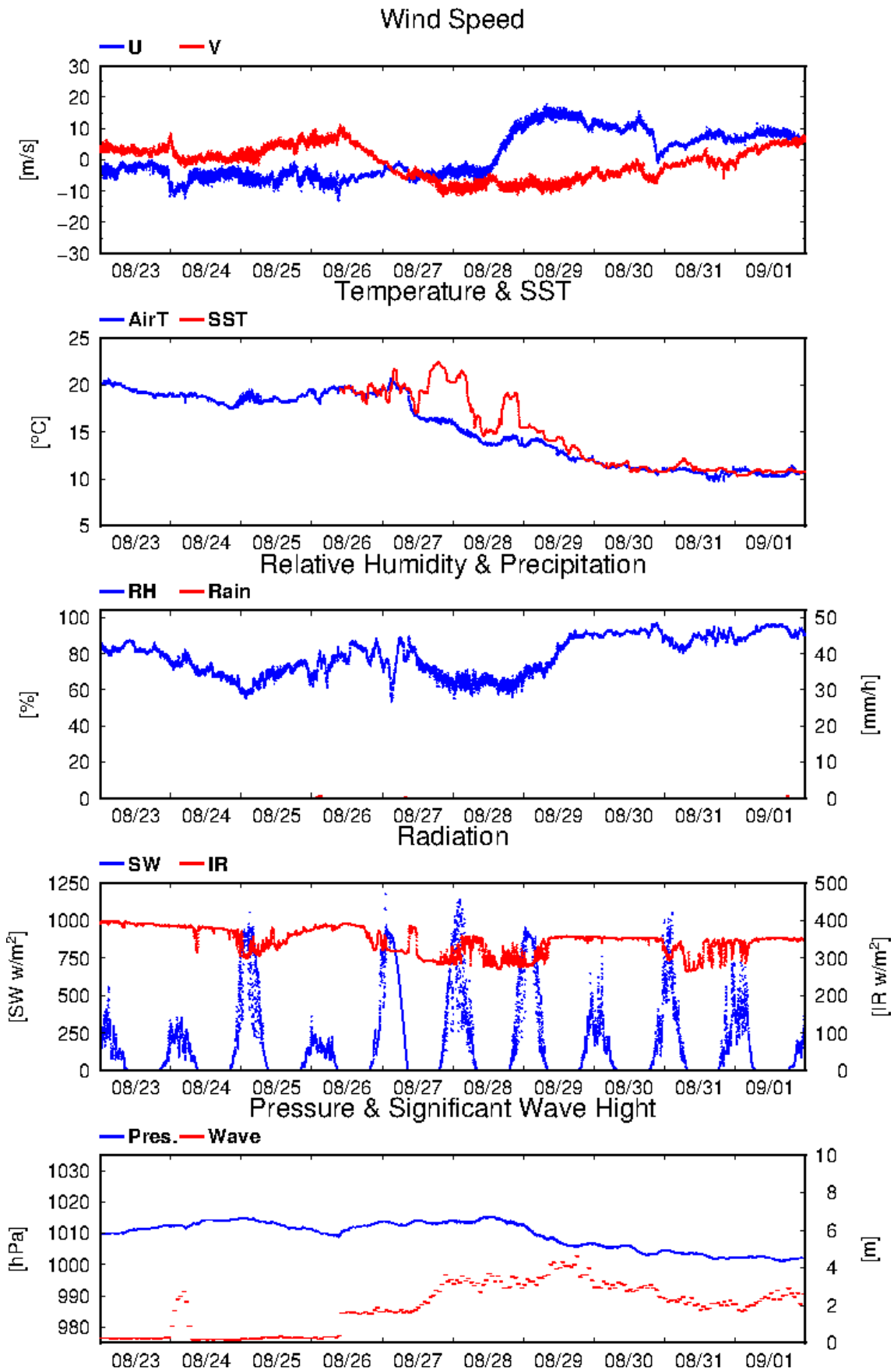

Figure 2.3-1: Time series of surface meteorological parameters during this cruise

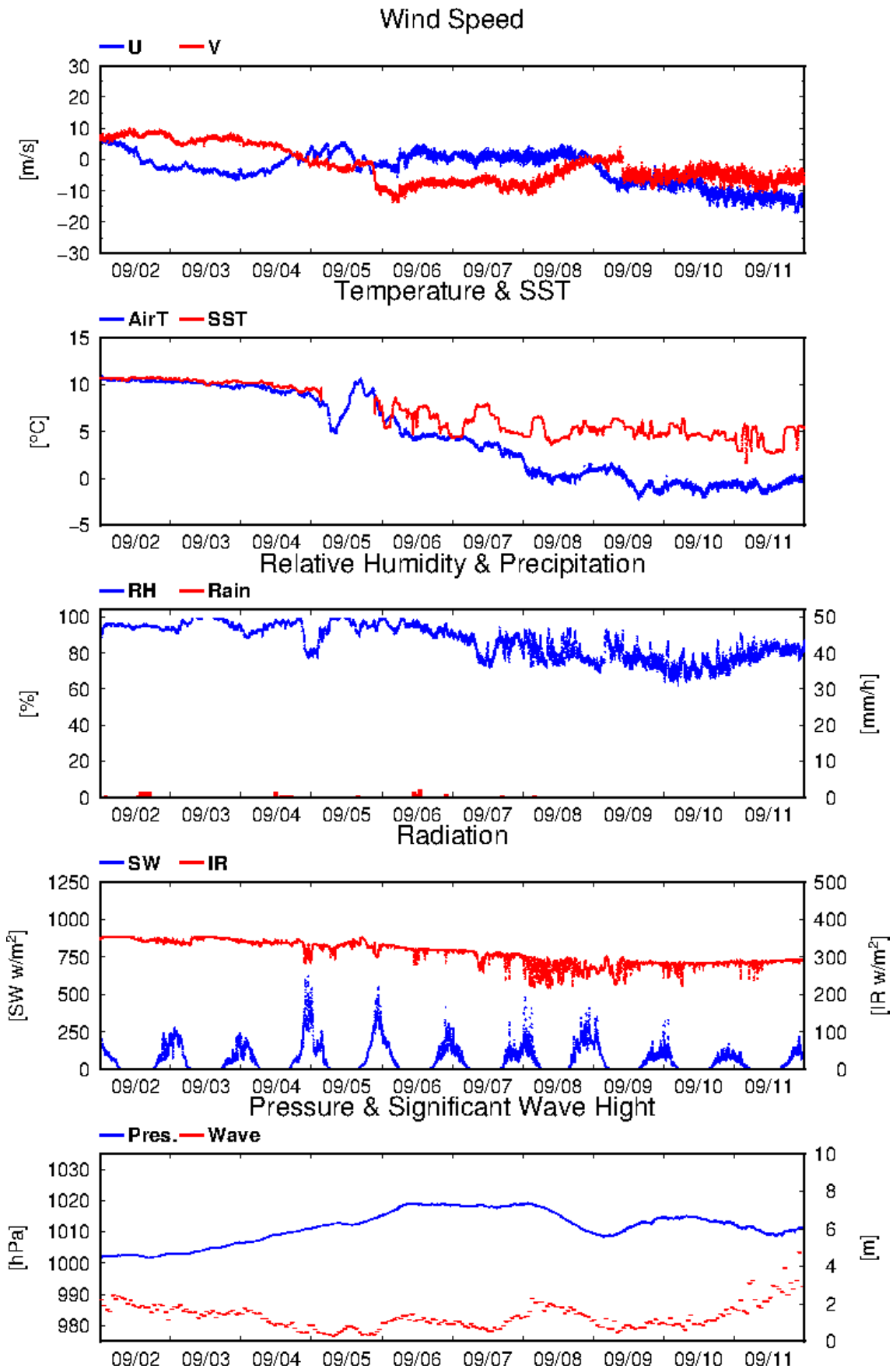

Figure 2.3-1: (Continued)

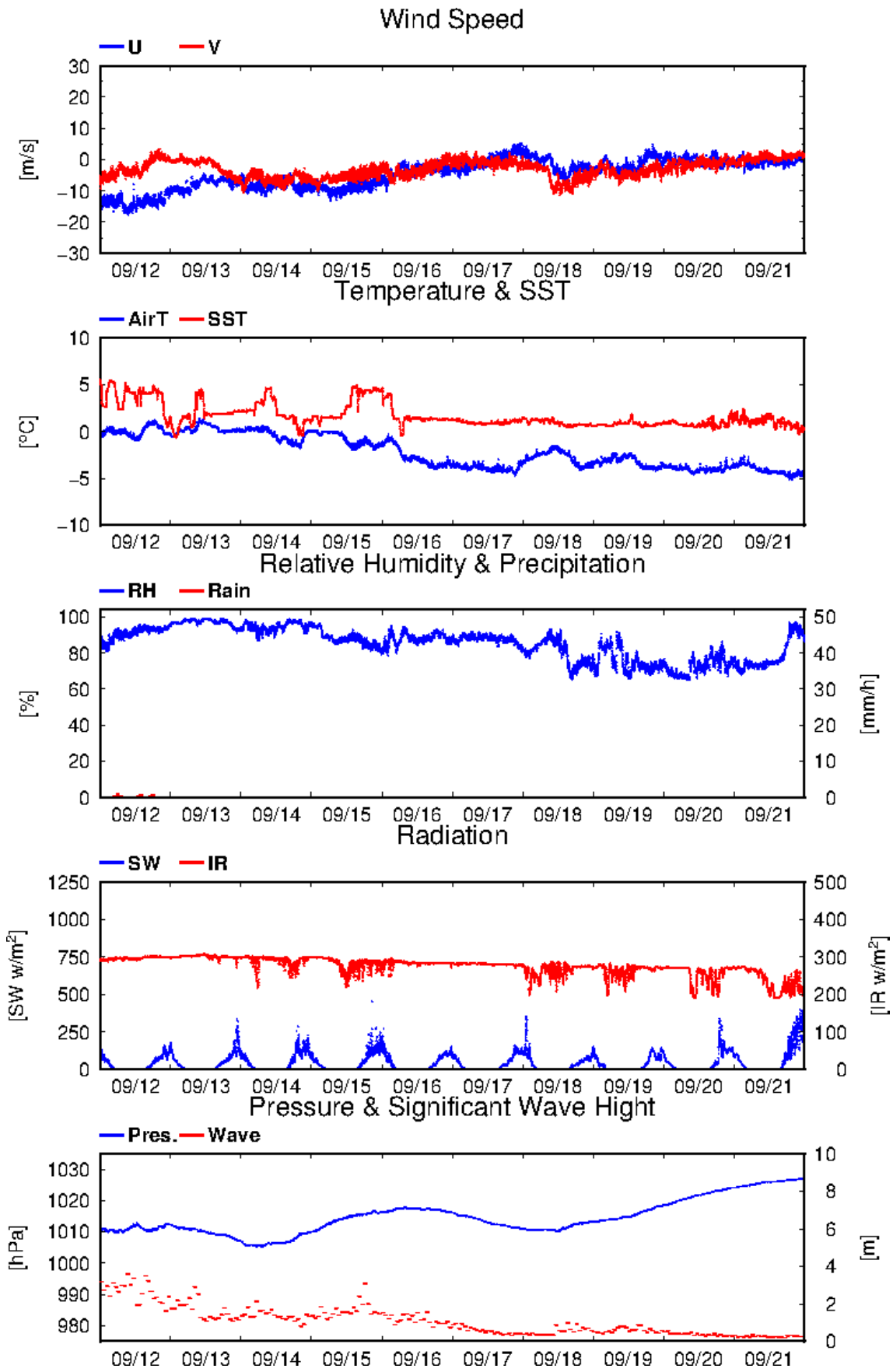

Figure 2.3-1: (Continued)

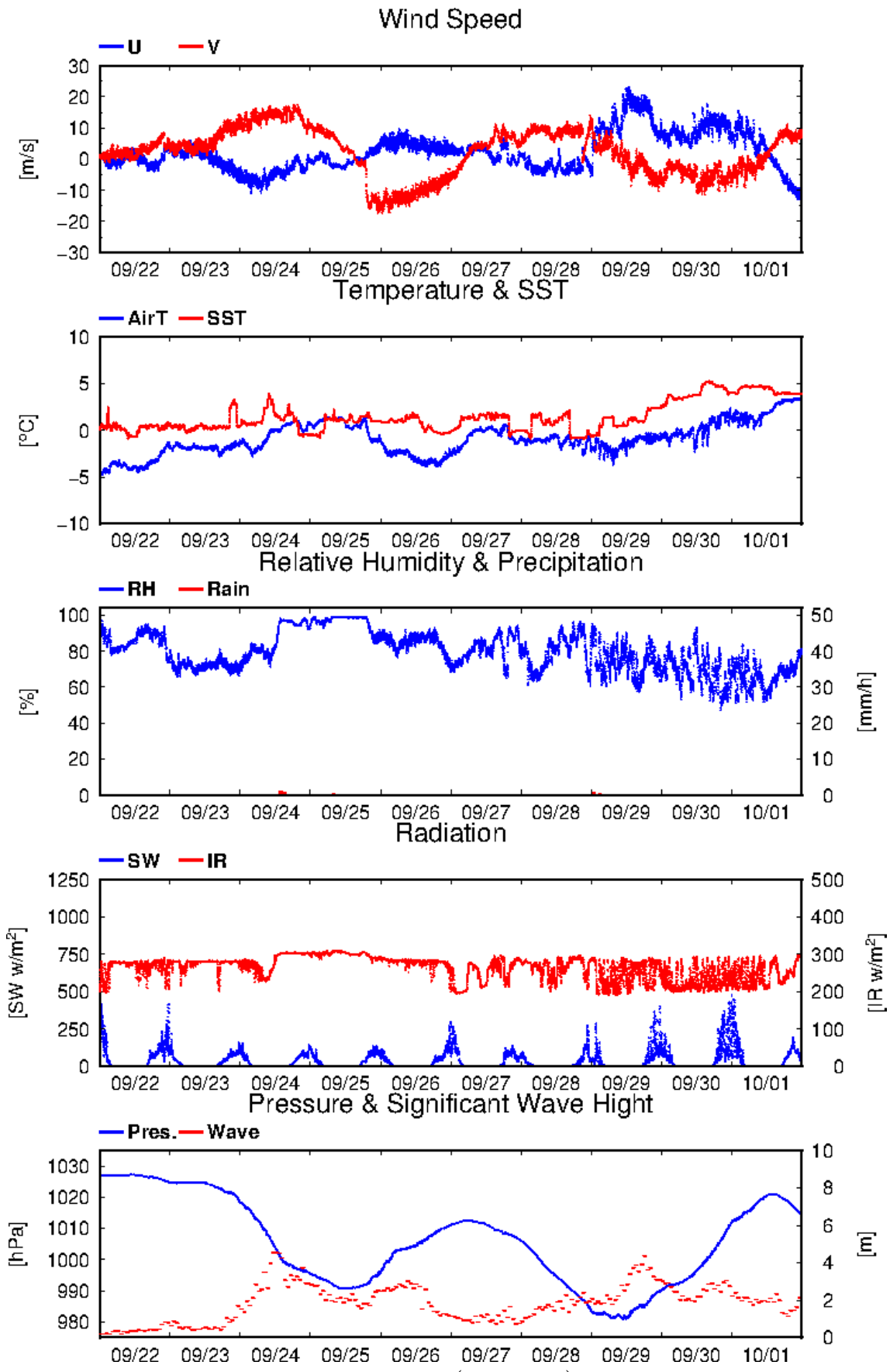

Figure 2.3-1: (Continued)

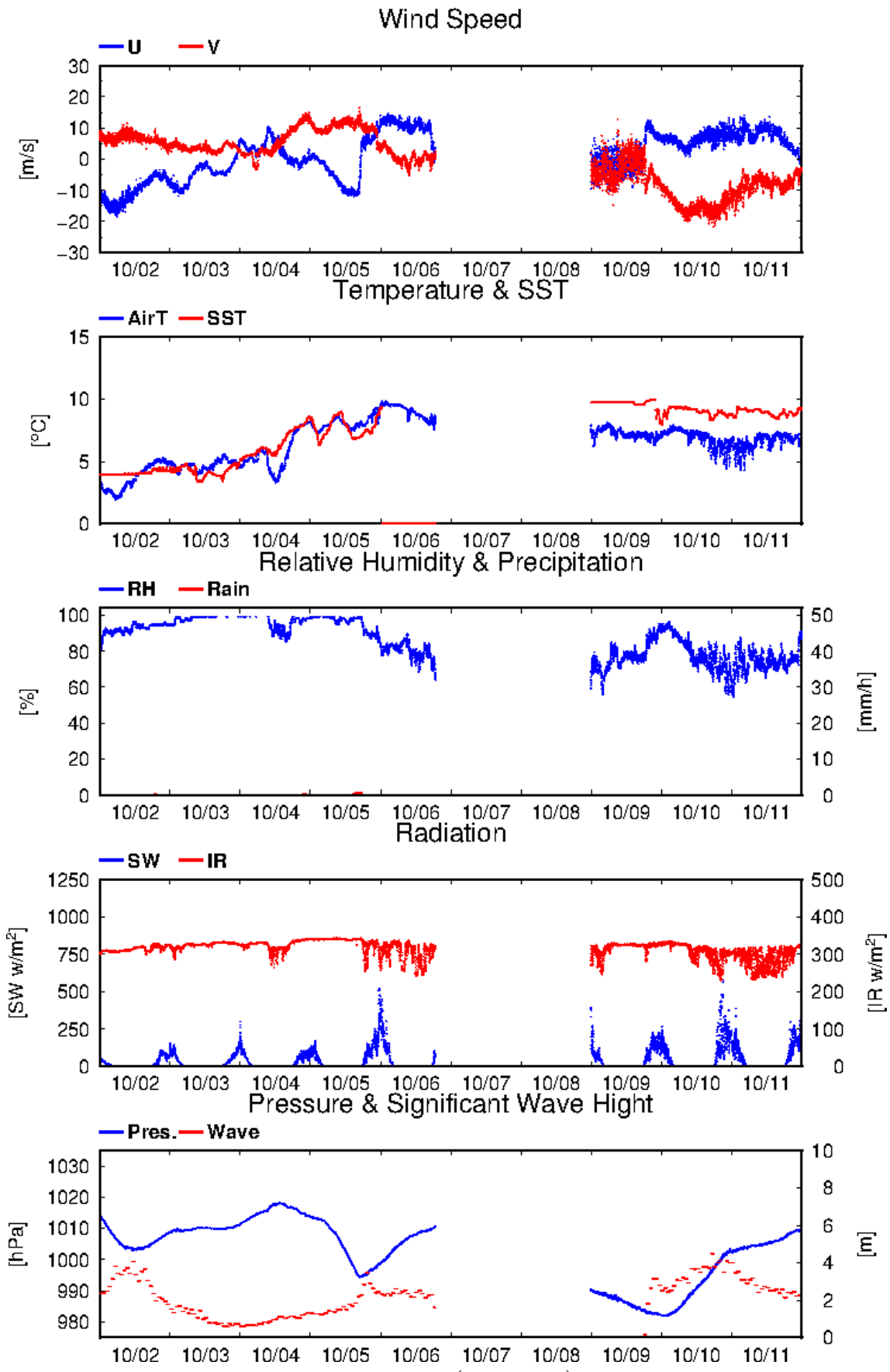

Figure 2.3-1: (Continued)

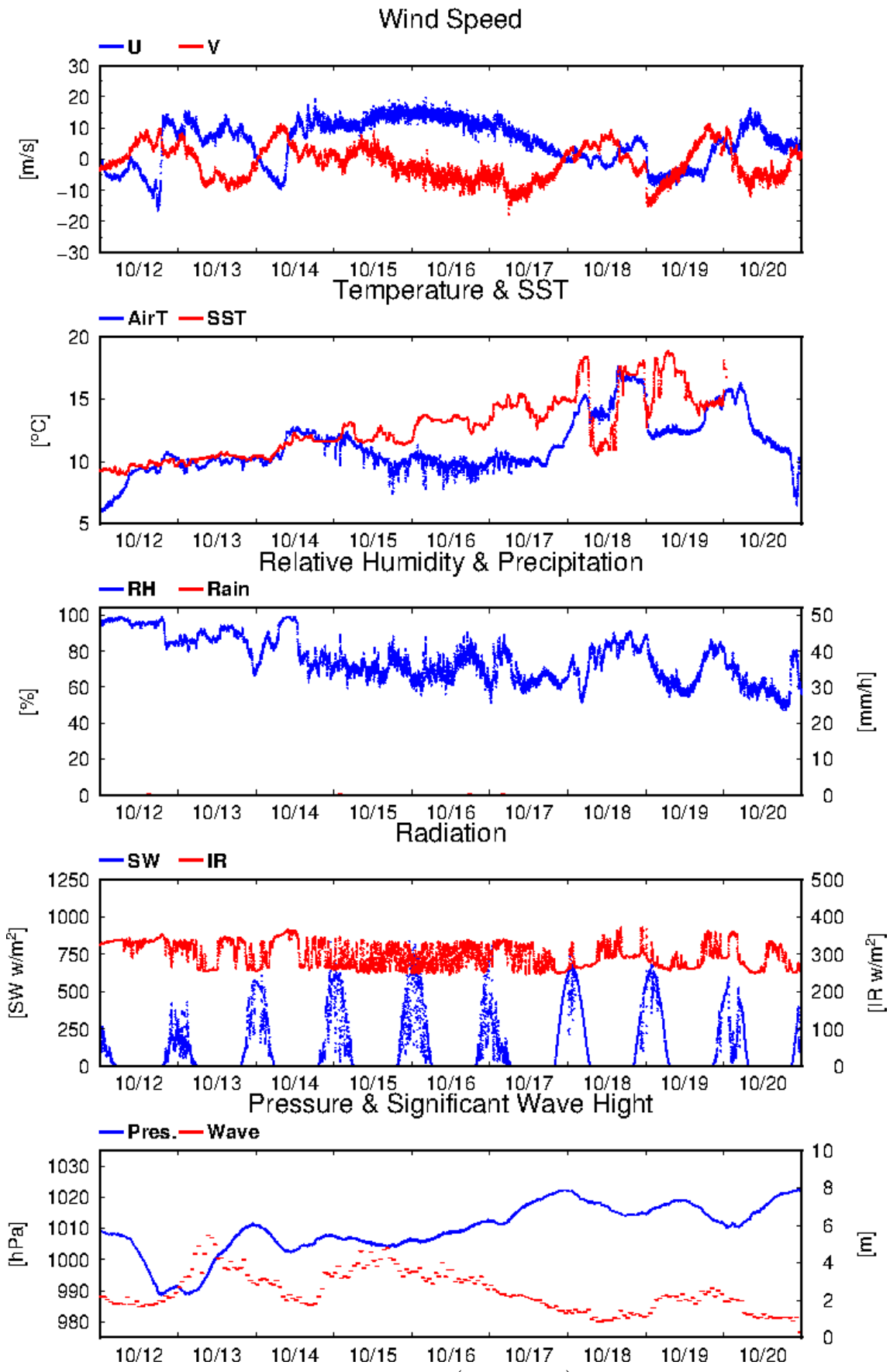

Figure 2.3-1: (Continued)

2.4 Disdrometers

(1) Personnel

Masaki KATSUMATA (JAMSTEC) - Principal Investigator

(2) Objectives

The disdrometer can continuously obtain size distribution of raindrops. The objective of this observation is (a) to reveal microphysical characteristics of the rainfall, depends on the type, temporal stage, etc. of the precipitating clouds, (b) to retrieve the coefficient to convert radar reflectivity to the rainfall amount, and (c) to validate the algorithms and the product of the satellite-borne precipitation radars; TRMM/PR and GPM/DPR.

(3) Parameters

Number and size of precipitating particles

(4) Methods

Four different types of disdrometers are utilized to obtain better reasonable and accurate value on the moving vessel. Three of the disdrometers and one optical rain gauge are installed in one place, the starboard side on the roof of the anti-rolling system of R/V Mirai, as in Fig. 2.4-1. One of the disdrometers named “micro rain radar” is installed at the starboard side of the anti-rolling systems (see Fig. 2.4-2).

The details of the sensors are described below. All the sensors archive data every one minute.

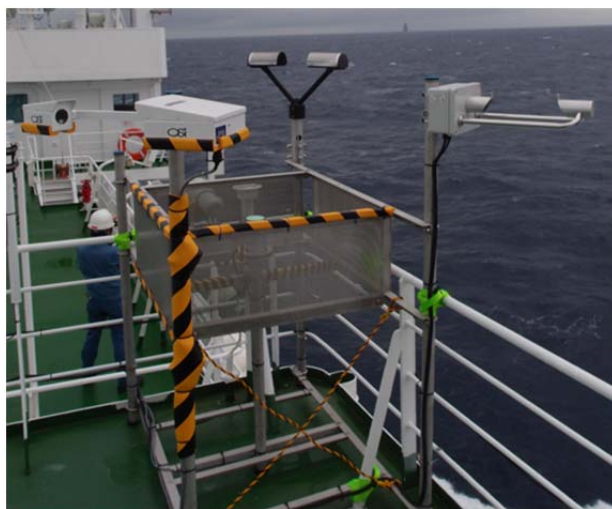

Fig. 2.4-1: The three disdrometers (Parsivel, LPM and Joss-Waldvogel disdrometer) and an optical rain gauge, installed on the roof of the anti-rolling tank.



Fig. 2.4-2: The micro rain radar, installed on the starboard side of the anti-rolling tank.

(4-1) Joss-Waldvogel type disdrometer

The “Joss-Waldvogel-type” disdrometer system (RD-80, Disdromet Inc.) (hereafter JW) equipped a microphone on the top of the sensor unit. When a raindrop hit the microphone, the magnitude of induced sound is converted to the size of raindrops. The logging program “DISDRODATA” determines the size as one of the 20 categories as in Table 2.4-1, and accumulates the number of raindrops at each category. The rainfall amount could be also retrieved from the obtained drop size distribution. The number of raindrops in each category, and converted rainfall amount, are recorded every one minute.

(4-2) Laser Precipitation Monitor (LPM) optical disdrometer

The “Laser Precipitation Monitor (LPM)” (Adolf Thies GmbH & Co) is an optical disdrometer. The instrument consists of the transmitter unit which emit the infrared laser, and the receiver unit which detects the intensity of the laser come thru the certain path length in the air. When a precipitating particle fall thru the laser, the received intensity of the laser is reduced. The receiver unit detect the magnitude and the duration of the reduction and then convert them onto particle size and fall speed. The sampling volume, i.e. the size of the laser beam “sheet”, is 20 mm (W) x 228 mm (D) x 0.75 mm (H).

The number of particles are categorized by the detected size and fall speed and counted every minutes. The categories are shown in Table 2.4-2.

(4-3) “Parsivel” optical disdrometer

The “Parsivel” (OTT Hydromet GmbH) is another optical disdrometer. The principle is same as the LPM. The sampling volume, i.e. the size of the laser beam “sheet”, is 30 mm (W) x 180 mm (D). The categories are shown in Table 2.4-3.

(4-4) Optical rain gauge

The optical rain gauge, which detect scintillation of the laser by falling raindrops, is installed beside the above three disdrometers to measure the exact rainfall. The ORG-815DR (Optical Scientific Inc.) is utilized with the controlling and recording software (manufactured by Sankosha Co.).

(4-5) Micro rain radar

The MRR-2 (METEK GmbH) was utilized. The specifications are in Table 2.4-4. The antenna unit was installed at the starboard side of the anti-rolling systems (see Fig. 2.4-2), and wired to the junction box and laptop PC inside the vessel.

The data was averaged and stored every one minute. The vertical profile of each parameter was obtained every 200 meters in range distance (i.e. height) up to 6200 meters, i.e. well beyond the melting layer. The drop size distribution is recorded, as well as radar reflectivity, path-integrated attenuation, rain rate, liquid water content and fall velocity.

(5) Preliminary Results

The data were obtained continuously thru the cruise from Aug. 24 to Oct. 22. The further analyses will be done after the cruise.

(6) Data Archive

All data obtained during this cruise will be submitted to the JAMSTEC Data Management Group (DMG).

(7) Acknowledgment

The optical rain gauge is kindly provided by National Institute for Information and Communication Technology (NICT). The operations are supported by Japan Aerospace Exploration Agency (JAXA) Precipitation Measurement Mission (PMM).

Table 2.4-1: Category number and corresponding size of the raindrop for JW disdrometer.

Category	Corresponding size range [mm]
1	0.313 - 0.405
2	0.405 - 0.505
3	0.505 - 0.696
4	0.696 - 0.715
5	0.715 - 0.827
6	0.827 - 0.999
7	0.999 - 1.232
8	1.232 - 1.429
9	1.429 - 1.582
10	1.582 - 1.748
11	1.748 - 2.077
12	2.077 - 2.441
13	2.441 - 2.727
14	2.727 - 3.011
15	3.011 - 3.385
16	3.385 - 3.704
17	3.704 - 4.127
18	4.127 - 4.573
19	4.573 - 5.145
20	5.145 or larger

Table 2.4-2: Categories of the size and the fall speed for LPM.

Particle Size			Fall Speed		
Class	Diameter [mm]	Class width [mm]	Class	Speed [m/s]	Class width [m/s]
1	≥ 0.125	0.125	1	≥ 0.000	0.200
2	≥ 0.250	0.125	2	≥ 0.200	0.200
3	≥ 0.375	0.125	3	≥ 0.400	0.200
4	≥ 0.500	0.250	4	≥ 0.600	0.200
5	≥ 0.750	0.250	5	≥ 0.800	0.200
6	≥ 1.000	0.250	6	≥ 1.000	0.400
7	≥ 1.250	0.250	7	≥ 1.400	0.400
8	≥ 1.500	0.250	8	≥ 1.800	0.400
9	≥ 1.750	0.250	9	≥ 2.200	0.400
10	≥ 2.000	0.500	10	≥ 2.600	0.400
11	≥ 2.500	0.500	11	≥ 3.000	0.800
12	≥ 3.000	0.500	12	≥ 3.400	0.800
13	≥ 3.500	0.500	13	≥ 4.200	0.800
14	≥ 4.000	0.500	14	≥ 5.000	0.800
15	≥ 4.500	0.500	15	≥ 5.800	0.800
16	≥ 5.000	0.500	16	≥ 6.600	0.800
17	≥ 5.500	0.500	17	≥ 7.400	0.800
18	≥ 6.000	0.500	18	≥ 8.200	0.800
19	≥ 6.500	0.500	19	≥ 9.000	1.000
20	≥ 7.000	0.500	20	≥ 10.000	10.000
21	≥ 7.500	0.500			
22	≥ 8.000	unlimited			

Table 2.4-3: Categories of the size and the fall speed for Parsivel.

Particle Size			Fall Speed		
Class	Average Diameter [mm]	Class spread [mm]	Class	Average Speed [m/s]	Class Spread [m/s]
1	0.062	0.125	1	0.050	0.100
2	0.187	0.125	2	0.150	0.100
3	0.312	0.125	3	0.250	0.100
4	0.437	0.125	4	0.350	0.100
5	0.562	0.125	5	0.450	0.100
6	0.687	0.125	6	0.550	0.100
7	0.812	0.125	7	0.650	0.100
8	0.937	0.125	8	0.750	0.100
9	1.062	0.125	9	0.850	0.100
10	1.187	0.125	10	0.950	0.100
11	1.375	0.250	11	1.100	0.200
12	1.625	0.250	12	1.300	0.200
13	1.875	0.250	13	1.500	0.200
14	2.125	0.250	14	1.700	0.200
15	2.375	0.250	15	1.900	0.200
16	2.750	0.500	16	2.200	0.400
17	3.250	0.500	17	2.600	0.400
18	3.750	0.500	18	3.000	0.400
19	4.250	0.500	19	3.400	0.400
20	4.750	0.500	20	3.800	0.400
21	5.500	1.000	21	4.400	0.800
22	6.500	1.000	22	5.200	0.800
23	7.500	1.000	23	6.000	0.800
24	8.500	1.000	24	6.800	0.800
25	9.500	1.000	25	7.600	0.800
26	11.000	2.000	26	8.800	1.600
27	13.000	2.000	27	10.400	1.600
28	15.000	2.000	28	12.000	1.600
29	17.000	2.000	29	13.600	1.600
30	19.000	2.000	30	15.200	1.600
31	21.500	3.000	31	17.600	3.200
32	24.500	3.000	32	20.800	3.200

Table 2.4-4: Specifications of the MRR-2.

Transmitter power	50 mW
Operating mode	FM-CW
Frequency	24.230 GHz (modulation 1.5 to 15 MHz)
3dB beam width	1.5 degrees
Spurious emission	< -80 dBm / MHz
Antenna Diameter	600 mm
Gain	40.1 dBi

2.5. Ceilometer

(1) Personnel

Shigeto Nishino	JAMSTEC: PI	Leg1
Shinya Okumura	Global Ocean Development Inc. (GODI)	Leg1
Wataru Tokunaga	GODI	Leg1
Koichi Inagaki	GODI	Leg1
Souichiro Sueyoshi	GODI	Leg2
Yutaro Murakami	GODI	Leg1, Leg2
Masanori Murakami	MIRAI Crew	Leg1, Leg2

(2) Objectives

The information of cloud base height and the liquid water amount around cloud base is important to understand the process on formation of the cloud. As one of the methods to measure them, the ceilometer observation was carried out.

(3) Parameters

1. Cloud base height [m].
2. Backscatter profile, sensitivity and range normalized at 10 m resolution.
3. Estimated cloud amount [oktas] and height [m]; Sky Condition Algorithm.

(4) Instruments and methods

We measured cloud base height and backscatter profile using ceilometer (CL51, VAISALA, Finland) throughout this cruise.

Major parameters for the measurement configuration are as follows;

Laser source:	Indium Gallium Arsenide (InGaAs) Diode Laser
Transmitting center wavelength:	910±10 nm at 25 degC
Transmitting average power:	19.5 mW
Repetition rate:	6.5 kHz
Detector:	Silicon avalanche photodiode (APD)
Measurement range:	0 ~ 15 km 0 ~ 13 km (Cloud detection)
Resolution:	10 meter in full range
Sampling rate:	36 sec
Sky Condition	0, 1, 3, 5, 7, 8 oktas (9: Vertical Visibility) (0: Sky Clear, 1: Few, 3: Scattered, 5-7: Broken, 8: Overcast)

On the archive dataset, cloud base height and backscatter profile are recorded with the resolution of 10 m.

(5) Preliminary results

Figure 2.5-1 shows the time series of cloud-base heights derived from the ceilometer during this cruise.

(6) Data archives

These data obtained in this cruise will be submitted to the Data Management Group of JAMSTEC, and will be opened to the public via “Data Research System for Whole Cruise Information in JAMSTEC (DARWIN)” in JAMSTEC web site.

<<http://www.godac.jamstec.go.jp/darwin/e>>

(7) Remarks

1. Window cleaning:

07:58UTC 26 Aug. 2015

01:37UTC 03 Sep. 2015

00:19UTC 14 Sep. 2015

22:19UTC 27 Sep. 2015

03:03UTC 04 Oct. 2015

16:03UTC 09 Oct. 2015

01:25UTC 14 Oct. 2015

04:02UTC 17 Oct. 2015

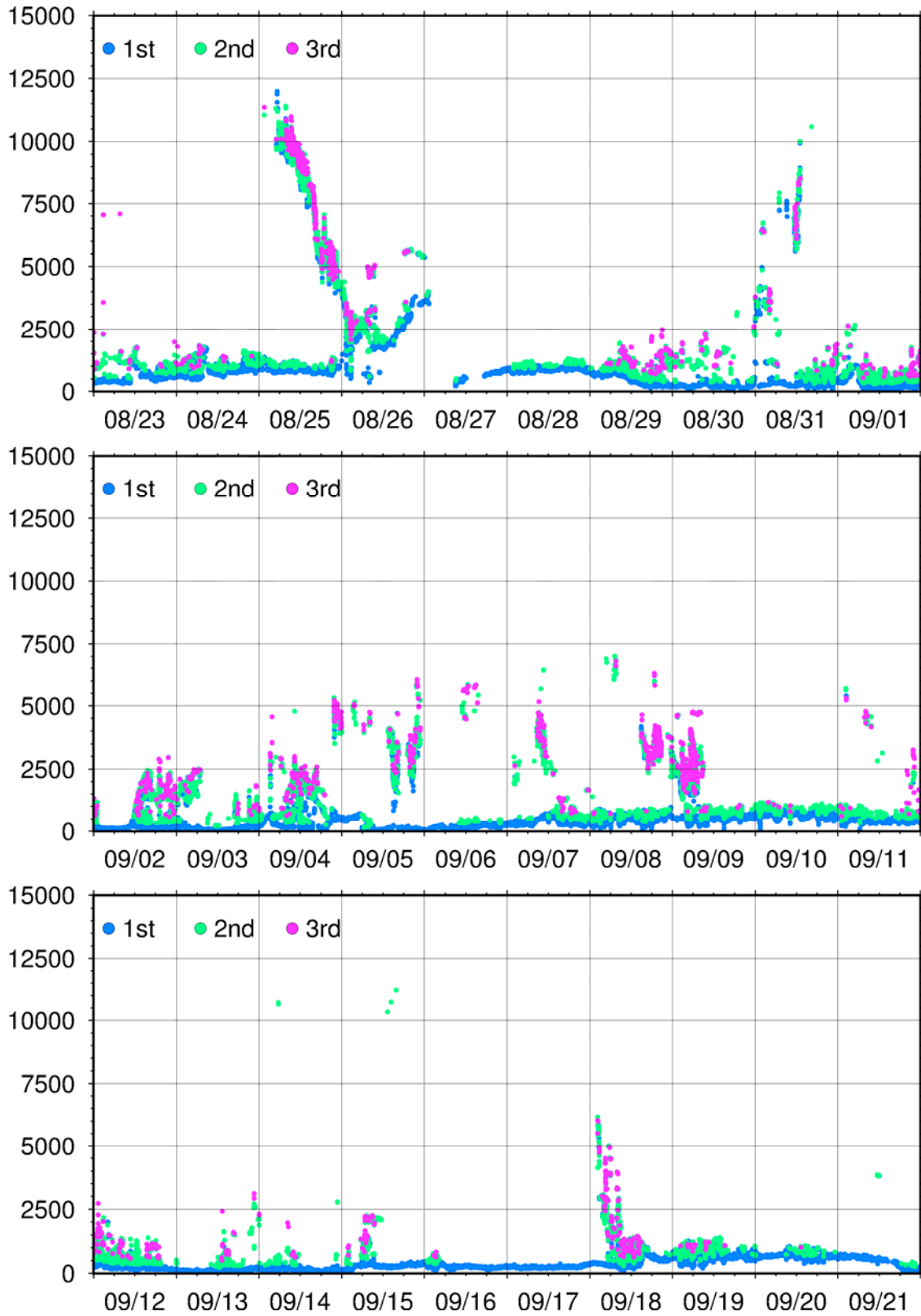

Figure 2.5-1: Time series of cloud base height during this cruise

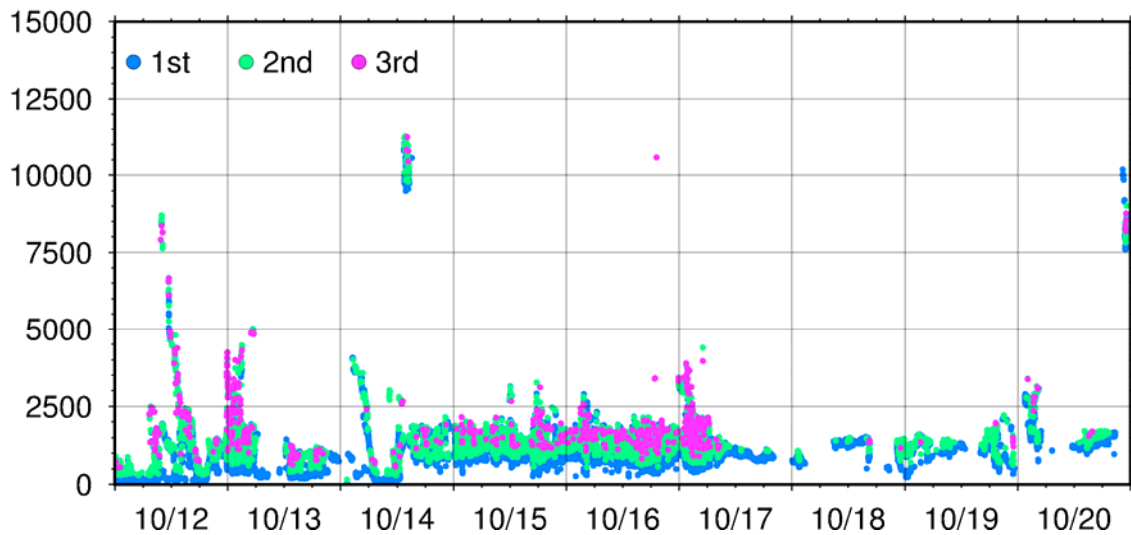
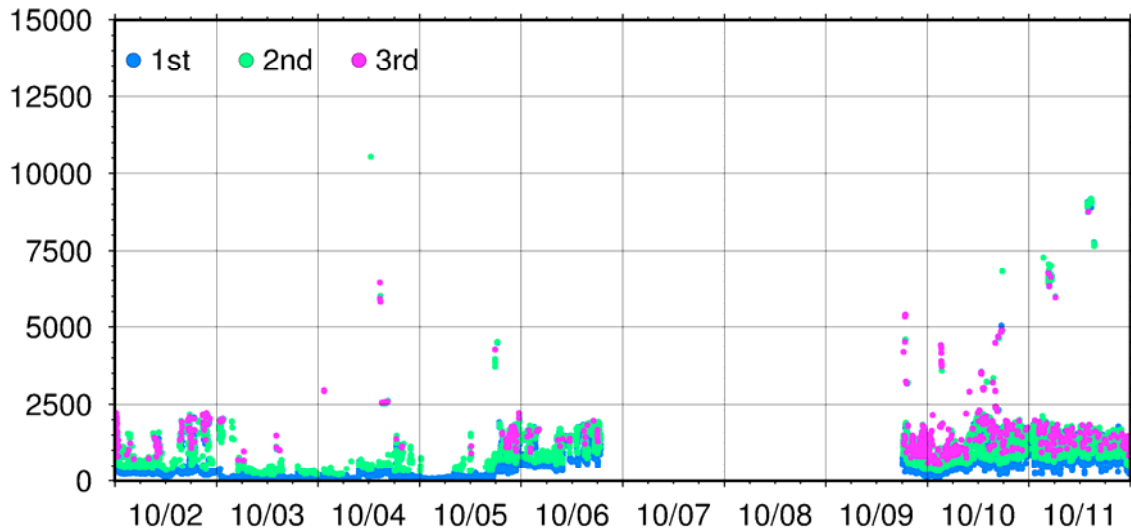
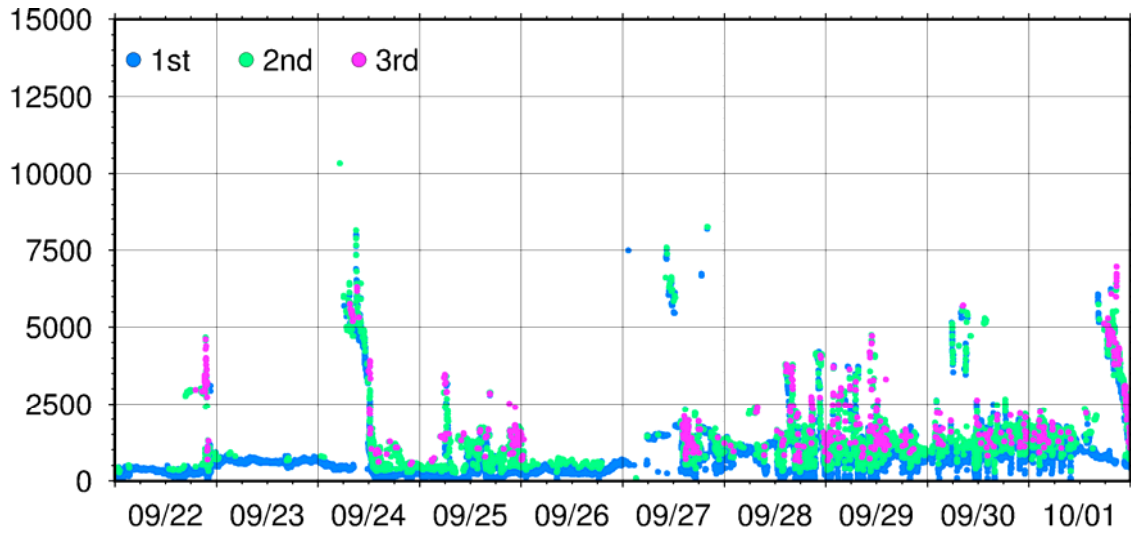

Figure 2.5-1: (Continued)

2.6. Greenhouse gases

2.6.1. Continuous measurements

(1) Personnel

Masao Ishii	Meteorological Research Institute: Principal Investigator
Yasunori Tohjima	National Institute for Environmental Studies
Keiichi Katsumata	National Institute for Environmental Studies
Sohiko Kameyama	Hokkaido University

(2) Objective

In arctic region, there are a lot of vulnerable carbon pools, which have the potential to become strong sources of CO₂ and CH₄ release into the atmosphere when the destabilization occurs through climate change. Therefore, it is important to understand the current situation of the greenhouse gas emissions around the arctic region. The purpose of present study is to observe the atmospheric CO₂ and CH₄ mixing ratios during the cruise, detect the enhanced mixing ratios associated with the regional emissions, and estimate the distribution of the regional emission sources. The atmospheric CO mixing ratios, which are also observed at the same time, can be used as an indicator of the anthropogenic emissions associated with the combustion processes.

(3) Parameters

Mixing ratio of atmospheric CO₂, CH₄, and CO.

(4) Instruments and Methods

Atmospheric CO₂, CH₄, and CO mixing ratios were measured by a wavelength-scanned cavity ring-down spectrometer (WS-CRDS, Picarro, G2401). An air intake, capped with an inverted stainless steel beaker covered with stainless steel mesh, was placed on the right-side of the upper deck. A diaphragm pump (GAST, MOA-P108) was used to draw in the outside air at a flow rate of ~8 L min⁻¹. Water vapor in the sample air was removed to a dew pint of about 2°C and about -35°C by passing it through a thermoelectric dehumidifier (KELK, DH-109) and a Nafion drier (PERMA PURE, PD-50T-24), respectively. Then, the dried sample air was introduced into the WS-CRDS at a flow rate of 100 ml min⁻¹. The WS-CRDS were automatically calibrated every 25 hour by introducing 3 standard airs with known CO₂, CH₄ and CO mixing ratios. The analytical precisions for CO₂, CH₄, and CO mixing ratios are about 0.02 ppm, 0.3 ppb and 3 ppb, respectively.

(5) Observation log

The shipboard measurements were conducted during the entire cruise.

(6) Data archives

These data obtained in this cruise will be submitted to the Data Management Group of JAMSTEC, and will be opened to the public via “Data Research System for Whole Cruise Information in JAMSTEC (DARWIN)” in JAMSTEC web site.

2.6.2. Discrete flask sampling

(1) Personnel

Masao Ishii	Japan Meteorological Agency: Principal Investigator
Shuji Aoki	Tohoku University
Shigeyuki Ishidoya	National Institute of Advanced Industrial Science and Technology (AIST)
Sohiko Kameyama	Hokkaido University
Yasunori Tohjima	National Institute for Environmental Studies
Hiroshi Uchida	JAMSTEC
Daisuke Sasano	Japan Meteorological Agency
Naohiro Kosugi	Japan Meteorological Agency
Shinji Morimoto	National Institute of Polar Research
Hisayuki Yoshikawa	Hokkaido University
Chika Minejima	Tokyo University of Agriculture and Technology
Daisuke Goto	Tohoku University
Shoichi Taguchi	National Institute of Advanced Industrial Science and Technology (AIST)
Kentaro Ishijima	JAMSTEC
Prabir Patra	JAMSTEC
Shohei Murayama	National Institute of Advanced Industrial Science and Technology (AIST)

(2) Objective

In order to clarify space variations and air-sea exchanges of the green house gases at northern high latitude, air samples were collected into 40 stainless-steel flasks on the Western North Pacific and the Arctic Ocean. The collected air samples will be analyzed for the concentrations of CO₂, O₂, Ar, CH₄, CO, N₂O and SF₆ and the isotopic ratios of CO₂ and CH₄.

(3) Parameters

Atmospheric CO₂ concentration, O₂/N₂ ratio (O₂ concentration), Ar/N₂ ratio (Ar concentration), CH₄ concentration, CO concentration, N₂O concentration, SF₆ concentration, $\delta^{13}\text{C}$ of CO₂, $\delta^{18}\text{O}$ of CO₂, $\delta^{13}\text{C}$ of CH₄ and δD of CH₄.

(4) Instruments and Methods

The air sampling equipment consisted of an air intake, a piston pump (GAST LOA), a water trap, solenoid valves (CKD), an ethanol bath as refrigerant, a flow meter and an immersion cooler (EYELA ECS-80). Ambient air was pumped using a piston pump from an air intake and dried cryogenically, and filled into a 1 L stainless-steel flask at a pressure of 0.55 MPa.

(5) Station list or Observation log

The air samplings were conducted once/twice a day. Table 2.6.2-1 shows time and position of each sampling.

Table 2.6.2-1: Date and position of the air flask sampling.

Flask No.	Sampling date and time (yyyy/mm/dd hh:mm UTC)	Sampling Position
B001	2015/08/27 05:21	40-16N, 146-07E
B002	2015/08/28 03:20	40-32N, 150-34E
B003	2015/08/29 01:48	42-39N, 153-46E
B004	2015/08/30 05:59	42-39N, 153-46E
B005	2015/08/31 04:54	47-42N, 161-56E
B006	2015/09/01 07:14	50-32N, 166-50E
B009	2015/09/02 02:13	52-44N, 170-56E
B010	2015/09/03 08:05	56-48N, 177-28E
No. 42	2015/09/04 11:25	61-09N, 175-59W
B012	2015/09/05 01:48	63-52N, 172-14W
B016	2015/09/06 02:02	65-04N, 168-38W
B029	2015/09/07 07:17	68-36N, 168-45W
B032	2015/09/08 05:23	71-03N, 166-51W
B035	2015/09/09 06:23	71-21N, 157-24W
B037	2015/09/11 07:37	71-51N, 155-58W
B038	2015/09/13 10:55	72-11N, 150-20W
No. 41	2015/09/15 10:44	72-19N, 150-40W
A009	2015/09/22 02:17	72-10N, 155-53W
A016	2015/09/23 11:53	72-13N, 156-06W
A025	2015/09/25 01:17	73-12N, 157-47W
A032	2015/09/25 10:13	72-47N, 160-58W
A041	2015/09/26 09:59	73-11N, 162-13W
D005	2015/09/26 15:29	73-17N, 160-39W
D006	2015/09/27 06:03	73-00N, 161-18W
D010	2015/09/28 06:06	73-30N, 162-45W
No. 8	2015/09/29 00:29	74-30N, 168-45W
D013	2015/09/29 00:43	74-30N, 168-44W
D014	2015/09/29 12:01	73-15N, 168-39W
D017	2015/10/01 02:42	68-16N, 168-44W
D027	2015/10/01 10:19	68-51N, 168-45W
D045	2015/10/01 13:45	68-22N, 168-46W
D054	2015/10/02 00:55	68-01N, 168-49W
D056	2015/10/02 01:09	68-01N, 168-49W
D057	2015/10/03 04:39	67-50N, 168-53W
No. 3	2015/10/03 14:55	66-11N, 168-44W
B011	2015/10/03 18:41	65-51N, 168-37W
B039	2015/10/03 23:51	64-56N, 168-41W
D011	2015/10/04 08:33	63-20N, 167-38W
D059	2015/10/04 22:51	60-49N, 167-44W
No. 57	2015/10/05 08:40	59-04N, 167-42W
No. 2	2015/10/05 17:08	57-42N, 167-22W

(6) Data archives

These data obtained in this cruise will be submitted to the Data Management Group of JAMSTEC, and will be opened to the public via “Data Research System for Whole Cruise Information in JAMSTEC (DARWIN)” in JAMSTEC web site.

2.6.3. Stable isotope measurements

(1) Personnel

Nobuyoshi Yamashita	National Institute of Advanced Industrial Science and Technology -PI
Kosuke Noborio	Meiji University
Yuki Ito	Meiji University
Shujiro Komiya	Meiji University

(2) Objective

The exchange of methane (CH₄) and carbon dioxide (CO₂) at the air-sea interface is a major contributor to the global carbon cycle. Previous studies have theoretically estimated their exchange rates by the bulk method, i.e. a gas concentration gradient between in the air and in the seawater multiplied by a gas transfer coefficient usually as a function of wind speed. Recent advancement in computers and microelectronics enabled devices to measure CO₂ concentration and three-dimensional wind speed with the time scan rate of >10 Hz. Using those instruments a standard micrometeorological procedure, e.g., eddy covariance (EC), was established to directly measure CO₂ flux in a real time manner on the ground or above the tree canopy. Kondo and Tsukamoto (2007) applied the EC procedure to directly measure CO₂ flux at the air-sea interface with the aid of a 3-axis inclinometer and accelerometer boarding on a ship. They reported that the CO₂ flux measured with the micrometeorological method was as large as 20 times that estimated with the conventional bulk method. Not much research has been reported on the direct measurement of CH₄ flux at the air-sea interface because of few high-speed instruments available for measuring CH₄ concentration until a few years back. Our research group has developed another micrometeorological procedure, e.g., relaxed eddy accumulation (REA), and successfully applied to agricultural fields. Although the REA does not require a high-speed instrument to measure gas concentration, results are comparable to those with the EC. We're interested to apply our REA to the air-sea interface. The objectives of our research were to map CH₄ and CO₂ flux at the air-sea interface along the meridian in the Arctic Ocean with MR-15-03 in 2015 and to complete the CH₄ and CO₂ flux map in the Arctic Ocean.

(3) Parameters

Concentration of atmospheric CO₂, CH₄, and their isotope
3-dimensional wind direction and velocity
3-axis inclination and acceleration
Net radiation
GPS data

(4) Instruments and Methods

Air was separately collected into 2 L plastic bins according to upward and downward wind measured with a 3-dimensional ultrasonic anemometer (SAT540, Sonic Inc., Tokyo) installed on the compass deck of R/V Mirai approximately 20m above the sea surface. A 3-axis inclinometer and accelerometer (MotionPak II, Bei Technologies In.,

Concord, CA) and a net radiometer (hand-made in our lab.) were installed at the same compass deck as well. The concentration of CH₄ and CO₂ and $\delta^{13}\text{C}$ of CH₄ and CO₂ in the air separately collected in 2 L bins were alternatively measured every 3 min with a CO₂/CH₄/ $\delta^{13}\text{C}$ laser gas analyzer (G2201-i, Picarro Inc., Santa Clara, CA) installed in Environmental Research Lab. Gas flux at the air-sea interface was evaluated as (McInnes and Heilman, 2005):

$$J = B\sigma_w(\overline{C_u} - \overline{C_d}) \times 3600 \quad [1]$$

where J is the flux of a specific gas (mg/m²/h), B is an empirical constant, σ_w is the standard deviation of vertical wind speed (m/s), C_u and C_d are 30 min average gas concentrations in bins for upward and downward winds, respectively (g/m³).

(5) Observation log

The shipboard measurements were conducted during the entire cruise.

(6) Data archives

These data obtained in this cruise will be submitted to the Data Management Group of JAMSTEC, and will be opened to the public via “Data Research System for Whole Cruise Information in JAMSTEC (DARWIN)” in JAMSTEC web site.

(7) Referances

Kondo, F., and O. Tsukamoto. 2007. Air-sea CO₂ flux by eddy covariance technique in the equatorial Indian ocean. *J. Oceanography* 63:449-456.
 McInnes, K.J., and J.L. Heilman. 2005. Relaxed eddy accumulation. pp. 437-454. In Hatfield et al. (eds.) *Micrometeorology in agricultural systems*. Agronomy monograph no. 47. ASA-CSSA-SSSA, Madison, WI.

2.7. Tropospheric gas and aerosol particles: Black carbon and others

(1) Personnel

Yugo KANAYA (JAMSTEC DEGCR, not on board)
Fumikazu TAKETANI (JAMSTEC DEGCR, not on board)
Takuma MIYAKAWA (JAMSTEC DEGCR, not on board)
Hisahiro TAKASHIMA (JAMSTEC DEGCR, not on board)
Yuichi KOMAZAKI (JAMSTEC DEGCR, not on board)
Hitoshi MATSUI (JAMSTEC DEGCR, not on board)
Kazuhiko MATSUMOTO (JAMSTEC DEGCR, not on board)
Operation was supported by Global Ocean Development Inc.

(2) Objectives

- To investigate roles of aerosols and gases, including black carbon and ozone, in the marine atmosphere in relation to climate change
- To investigate processes of biogeochemical cycles between the atmosphere and the ocean

(3) Parameters

- Black carbon (BC) and fluorescent particles
- Aerosol optical depth (AOD) and aerosol extinction coefficient (AEC)
- Surface ozone (O₃), and carbon monoxide (CO) mixing ratios

(4) Instruments and methods

(4-1) Online aerosol observations: black carbon (BC) and fluorescent properties

BC and fluorescent properties of aerosol particles were measured by the instruments based on laser-induced incandescence (SP2, Droplet Measurement Technologies) and on flash-lamp-induced fluorescence (WIBS4, Droplet Measurement Technologies). The measurements of fluorescent properties by WIBS4 were made on the flying bridge. Two pulsed xenon lamps emitting UV light (280 nm and 370 nm) were used for excitation and fluorescence emitted from a single particle within 310–400 nm and 420–650 nm wavelength windows was recorded.

For SP2, ambient air was sampled from the flying bridge by a 3-m-long conductive tube through a Diffusion Dryer (model TSI) to dry up the particles, and then introduced to the instrument for detection of single particles of BC.

(4-2) MAX-DOAS

Multi-Axis Differential Optical Absorption Spectroscopy (MAX-DOAS), a passive remote sensing technique measuring spectra of scattered visible and ultraviolet (UV) solar radiation, was used for atmospheric aerosol and gas profile measurements. Our MAX-DOAS instrument consists of two main parts: an outdoor telescope unit and an

indoor spectrometer (Acton SP-2358 with Princeton Instruments PIXIS-400B), connected to each other by a 14-m bundle optical fiber cable. The line of sight was in the directions of the portside of the vessel and the measurements were made at several elevation angles of 1.5, 3, 5, 10, 20, 30, 90 degrees using a movable prism, which repeated the same sequence of elevation angles every ~15-min. For the selected spectra recorded with elevation angles with good accuracy, DOAS spectral fitting was performed to quantify the slant column density (SCD) of NO₂ (and other gases) and O₄ (O₂-O₂, collision complex of oxygen) for each elevation angle. Then, the O₄ SCDs were converted to the aerosol optical depth (AOD) and the vertical profile of aerosol extinction coefficient (AEC) using an optimal estimation inversion method with a radiative transfer model. Using derived aerosol information, retrievals of the tropospheric vertical column/profile of NO₂ and other gases were made.

(4-3) CO and O₃

Ambient air was continuously sampled on the compass deck and drawn through ~20-m-long Teflon tubes connected to a gas filter correlation CO analyzer (Model 48C, Thermo Fisher Scientific) and a UV photometric ozone analyzer (Model 49C, Thermo Fisher Scientific), located in the Research Information Center. The data will be used for characterizing air mass origins.

(5) Observation log

The shipboard measurements and sampling were continuously conducted in the open sea.

(6) Preliminary results

N/A (All the data analysis is to be conducted.)

(7) Data archives

These data obtained in this cruise will be submitted to the Data Management Group of JAMSTEC, and will be opened to the public via “Data Research System for Whole Cruise Information in JAMSTEC (DARWIN)” in JAMSTEC web site.

<<http://www.godac.jamstec.go.jp/darwin/e>>

2.8 Aerosol optical characteristics measured by ship-borne sky radiometer

(1) Personnel

Kazuma Aoki (University of Toyama) Principal Investigator / not onboard
Tadahiro Hayasaka (Tohoku University) Co-worker / not onboard
Sky radiometer operation was supported by Global Ocean Development Inc.

(2) Objective

Objective of this observation is to study distribution and optical characteristics of marine aerosols by using a ship-borne sky radiometer (POM-01 MKII: PREDE Co. Ltd., Japan). Furthermore, collections of the data for calibration and validation to the remote sensing data were performed simultaneously.

(3) Parameters

- Aerosol optical thickness at five wavelengths (400, 500, 675, 870 and 1020 nm)
- Ångström exponent
- Single scattering albedo at five wavelengths
- Size distribution of volume (0.01 μm – 20 μm)
- # GPS provides the position with longitude and latitude and heading direction of the vessel, and azimuth and elevation angle of the sun. Horizon sensor provides rolling and pitching angles.

(4) Instruments and Methods

The sky radiometer measures the direct solar irradiance and the solar aureole radiance distribution with seven interference filters (0.34, 0.4, 0.5, 0.675, 0.87, 0.94, and 1.02 μm). Analysis of these data was performed by SKYRAD.pack version 4.2 developed by Nakajima *et al.* 1996.

(5) Data archives

Aerosol optical data are to be archived at University of Toyama (K.Aoki, SKYNET/SKY: <http://skyrad.sci.u-toyama.ac.jp/>) after the quality check and will be submitted to JAMSTEC.

2.9. Perfluoroalkyl substances (PFASs)

(1) Personnel

Nobuyoshi Yamashita	National Institute of Advanced Industrial Science and Technology (AIST)	- PI
Hui GE	AIST	

(2) Objective

Environmentally persistent perfluoroalkyl substances (PFASs, shown in Figure 2.9-1) have appeared as a new class of global pollutants.

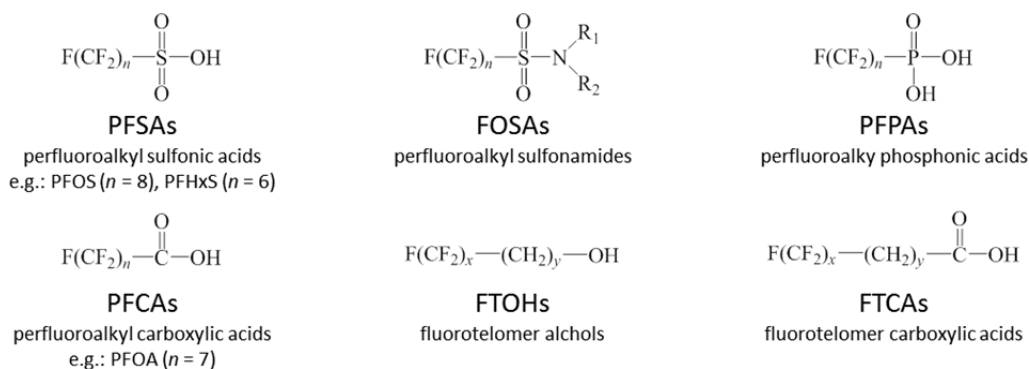

Figure 2.9-1: Perfluoroalkyl substances (PFASs)

These compounds have recently emerged as a priority environmental pollutant due to its widespread finding in biota including both Arctic and Antarctic species and its persistent and bioaccumulative nature, especially for PFOS (perfluorooctane sulfonate) and PFOA (perfluorooctane carboxylic acid). The physicochemical properties of PFASs, especially of PFSA (perfluoroalkyl sulfonic acids) and PFCAs (perfluoroalkyl carboxylic acids) are unique in that they have high water solubility despite the low reactivity of carbon-fluorine bond, which also imparts high stability in the environment.

PFOS was found in polar bears in the Arctic. It is the evidence that PFOS was transported to the Polar region by long-range transportation. However it is not well known about environmental fate of PFASs, especially for global transportation. It is important to determine environmental fate of PFASs such as the mechanism of global transport and distribution of PFASs, especially in the Polar region.

In MR15-03, we will survey PFASs in the air and precipitation on the Arctic Ocean to understand global distribution of PFASs.

(3) Parameters

Perfluoroalkyl substances (PFASs)

(4) Instruments and Methods

Air samples were taken with three kinds of sampler. One is a comprehensive cryogenic moisture sampler (CMS; prototype type 5) which was developed by AIST and SIBATA Co (Figure 2.9-2). This air sampler was operated with a flow rate of 20 L/min. Gas and particle phase of PFASs in atmosphere were collected into bubbler solvent consisted of methanol in Milli-Q water by bubbling and then trapped into cold trap by cooling with -4 °C. The other two kinds sampler are both cascade impactor (Figure 2.9-3). One is nanosampler (NS40), operated at 40L/min. The inlet and filter stages allowed collection of particles in six size fractions including particle diameter (dp) greater than 10µm and less than 0.1µm (specifically, >10, 10–2.5, 2.5–1, 1–0.5, 0.5–0.1 and < 0.1 µm, respectively). The other cascade impactor was operated at 20L/min (NS20U), separating particles to >10, 10–2.5, 2.5–1, and < 1 µm.

Samples were collected during underway and CTD operation. To avoid contamination from exhaust gas from ship, all samplers were connected with wind select unit. Only if the relative wind direction condition was between 110~250° and relative wind speed condition was between 7m/s to 100m/s, the air samplers were working.

Precipitation samples were also collected using polypropylene funnel (16.5 cm φ).

Air and precipitation samples were stored in clean polypropylene boxes or bottles and were kept frozen at below -20°C until analysis.

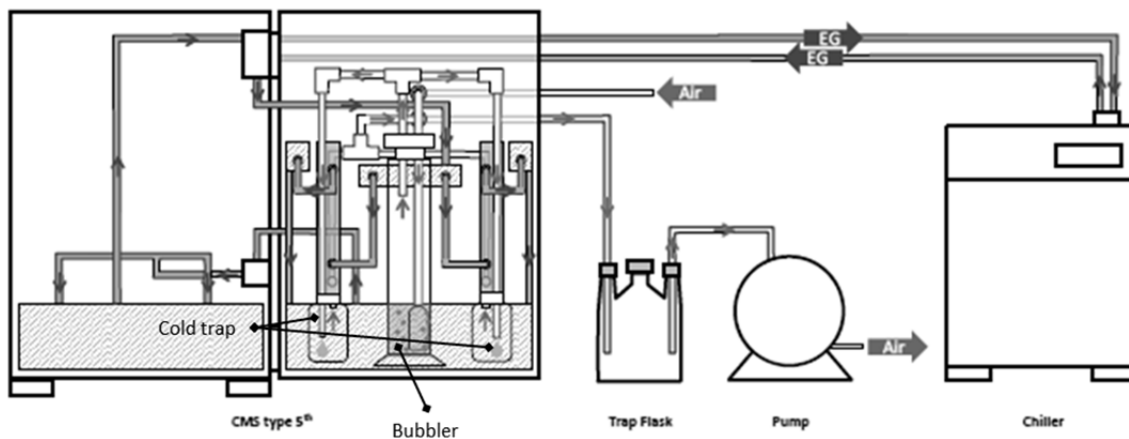

Figure 2.9-2: Schematic diagram of CMS type 5th system

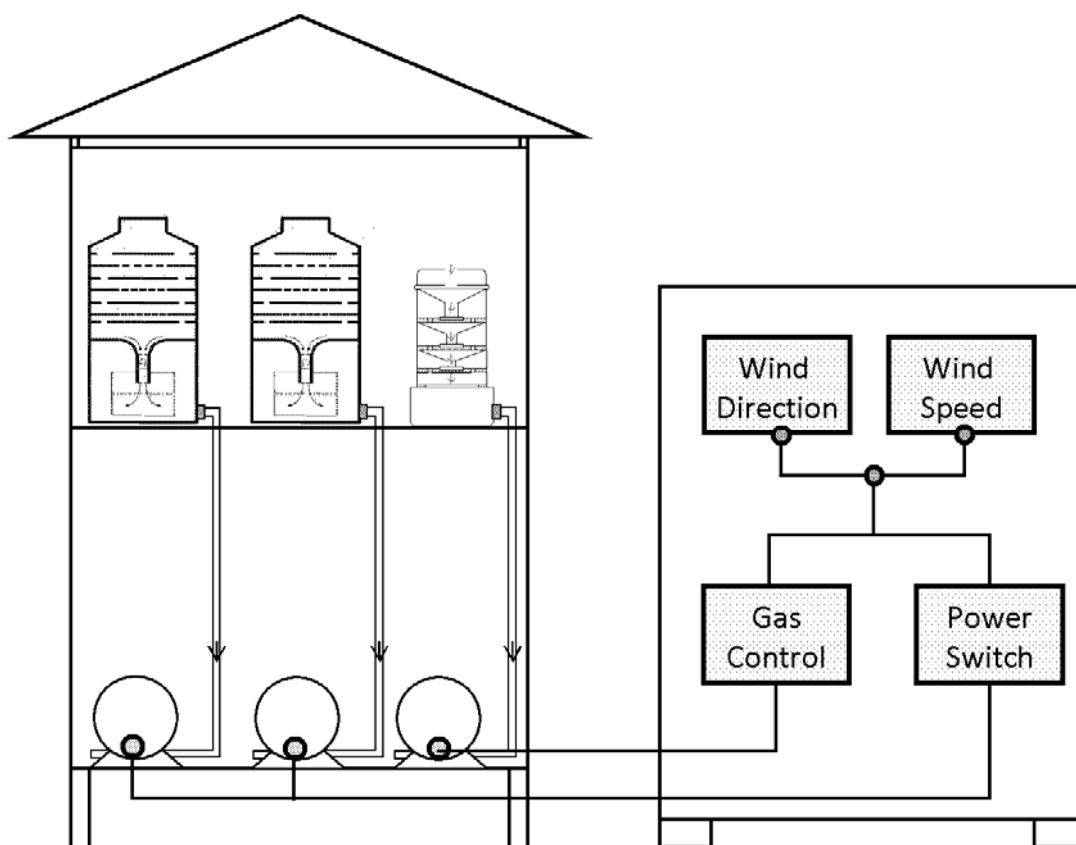

Figure 2.9-3: Schematic diagram of Cascade impactor sampling system

CMS Samples and precipitation samples were thawed at room temperature, and a solid phase extraction method using Oasis®WAX cartridge (150 mg, 30 µm) (Waters Co.)⁽¹⁻³⁾. The HPLC tandem mass spectrometry (HPLC-MS/MS) was used for sample analysis⁽¹⁻³⁾. Briefly, after preconditioning with ammonium hydroxide in methanol,

methanol, and then Millipore water, the cartridges were loaded water samples at approximately 1 drop sec⁻¹. Seawater samples were adjusted pH3 by acetic acid and then spiked surrogate standard (1 ng of each compound) before sample loading. The cartridges were then washed with Milli-Q water and then 25 mM ammonium acetate buffer (pH 4) in Milli-Q water and dried. The elution was then divided into two fractions. The first fraction was carried out with methanol and the second with 0.1% ammoniumhydroxide in methanol. Both fractions were reduced to 1 mL under a nitrogen stream and analyzed separately. HPLC-MS/MS, composed of a HP1100 liquid chromatograph (Agilent Technologies, Palo Alto, CA) interfaced with a Micromass® (Beverly, MA) Quattro Ultima Pt mass spectrometer was operated in the electrospray negative ionization mode. A 10-µL aliquot of the sample extract was injected into a Betasil C18 column (2.1 mm i.d. × 50 mm length, 5 µm; Termo Hypersil-Keystone, Bellefonte, PA). The capillary is held at 1.2 kV. Cone-gas and desolvation-gas flows are kept at 60 and 650 L/h, respectively. Source and desolvation temperatures were kept at 120 and 420°C respectively. MS/MS parameters are optimized so as to transmit the [M-K]⁻ or [M-H]⁻ ions.

As to cascade impator samples, mainly two procedures were adapted in these experiments. One was filter weighing. Ambient particles were collected on quartz fiber filters (QFF, Pallflex, 2500QAT- UP) except at the 0.1-0.5µm stage, where inertial filter cartridge along with stainless steel fiber was used. QFF were pre-baked at 400 °C for 3 hours to remove possible contamination. All filters were conditioned at 21.5°C and 35% RH in a weighing chamber (Tokyo dyrec PWS-PM2.5) for 48 hours and the weight was measured using a Sartorius M5-F microbalance (readability to 1 µg) before and after the sampling. The other procedure was the filter extraction. Particle samples were collected and extracted using methanol and measured using HPLC-tandem mass spectrometry.

Filter was put into a PP tube and sonic extracted (10min, 40°) with methanol (4mL*3 times). The supernatant was collected in a new PP tube, concentrated to 1mL and used for the cleanup with Supelclean ENVI- Carb cartridges (100 mg, 1 mL, 100-400 mesh, Supelco, U.S.A.). The conditioning of the cartridges was carried out three times with 1 mL of methanol. Afterward, the sample extract and then three times 1 mL of methanol were added to the cartridge and directly collected in another PP tube. Finally, the extract was concentrated to 1 mL under a nitrogen stream and transferred into a vial for analysis.

(5) Observation log

List of air and precipitation samples were presented in Table 2.9-1 and in Table

2.9-2, respectively.

Table 2.9-1: Summary of air sample for PFASs analysis

On board ID	Date Collected					Latitude			Longitude		
	YYYY	MM	DD	hh : mm : ss	UTC/JST	Deg.	Min.	N/S	Deg.	Min.	E/W
MR15-03-AR01	2015	8	26	11:18	UTC	40	28.23	N	142	00.71	E
MR15-03-AR02	2015	9	30	07:15	UTC	70	57.52	N	168	44.75	W
MR15-03-AR03	2015	10	3	22:55	UTC	65	04.11	N	168	38.80	W
MR15-03-AR04	2015	10	9	22:57	UTC	54	13.76	N	164	09.76	W
MR15-03-AR05	2015	10	17	00:08	UTC	43	48.08	N	159	58.10	E
MR15-03 NS20U-1	2015	8	26	11:18	UTC	40	28.23	N	142	00.71	E
MR15-03 NS20U-2	2015	9	6	22:32	UTC	67	44.65	N	168	45.31	W
MR15-03 NS20U-3	2015	9	18	01:35	UTC	72	17.76	N	155	15.39	W
MR15-03 NS20U-4	2015	9	27	04:50	UTC	73	18.04	N	160	47.07	W
MR15-03 NS20U-5	2015	10	3	22:55	UTC	65	04.11	N	168	38.80	W
MR15-03 NS20U-6	2015	10	9	22:57	UTC	54	13.76	N	164	09.76	W
MR15-03 NS20U-7	2015	10	17	00:08	UTC	43	48.08	N	159	58.10	E
MR15-03 NS40A-1	2015	8	26	11:18	UTC	40	28.23	N	142	00.71	E
MR15-03 NS40A-2	2015	9	6	22:32	UTC	67	44.65	N	168	45.31	W
MR15-03 NS40A-3	2015	9	18	01:35	UTC	72	17.76	N	155	15.39	W
MR15-03 NS40A-4	2015	9	27	04:50	UTC	73	18.04	N	160	47.07	W
MR15-03 NS40A-5	2015	10	3	22:55	UTC	65	04.11	N	168	38.80	W
MR15-03 NS40A-6	2015	10	9	22:57	UTC	54	13.76	N	164	09.76	W
MR15-03 NS40A-7	2015	10	17	00:08	UTC	43	48.08	N	159	58.10	E
MR15-03 NS40B-1	2015	8	26	11:18	UTC	40	28.23	N	142	00.71	E
MR15-03 NS40B-2	2015	9	6	22:32	UTC	67	44.65	N	168	45.31	W
MR15-03 NS40B-3	2015	9	18	01:35	UTC	72	17.76	N	155	15.39	W
MR15-03 NS40B-4	2015	9	27	04:50	UTC	73	18.04	N	160	47.07	W
MR15-03 NS40B-5	2015	10	3	22:55	UTC	65	04.11	N	168	38.80	W
MR15-03 NS40B-6	2015	10	9	22:57	UTC	54	13.76	N	164	09.76	W
MR15-03 NS40B-7	2015	10	17	00:08	UTC	43	48.08	N	159	58.10	E

Table 2.9-2: Summary of precipitation sampling for PFASs analysis

On board ID	Date Collected					Latitude			Longitude		
	YYYY	MM	DD	hh : mm	UTC/JST	Deg.	Min.	N/S	Deg.	Min.	E/W
MR15-03-R01	2015	9	7	04:29	UTC	68	19.16	N	168	45.48	W
MR15-03-R02	2015	9	18	01:35	UTC	72	17.76	N	155	15.39	W
MR15-03-R03	2015	9	27	02:50	UTC	73	18.04	N	160	47.07	W
MR15-03-R04	2015	9	28	14:21	UTC	73	53.20	N	166	09.95	W
MR15-03-R05	2015	10	3	22:55	UTC	65	04.11	N	168	38.80	W

(6) Data archives

These data obtained in this cruise will be submitted to the Data Management Group of JAMSTEC, and will be opened to the public via “Data Research System for Whole Cruise Information in JAMSTEC (DARWIN)” in JAMSTEC web site.

(7) References

- 1) Yamashita N, Kannan K, Taniyasu S, Horii Y, Okazawa T, Petrick G, Gamo T, Analysis of Perfluorinated Acids at Parts-Per-Quadrillion Levels in Seawater Using Liquid Chromatography-Tandem Mass Spectrometry, *Environ. Sci. Technol.* (2004) 38, 5522-5528
- 2) Taniyasu S, Kannan K, So MK, Gulkowskad A, Sinclair E, Okazawa T, Yamashita N, Analysis of fluorotelomer alcohols, fluorotelomer acids, and short- and long-chain perfluorinated acids in water and biota, *Journal of Chromatography A*, 1093 (2005) 89–97
- 3) ISO 25101 (2009 March 1st) Water quality — Determination of perfluorooctanesulfonate (PFOS) and perfluorooctanoate (PFOA) — Method for unfiltered samples using solid phase extraction and liquid chromatography/mass spectrometry

3. Physical Oceanography

3.1. CTD cast and water samplings

(1) Personnel

Shigeto Nishino*¹ (JAMSTEC): Principal Investigator

Tatsuya Tanaka*¹ (MWJ): Operation Leader

Shinsuke Toyoda*¹ (MWJ)

Rei Ito*¹ (MWJ)

Keisuke Takeda*² (MWJ)

*1: Leg1, Leg2

*2: Leg1

(2) Objectives

Investigation of oceanic structure and water sampling.

(3) Parameters

Temperature

Conductivity

Pressure

Dissolved Oxygen voltage

Dissolved Oxygen

Transmission %, beam attenuation coefficient and voltage

Fluorescence

Photosynthetically Active Radiation

Altimeter

(4) Instruments and methods

CTD/Carousel Water Sampling System, which is 36-position Carousel water sampler (CWS) with Sea-Bird Electronics, Inc. CTD (SBE9plus), was used during this cruise. 12-liter Niskin Bottles were used for sampling seawater. The sensors attached on the CTD were temperature (Primary and Secondary), conductivity (Primary and Secondary), pressure, dissolved oxygen voltage (RINKO III), dissolved oxygen (SBE43), transmission, fluorescence, PAR, deep ocean standards thermometer, and altimeter. The Practical Salinity was calculated by measured values of pressure, conductivity and temperature. The CTD/CWS was deployed from starboard on working deck.

The CTD raw data were acquired on real time using the Seasave-Win32 (ver.7.23.2) provided by Sea-Bird Electronics, Inc. and stored on the hard disk of the personal computer. Seawater was sampled during the up cast by sending fire commands from the personal computer. We stop at each layer for 1 minute above thermo cline or 30 seconds below thermo cline to stabilize then fire. 153 casts of CTD measurements were

conducted (Table 3.1-1). Data processing procedures and used utilities of SBE Data Processing-Win32 (ver.7.23.2.) and SEASOFT were as follows:

DATCNV: Convert the binary raw data to engineering unit data. DATCNV also extracts bottle information where scans were marked with the bottle confirm bit during acquisition. The duration was set to 4.4 seconds, and the offset was set to 0.0 seconds.

TCORP (original module): Corrected the pressure sensitivity of the primary temperature (SBE3) sensor.

S/N 031359: $-1.8386e-007$ (degC/dbar)

RINKOCOR (original module): Corrected the time dependent, pressure induced effect (hysteresis) of the RINKO for both profile data.

RINKOCORROS (original module): Corrected the time dependent, pressure induced effect (hysteresis) of the RINKO for bottle information data by using the hysteresis corrected profile data.

BOTTLESUM: Create a summary of the bottle data. The data were averaged over 4.4 seconds.

ALIGNCTD: Convert the time-sequence of sensor outputs into the pressure sequence to ensure that all calculations were made using measurements from the same parcel of water. Dissolved oxygen (SBE43) data are systematically delayed with respect to depth mainly because of the long time constant of the dissolved oxygen sensors and of an additional delay from the transit time of water in the pumped plumbing line. This delay was compensated by 6 seconds advancing dissolved oxygen sensors output (dissolved oxygen voltage) relative to the temperature data. RINKO-III voltage, transmission data and voltage are also delayed by slightly slow response time to the sensor. RINKO-III voltage was compensated by 1 second, and transmission data was compensated by 2 seconds advancing.

WILDEDIT: Mark extreme outliers in the data files. The first pass of WILDEDIT obtained an accurate estimate of the true standard deviation of the data. The data were read in blocks of 1000 scans. Data greater than 10 standard deviations were flagged. The second pass computed a standard deviation over the same 1000 scans excluding the flagged values. Values greater than 20 standard deviations were marked bad. This process was applied to pressure, depth, temperature, conductivity and dissolved oxygen (SBE43) voltage.

CELLTM: Remove conductivity cell thermal mass effects from the measured conductivity. Typical values used were thermal anomaly amplitude $\alpha = 0.03$ and the time constant $1/\beta = 7.0$.

FILTER: Perform a low pass filter on pressure with a time constant of 0.15 second. In order to produce zero phase lag (no time shift) the filter runs forward first then backward

WFILTER: Perform a median filter to remove spikes in the transmission data, voltage and fluorescence data. A median value was determined by 49 scans of the window.

SECTIONU (original module of SECTION): Select a time span of data based on scan number in order to reduce a file size. The minimum number was set to be the starting time when the CTD package was beneath the sea-surface after activation of the pump. The maximum number was set to be the end time when the package came up from the surface.

LOOPEDIT: Mark scans where the CTD was moving less than the minimum velocity of 0.0 m/s (traveling backwards due to ship roll).

DESPIKE (original module): Remove spikes of the data. A median and mean absolute deviation was calculated in 1-dbar pressure bins for both down and up cast, excluding the flagged values. Values greater than 4 mean absolute deviations from the median were marked bad for each bin. This process was performed twice for temperature, conductivity and dissolved oxygen (RINKO III and SBE43) voltage.

DERIVE: Compute dissolved oxygen (SBE43).

BINAVG: Average the data into 1-dbar pressure bins.

BOTTOMCUT (original module): Deletes discontinuous scan bottom data, if it's created by BINAVG.

DERIVE: Compute salinity, potential temperature, and σ -theta.

SPLIT: Separate the data from an input .cnv file into down cast and up cast files.

Configuration file

MR1503A.xmlcon: 001M001 - 098M002, 100M001 - 107M001

MR1503B.xmlcon: 099M001

MR1503C.xmlcon: 108M001 - 110M003

Specifications of the sensors are listed below.

CTD: SBE911plus CTD system

Under water unit:

SBE9plus (S/N 09P54451-1027, Sea-Bird Electronics, Inc.)

Pressure sensor: Digiquartz pressure sensor (S/N 117457)

Calibrated Date: 10 Apr. 2015

Used period: 001M001 - 107M001

SBE9plus (S/N 09P21746-0575, Sea-Bird Electronics, Inc.)

Pressure sensor: Digiquartz pressure sensor (S/N 79492)

Calibrated Date: 07 Apr. 2015

Used period: 108M001 - 110M003

Temperature sensors:

Primary: SBE03-04/F (S/N 031359, Sea-Bird Electronics, Inc.)

Calibrated Date: 01 May 2015

Secondary: SBE03-04/F (S/N 031525, Sea-Bird Electronics, Inc.)

Calibrated Date: 28 Jul. 2015

Conductivity sensors:

Primary: SBE04C (S/N 042435 Sea-Bird Electronics, Inc.)

Calibrated Date: 01 May 2015

Secondary: SBE04C (S/N 042854, Sea-Bird Electronics, Inc.)

Calibrated Date: 01 May 2015

Dissolved Oxygen sensors:

RINKO III (S/N 0024 (144002A), JFE Advantech Co., Ltd.)

Calibrated Date: 10 May 2015

RINKO III (S/N 037 (160005A), JFE Advantech Co., Ltd.)

Calibrated Date: 21 May 2015

SBE43 (S/N 430575, Sea-Bird Electronics, Inc.)

Calibrated Date: 06 May 2015

Transmissometer:

C-Star (S/N CST-1363DR, WET Labs, Inc.)

Calibrated Date: 28 Sep. 2014

Fluorescence:

Chlorophyll Fluorometer (S/N 2936, Seapoint Sensors, Inc.)

Chlorophyll Fluorometer (S/N 3618, Seapoint Sensors, Inc.)

Used period: 001M001 - 099M001

100M001 - 110M003

Photosynthetically Active Radiation:

PAR sensor (S/N 0049, Satlantic Inc.)

Calibrated Date: 22 Jan. 2009

Altimeter:

Benthos PSA-916T (S/N 1157, Teledyne Benthos, Inc.)

Deep Ocean Standards Thermometer:

SBE35 (S/N 0053, Sea-Bird Electronics, Inc.)

Calibrated Date: 13 May 2015

Carousel water sampler:

SBE32 (S/N 3221746-0278, Sea-Bird Electronics, Inc.)

Submersible Pump:

Primary: SBE5T (S/N 054598, Sea-Bird Electronics, Inc.)

Secondary: SBE5T (S/N 053293, Sea-Bird Electronics, Inc.)

Bottom contact switch: (Sea-Bird Electronics, Inc.)

Deck unit: SBE11plus (S/N 11P54451-0872, Sea-Bird Electronics, Inc.)

(5) Station list

During this cruise, 153 casts of CTD observation were carried out. Date, time and locations of the CTD casts are listed in Table 3.1-1. In some cast, we used a bottom contact sensor also.

(6) Preliminary results

During this cruise, we judged noise, spike or shift in the data of some cast. These were as follows.

002M001: Primary conductivity

down 44 dbar - up 4 dbar: shift

Dissolved oxygen (SBE43)

down 17 dbar - up surface: shift

005M001: Primary fluorescence

surface - down 14 dbar: range over

up 15 dbar - surface: range over

007M001: Primary fluorescence

surface - down 21 dbar: range over

up 20 dbar - surface: range over

022M001: Primary temperature and conductivity

up 26 dbar - up 9 dbar: shift

Dissolved oxygen (SBE43)
 down surface - up surface: shift
 Dissolved oxygen (secondary RINKO III)
 up 20 dbar - up surface: shift
 023M001: Dissolved oxygen (SBE43)
 down surface - up surface: shift
 023M002: Dissolved oxygen (SBE43)
 down surface - up surface: shift
 031M001: Secondary temperature and conductivity
 down 639 dbar - up 642 dbar: shift
 033M001: Primary conductivity
 up 78 dbar - up 47 dbar: shift
 051M001: Secondary conductivity
 up 124 dbar - up 29 dbar: shift
 053M002: Transmissonmeter
 down 52 dbar - down 57 dbar: spike
 053M009: Primary temperature and conductivity
 down 9 dbar : spike
 053M016: Secondary conductivity
 down 1472 dbar and down 1486 dbar : spike
 056M013: Primary salinity
 down 49 dbar : spike
 061M001: Primary temperature and conductivity
 down 665 dbar - down 666 dbar: spike
 Dissolved oxygen (SBE43)
 down 660 dbar - down 671 dbar: spike
 063M001: Primary conductivity
 down 439 dbar : spike
 066M001: Primary salinity
 down 159 dbar : spike
 068M001: Secondary fluorescence
 down surface - down 39 dbar: shift
 075M001: Secondary conductivity
 up 11 dbar – up 8 dbar: shift
 077M001: Secondary fluorescence
 down surface - down 69 dbar: shift
 up 18 dbar - up surface: shift
 082M001: Primary fluorescence
 down 127 dbar - down 128 dbar: spike

095M001: Primary temperature and conductivity
down 31 dbar: spike
Secondary fluorescence
down surface - down 50 dbar: shift

096M001: Secondary fluorescence
down surface - down 133 dbar: shift

097M001: Secondary fluorescence
down surface - down 69 dbar: shift

098M001: Secondary fluorescence
down surface - down 56 dbar: shift

098M002: Secondary fluorescence
down surface - down 49 dbar: shift
up 23 dbar - up surface: shift

099M001: Primary fluorescence
down 31 dbar - up 31 dbar: shift

100M001: Primary fluorescence
down 35 dbar - up 39 dbar: shift

101M001: Primary fluorescence
down 38 dbar - up 46 dbar: shift

103M001: Primary fluorescence
down surface - 35 dbar: range over
up 29 dbar - up surface: range over

110M001: Primary temperature and conductivity
down 36: spike

(7) Data archive

These data obtained in this cruise will be submitted to the Data Management Group of JAMSTEC, and will be opened to the public via "Data Research System for Whole Cruise Information in JAMSTEC (DARWIN)" in JAMSTEC web site.

<<http://www.godac.jamstec.go.jp/darwin/e>>

Table 3.1-1 MR15-03 CTD cast table

Stnnbr	Castno	Date(UTC)	Time(UTC)		BottomPosition		Depth	Wire Out	HT Above Bottom	Max Depth	Max Pressure	CTD Filename	Remark
		(mmddy)	Start	End	Latitude	Longitude							
001	1	090615	06:35	07:09	65-45.69N	168-45.19W	51.8	42.5	5.4	46.5	47.0	001M001	P.P. cast
002	1	090615	09:40	10:03	66-00.02N	168-45.26W	52.8	43.6	5.3	47.5	48.0	002M001	
003	1	090615	13:08	13:34	66-30.09N	168-45.58W	51.9	43.1	5.4	46.5	47.0	003M001	
004	1	090615	16:26	16:48	67-00.08N	168-44.99W	44.9	37.0	5.3	39.6	40.0	004M001	
005	1	090615	20:29	20:49	67-30.02N	168-45.12W	49.5	39.6	5.5	43.6	44.0	005M001	
006	1	090715	00:18	00:27	68-00.00N	168-45.11W	58.6	0.2	43.5	9.9	10.0	006M001	Hokkaido Univ. cast
006	2	090715	01:22	02:04	67-59.90N	168-46.64W	58.1	48.6	5.2	52.5	53.0	006M002	P.P. cast
007	1	090715	05:45	06:07	68-30.00N	168-45.10W	53.1	44.6	5.4	47.5	48.0	007M001	
008	1	090715	09:18	09:39	69-00.04N	168-44.86W	52.5	44.2	4.6	47.5	48.0	008M001	
009	1	090715	13:32	13:58	69-30.04N	168-44.91W	51.3	42.5	5.4	45.5	46.0	009M001	
010	1	090715	16:51	17:10	69-59.97N	168-44.98W	40.8	32.1	4.6	35.6	36.0	010M001	
011	1	090715	21:09	21:36	70-30.09N	168-45.13W	38.6	29.7	5.5	32.7	33.0	011M001	P.P. cast
012	1	090815	00:48	01:11	70-59.95N	168-45.12W	44.4	35.9	5.3	38.6	39.0	012M001	
013	1	090815	23:27	00:07	71-20.10N	157-39.87W	98.6	90.4	5.5	93.0	94.0	013M001	P.P. cast
014	1	090915	01:43	02:09	71-34.73N	157-50.25W	64.6	56.1	5.0	58.4	59.0	014M001	
015	1	090915	04:15	04:48	71-24.81N	157-30.04W	122.7	115.0	4.8	117.8	119.0	015M001	
016	1	090915	07:05	07:23	71-14.89N	157-09.66W	46.5	38.1	5.7	40.6	41.0	016M001	
017	1	090915	08:39	08:44	71-17.34N	157-15.02W	57.4	50.1	4.5	52.5	53.0	017M001	no water sampling
018	1	090915	09:17	09:22	71-19.84N	157-19.97W	90.6	82.7	5.2	85.1	86.0	018M001	no water sampling
019	1	090915	10:20	10:27	71-22.27N	157-25.02W	110.4	102.0	5.0	103.9	105.0	019M001	no water sampling
020	1	090915	11:18	11:26	71-27.27N	157-35.34W	110.2	102.0	5.2	104.9	106.0	020M001	no water sampling

021	1	090915	12:06	12:12	71-29.78N	157-40.64W	82.6	74.1	4.5	77.2	78.0	021M001	no water sampling
022	1	091115	15:08	15:30	71-35.99N	154-50.22W	42.0	33.2	5.3	36.6	37.0	022M001	
023	1	091115	17:33	18:21	71-44.44N	155-12.65W	307.0	319.6	3.4	304.6	308.0	023M001	
023	2	091115	20:09	20:40	71-46.41N	155-19.83W	186.0	94.3	-	99.9	101.0	023M002	P.P. cast
024	1	091115	22:14	22:39	71-52.67N	156-01.78W	81.1	66.6	5.7	74.2	75.0	024M001	
025	1	091215	00:47	01:14	71-49.50N	155-50.76W	88.5	73.0	8.4	79.2	80.0	025M001	
026	1	091215	03:13	03:45	71-48.26N	155-22.71W	149.3	142.7	6.6	146.4	148.0	026M001	
027	1	091215	06:29	06:56	71-39.95N	155-01.41W	104.0	94.4	4.9	99.9	101.0	027M001	
028	1	091215	15:48	16:13	72-00.06N	157-28.04W	78.6	69.0	4.4	74.2	75.0	028M001	
029	1	091215	18:10	18:38	72-07.94N	156-58.04W	131.0	117.2	9.0	121.7	123.0	029M001	
030	1	091215	20:04	20:50	72-17.37N	156-42.13W	272.0	258.0	7.8	261.1	264.0	030M001	
031	1	091315	18:07	19:31	72-06.21N	154-40.63W	1096.0	1075.6	9.5	1075.0	1089.0	031M001	
032	1	091315	21:53	23:07	71-59.99N	154-42.40W	1008.0	1000.6	8.7	1002.2	1015.0	032M001	
032	2	091415	00:59	01:34	72-00.19N	154-45.65W	786.0	96.3	-	99.0	100.0	032M002	P.P. cast
033	1	091415	02:30	03:12	71-55.03N	154-58.30W	334.0	319.8	8.3	323.4	327.0	033M001	
034	1	091415	05:22	05:47	71-44.16N	155-12.01W	306.0	95.9	-	99.0	100.0	034M001	Clean cast
034	2	091415	06:33	06:41	71-44.15N	155-12.03W	305.0	27.7	-	30.7	31.0	034M002	Clean cast
035	1	091415	08:48	09:19	72-01.31N	155-53.57W	148.3	141.4	5.0	143.5	145.0	035M001	
036	1	091415	10:38	10:48	72-06.24N	155-46.54W	230.8	219.1	5.8	222.6	225.0	036M001	no water sampling
037	1	091415	12:27	13:15	72-11.04N	155-39.07W	367.0	345.7	9.6	347.1	351.0	037M001	
038	1	091415	15:26	16:05	72-15.84N	155-31.94W	1056.0	1069.7	5.4	1059.3	1073.0	038M001	no water sampling
039	1	091415	21:56	22:33	72-23.48N	155-24.15W	1448.0	96.1	-	100.0	101.0	039M001	P.P. cast
039	2	091415	23:50	01:22	72-23.54N	155-28.00W	1350.0	1332.8	9.1	1334.8	1353.0	039M002	
040	1	091515	03:58	05:05	72-26.18N	156-35.45W	870.0	846.7	8.9	848.4	859.0	040M001	
041	1	091515	06:50	07:08	72-23.95N	156-35.82W	433.0	415.9	9.6	419.2	424.0	041M001	no water sampling
042	1	091515	08:43	08:58	72-21.74N	156-38.10W	342.0	331.4	6.4	333.3	337.0	042M001	no water sampling

043	1	091515	10:24	10:39	72-19.50N	156-40.09W	300.0	285.5	9.8	289.8	293.0	043M001	no water sampling
044	1	091515	12:20	12:33	72-17.33N	156-42.18W	269.0	257.5	6.1	261.1	264.0	044M001	no water sampling
045	1	091515	14:01	14:41	72-12.49N	156-50.64W	188.0	179.0	5.8	182.0	184.0	045M001	
046	1	091515	16:36	16:59	72-03.91N	157-13.19W	88.0	74.5	8.9	79.2	80.0	046M001	
047	1	091515	19:03	19:28	71-57.09N	158-00.06W	65.8	51.9	8.6	56.4	57.0	047M001	P.P. cast
048	1	091515	21:20	21:45	72-08.32N	157-23.33W	76.2	65.8	5.8	69.3	70.0	048M001	
049	1	091515	23:18	23:40	72-00.06N	156-53.65W	95.2	81.1	9.3	85.1	86.0	049M001	
050	1	091615	00:53	01:26	72-05.08N	156-25.93W	149.0	138.3	5.9	142.5	144.0	050M001	
051	1	091615	02:23	03:06	72-11.44N	156-12.79W	253.9	244.5	9.7	246.3	249.0	051M001	
052	1	091615	04:12	05:36	72-20.20N	156-10.51W	1076.0	1049.3	9.9	1048.4	1062.0	052M001	
053	1	091615	11:49	12:07	72-20.27N	155-22.81W	1616.0	500.6	-	500.2	506.0	053M001	no water sampling
053	2	091615	15:01	15:23	72-20.39N	155-23.01W	1618.0	498.6	-	500.2	506.0	053M002	no water sampling
053	3	091615	17:53	18:13	72-20.38N	155-23.38W	1607.0	498.3	-	500.2	506.0	053M003	no water sampling
053	4	091615	19:45	20:49	72-20.42N	155-23.49W	1619.0	499.7	-	502.2	508.0	053M004	P.P. cast
053	5	091615	23:50	00:09	72-20.26N	155-22.71W	1622.0	495.9	-	500.2	506.0	053M005	no water sampling
053	6	091715	02:51	03:13	72-20.44N	155-23.09W	1625.0	498.8	-	501.2	507.0	053M006	no water sampling
053	7	091715	05:50	06:11	72-20.55N	155-23.12W	1632.0	498.3	-	500.2	506.0	053M007	no water sampling
053	8	091715	07:48	08:29	72-20.37N	155-23.10W	1617.0	501.4	-	500.2	506.0	053M008	
053	9	091715	11:48	12:06	72-20.48N	155-22.94W	1631.0	498.8	-	500.2	506.0	053M009	no water sampling
053	10	091715	14:59	15:20	72-20.50N	155-22.86W	1627.0	499.9	-	500.2	506.0	053M010	no water sampling
053	11	091715	17:52	18:12	72-20.70N	155-23.51W	1662.0	501.6	-	501.2	507.0	053M011	no water sampling
053	12	091715	19:29	20:54	72-21.32N	155-23.56W	1682.0	1665.0	10.1	1664.9	1689.0	053M012	
053	13	091715	23:51	00:09	72-20.41N	155-23.45W	1611.0	499.2	-	500.2	506.0	053M013	no water sampling
053	14	091815	02:55	03:15	72-20.56N	155-23.36W	1631.0	498.8	-	500.2	506.0	053M014	no water sampling
053	15	091815	05:50	06:10	72-20.59N	155-23.54W	1636.0	498.4	-	500.2	506.0	053M015	no water sampling
053	16	091815	07:46	09:16	72-20.50N	155-23.50W	1626.0	1606.6	8.3	1606.0	1629.0	053M016	

054	1	091815	19:17	19:52	72-28.36N	155-24.08W	2004.0	97.7	-	99.9	101.0	054M001	P.P. cast
054	2	091815	20:44	22:26	72-28.25N	155-23.47W	1998.0	1985.5	8.5	1975.9	2006.0	054M002	
054	3	091915	03:37	04:24	72-28.98N	155-24.13W	2074.0	797.7	-	793.2	803.0	054M003	Cs cast
055	1	091915	19:45	20:45	72-22.93N	155-59.76W	1375.0	498.6	-	500.2	506.0	055M001	P.P. cast
056	1	091915	23:50	00:08	72-16.81N	155-59.35W	748.0	499.4	-	500.2	506.0	056M001	no water sampling
056	2	092015	02:51	03:11	72-16.65N	155-58.39W	651.0	498.3	-	500.2	506.0	056M002	no water sampling
056	3	092015	05:48	06:09	72-17.78N	155-59.17W	964.0	497.7	-	500.2	506.0	056M003	no water sampling
056	4	092015	07:47	08:28	72-16.29N	155-57.29W	444.0	411.9	10.4	414.3	419.0	056M004	
056	5	092015	11:48	12:06	72-16.85N	155-58.49W	662.0	499.0	-	500.2	506.0	056M005	no water sampling
056	6	092015	14:54	15:14	72-16.77N	155-57.97W	575.0	500.6	-	502.2	508.0	056M006	no water sampling
056	7	092015	17:49	18:09	72-16.73N	155-58.59W	694.0	498.3	-	500.2	506.0	056M007	no water sampling
056	8	092015	19:33	20:29	72-17.55N	156-01.64W	917.0	502.1	-	502.2	508.0	056M008	P.P. cast
056	9	092015	23:49	00:07	72-16.80N	155-58.83W	721.0	498.4	-	500.2	506.0	056M009	no water sampling
056	10	092115	02:32	03:15	72-16.94N	155-59.36W	789.0	498.6	-	500.2	506.0	056M010	
056	11	092115	05:50	06:11	72-16.89N	155-59.16W	758.0	498.1	-	500.2	506.0	056M011	no water sampling
056	12	092115	07:45	08:30	72-16.77N	155-58.53W	679.0	593.3	-	594.0	601.0	056M012	
056	13	092115	11:47	12:05	72-16.98N	155-58.88W	755.0	498.6	-	500.2	506.0	056M013	no water sampling
056	14	092115	14:53	15:14	72-17.03N	155-58.78W	750.0	500.1	-	500.2	506.0	056M014	no water sampling
056	15	092115	17:51	18:12	72-16.94N	155-59.54W	779.0	501.0	-	501.2	507.0	056M015	no water sampling
056	16	092115	19:47	20:34	72-16.90N	155-59.09W	761.0	498.3	-	500.2	506.0	056M016	
056	17	092115	23:48	00:06	72-16.79N	156-00.12W	683.0	499.9	-	500.2	506.0	056M017	no water sampling
057	1	092215	04:30	05:06	71-59.92N	154-41.96W	1020.0	1003.9	8.6	1007.1	1020.0	057M001	no water sampling
058	1	092215	06:08	06:48	72-06.29N	154-40.62W	1090.0	1098.5	8.0	1097.7	1112.0	058M001	no water sampling
059	1	092215	07:36	08:23	72-12.42N	154-38.65W	1394.0	1369.2	10.0	1369.2	1388.0	059M001	no water sampling
060	1	092215	10:29	12:13	72-11.15N	153-33.50W	2110.0	2098.3	9.3	2095.5	2128.0	060M001	
061	1	092215	13:47	15:24	72-01.29N	153-50.65W	1537.0	1537.7	6.2	1541.2	1563.0	061M001	

062	1	092215	16:46	17:20	71-49.93N	153-49.47W	176.0	160.5	8.7	163.3	165.0	062M001	
062	2	092215	18:47	19:17	71-49.93N	153-48.98W	173.0	97.2	-	99.9	101.0	062M002	P.P. cast
063	1	092315	06:03	07:09	72-22.25N	155-31.12W	1302.0	1278.2	9.1	1280.7	1298.0	063M001	
064	1	092315	09:43	10:34	72-15.87N	155-57.94W	424.0	402.7	10.1	404.4	409.0	064M001	
065	1	092315	13:00	13:40	72-11.67N	156-15.49W	258.0	248.7	6.5	251.2	254.0	065M001	
066	1	092315	15:52	16:36	72-15.98N	156-24.88W	398.0	385.5	9.5	388.6	393.0	066M001	
067	1	092315	21:06	21:49	72-10.05N	155-30.91W	380.0	359.6	9.2	361.9	366.0	067M001	
068	1	092415	00:18	01:06	72-10.47N	156-13.45W	242.0	228.3	9.8	232.5	235.0	068M001	P.P. cast
069	1	092415	02:38	03:14	72-10.07N	155-52.48W	274.0	266.1	6.2	270.0	273.0	069M001	
070	1	092415	05:54	06:33	72-10.05N	156-40.72W	188.0	176.2	4.6	182.0	184.0	070M001	
071	1	092415	08:18	08:47	72-10.07N	157-11.24W	113.0	103.6	6.0	107.9	109.0	071M001	
072	1	092415	14:24	14:46	72-34.87N	159-41.40W	54.9	40.2	7.2	47.5	48.0	072M001	
073	1	092415	15:52	15:58	72-41.06N	159-24.44W	76.0	64.2	9.4	70.3	71.0	073M001	no water sampling
074	1	092415	17:10	17:51	72-46.81N	159-06.01W	183.0	174.6	14.4	179.1	181.0	074M001	
075	1	092415	22:27	00:39	73-12.53N	157-48.22W	2595.0	2590.0	8.6	2565.2	2608.0	075M001	P.P. cast
076	1	092515	03:29	04:18	73-00.09N	158-30.55W	1334.0	1299.1	-	1304.3	1322.0	076M001	no water sampling
077	1	092515	05:37	06:30	72-53.23N	158-48.04W	362.0	342.0	9.3	348.1	352.0	077M001	
078	1	092515	10:57	11:02	72-47.96N	161-24.10W	49.0	41.1	5.5	43.5	44.0	078M001	no water sampling
079	1	092515	13:02	13:10	73-01.48N	161-15.00W	139.0	128.6	5.0	131.6	133.0	079M001	no water sampling
080	1	092515	15:09	15:26	73-17.97N	160-47.69W	422.0	411.0	8.9	413.3	418.0	080M001	no water sampling
081	1	092515	17:28	18:18	73-12.82N	161-15.81W	371.0	362.4	5.9	364.9	369.0	081M001	
082	1	092515	21:19	22:13	73-08.15N	162-17.91W	201.0	189.8	8.5	195.9	198.0	082M001	P.P. cast
083	1	092615	01:30	01:55	73-03.57N	163-38.23W	106.0	89.3	9.5	94.0	95.0	083M001	
084	1	092615	04:25	04:49	73-03.47N	164-36.11W	75.0	62.9	5.0	69.3	70.0	084M001	
085	1	092615	17:22	17:56	73-18.30N	160-46.74W	428.0	96.3	-	100.9	102.0	085M001	P.P. cast
085	2	092615	18:51	19:45	73-18.61N	160-45.60W	437.0	422.2	8.6	428.1	433.0	085M002	

086	1	092715	05:01	05:07	72-58.74N	161-11.92W	91.0	82.0	5.7	85.1	86.0	086M001	no water sampling
087	1	092715	06:43	06:53	73-06.68N	161-35.37W	198.0	191.6	4.2	194.9	197.0	087M001	no water sampling
088	1	092715	08:33	08:41	73-14.65N	161-58.72W	171.0	163.4	4.3	166.2	168.0	088M001	no water sampling
089	1	092715	10:41	10:49	73-22.48N	162-22.02W	138.0	126.9	5.1	129.6	131.0	089M001	no water sampling
090	1	092715	12:38	12:46	73-30.41N	162-46.02W	153.0	143.6	6.4	145.4	147.0	090M001	no water sampling
091	1	092715	14:41	14:48	73-19.84N	163-04.01W	93.0	85.6	4.8	89.1	90.0	091M001	no water sampling
092	1	092715	16:31	16:41	73-29.28N	162-14.59W	171.0	162.5	6.1	165.2	167.0	092M001	no water sampling
093	1	092715	18:54	19:07	73-30.26N	161-23.61W	274.0	263.0	8.5	265.1	268.0	093M001	no water sampling
094	1	092715	21:38	23:12	73-28.52N	160-08.16W	1615.0	1585.4	9.8	1584.3	1607.0	094M001	P.P. cast
095	1	092815	10:46	11:10	73-34.07N	165-56.20W	103.0	94.1	4.9	97.0	98.0	095M001	
096	1	092815	13:16	13:49	73-53.19N	166-09.95W	153.0	141.6	5.4	144.4	146.0	096M001	
097	1	092815	15:45	15:56	74-11.67N	166-24.91W	244.0	233.3	5.1	235.4	238.0	097M001	no water sampling
098	1	092815	18:03	18:39	74-27.70N	166-38.13W	314.0	95.7	-	99.9	101.0	098M001	P.P. cast
098	2	092815	19:32	20:26	74-27.76N	166-37.02W	316.0	300.8	8.5	306.6	310.0	098M002	
099	1	092915	00:12	00:48	74-30.02N	168-45.11W	194.0	180.8	7.7	185.0	187.0	099M001	
100	1	092915	04:36	05:08	74-00.00N	168-45.29W	181.0	170.4	5.3	174.1	176.0	100M001	
101	1	092915	09:18	09:44	73-29.92N	168-45.37W	120.0	106.0	4.8	109.8	111.0	101M001	
102	1	092915	22:24	22:54	72-00.10N	168-44.74W	51.0	45.1	5.0	50.5	51.0	102M001	P.P. cast
103	1	093015	02:31	02:50	71-30.00N	168-44.98W	48.7	40.0	5.3	44.5	45.0	103M001	
104	1	093015	06:19	06:37	70-59.92N	168-44.80W	45.0	37.0	4.5	39.6	40.0	104M001	
105	1	093015	09:42	10:00	70-29.96N	168-45.13W	38.0	29.0	4.5	33.7	34.0	105M001	
106	1	100115	00:05	00:25	67-59.90N	168-44.82W	58.0	44.7	8.7	49.5	50.0	106M001	
107	1	100115	03:59	04:19	68-29.93N	168-45.01W	54.0	44.4	5.2	48.5	49.0	107M001	
108	1	100315	09:17	09:41	67-00.02N	168-44.89W	45.0	37.2	4.6	40.6	41.0	108M001	P.P. cast
109	1	100315	15:59	16:21	66-00.12N	168-45.04W	52.5	42.5	8.3	44.6	45.0	109M001	
110	1	101415	18:34	19:21	45-46.02N	166-28.45E	5940.0	1183.8	-	1187.7	1201.0	110M001	RMNS cast

110	2	101415	21:04	21:52	45-46.48N	166-28.22E	5890.0	1187.1	-	1189.7	1203.0	110M002	RMNS cast
110	3	101415	23:24	00:12	45-47.93N	166-29.65E	5798.0	1191.3	-	1191.7	1205.0	110M003	RMNS cast

3.2. XCTD

(1) Personnel

Shigeto Nishino	JAMSTEC: PI	Leg1, Leg2
Yusuke Kawaguchi	JAMSTEC	Leg1, Leg2
Hiroki Takeda	JAMSTEC / Tokyo Gakugei University	Leg1, Leg2
Shinya Okumura	GODI	Leg1
Wataru Tokunaga	GODI	Leg1
Koichi Inagaki	GODI	Leg1
Souichiro Sueyoshi	GODI	Leg2
Yutaro Murakami	GODI	Leg1, Leg2
Masanori Murakami	MIRAI Crew	Leg1, Leg2

(2) Objective

To obtain vertical profiles of sea water temperature and salinity (calculated by the function of temperature, pressure (depth), and conductivity).

(3) Parameters

The range and accuracy of parameters measured by the XCTD (eXpendable Conductivity, Temperature & Depth profiler) are as follows;

Parameter	Range	Accuracy
Conductivity	0 ~ 60 [mS/cm]	+/- 0.03 [mS/cm]
Temperature	-2 ~ 35 [deg-C]	+/- 0.02 [deg-C]
Depth	0 ~ 1000 [m]	5 [m] or 2 [%] (either of them is major)

(4) Instruments and Methods

We observed the vertical profiles of the sea water temperature and conductivity measured by XCTD-1 manufactured by Tsurumi-Seiki Co.(TSK). The signal was converted by MK-150N(TSK), and was recorded by AL-12B software (Ver.1.1.4, TSK). We launched 82 probes (XCTD-01 – XCTD-83) by using automatic launcher. The summary of XCTD observation log is shown in Table 3.2-1.

(5) Observation log

Table 3.2-1: XCTD observation log

No.	Station No.	Date [YYYY/MM/DD]	Time [hh:mm]	Latitude [degN]	Longitude [degW]	Depth [m]	SST [deg-C]	SSS [PSU]	Probe S/N
1	XCTD-01	2015/09/09	20:36	71-43.7880	155-06.5876	236	4.377	30.164	12057537
2	XCTD-02	2015/09/10	05:53	71-44.0111	154-48.7901	134	4.800	30.686	12057575
3	XCTD-03	2015/09/10	06:18	71-48.0415	154-37.5447	163	5.945	30.978	12057566
4	XCTD-04	2015/09/10	06:36	71-50.2450	154-31.0149	171	6.380	31.009	12057565
5	XCTD-05	2015/09/11	04:00	71-51.0636	154-35.1414	188	5.286	30.620	12057564
6	XCTD-06	2015/09/11	04:30	71-53.8033	154-52.7877	388	3.422	29.538	12057567

No.	Station No.	Date [YYYY/MM/DD]	Time [hh:mm]	Latitude [degN]	Longitude [degW]	Depth [m]	SST [deg-C]	SSS [PSU]	Probe S/N
7	XCTD-07	2015/09/11	05:00	71-55.1155	155-11.6796	242	4.418	30.243	12057568
8	XCTD-08	2015/09/11	05:30	71-54.1190	155-28.8776	168	4.018	30.067	12057569
9	XCTD-09	2015/09/11	06:00	71-55.0226	155-45.5321	116	3.902	30.347	12057570
10	XCTD-10	2015/09/11	06:30	71-56.8924	156-03.0854	81	5.437	30.955	12057571
11	XCTD-11	2015/09/12	22:42	72-28.5390	156-24.6456	1195	0.752	27.808	12057574
12	XCTD-12	2015/09/12	23:09	72-28.6461	156-15.8980	1231	0.519	27.563	12057584
13	XCTD-13	2015/09/12	23:39	72-29.0494	156-06.9068	1702	1.423	27.744	12057538
14	XCTD-14	2015/09/13	00:10	72-29.3295	155-53.5588	1506	1.175	27.230	12057582
15	XCTD-15	2015/09/13	00:36	72-27.8979	155-47.8610	1552	0.258	25.909	12057587
16	XCTD-16	2015/09/13	01:09	72-24.9395	155-43.7255	1606	-0.240	25.408	12057581
17	XCTD-17	2015/09/13	01:40	72-23.0914	155-35.1596	1359	-0.589	24.825	12057586
18	XCTD-18	2015/09/13	02:09	72-20.4899	155-23.3451	1623	-0.592	25.180	12057583
19	XCTD-19	2015/09/13	02:40	72-17.5611	155-11.4600	1462	0.316	25.611	12057585
20	XCTD-20	2015/09/13	03:10	72-15.2701	154-57.7833	1524	0.766	26.166	12057539
21	XCTD-21	2015/09/13	03:40	72-15.0417	154-42.3005	1971	1.014	26.499	12057572
22	XCTD-22	2015/09/13	04:10	72-15.0952	154-26.0432	1973	1.641	26.496	12057573
23	XCTD-23	2015/09/13	05:02	72-10.3830	154-30.2983	1479	1.536	27.009	13010557
24	XCTD-24	2015/09/13	05:03	72-10.7752	154-45.1213	1518	1.588	26.670	13010554
25	XCTD-25	2015/09/13	06:00	72-10.9858	155-02.4698	1024	1.675	26.387	13010556
26	XCTD-26	2015/09/13	06:36	72-14.2887	155-23.3959	839	1.383	27.006	12057576
27	XCTD-27	2015/09/13	06:53	72-17.3065	155-23.4207	1383	0.637	26.142	12057577
28	XCTD-28	2015/09/13	07:30	72-17.9026	155-34.4065	1267	0.380	25.720	12057579
29	XCTD-29	2015/09/13	08:00	72-17.9524	155-54.6061	856	0.766	26.978	12057578
30	XCTD-30	2015/09/13	08:30	72-17.9863	156-15.1858	789	2.684	28.975	12057580
31	XCTD-31	2015/09/13	09:00	72-17.8385	156-35.3339	330	2.521	30.374	13010552
32	XCTD-32	2015/09/13	09:10	72-17.8881	156-42.6294	272	3.854	30.436	13010553
33	XCTD-33	2015/09/13	09:34	72-15.0034	156-41.4890	250	4.203	30.369	13010555
34	XCTD-34	2015/09/13	09:54	72-11.4740	156-41.2573	211	4.197	30.560	15062409
35	XCTD-35	2015/09/13	10:30	72-11.5306	156-29.4065	255	4.487	30.634	15062410
36	XCTD-36	2015/09/13	11:00	72-11.5434	156-12.7303	258	4.167	30.357	15062411
37	XCTD-37	2015/09/13	11:30	72-11.0694	155-59.0047	272	1.598	29.008	15062412
38	XCTD-38	2015/09/13	12:00	72-11.3001	155-45.7454	328	1.928	28.410	15062413
39	XCTD-39	2015/09/13	12:30	72-11.4997	155-29.6618	479	1.889	27.516	15062414
40	XCTD-40	2015/09/13	12:41	72-11.5016	155-23.3260	696	1.762	27.081	15062415
41	XCTD-41	2015/09/13	13:00	72-10.5819	155-14.5323	842	1.824	26.671	15062416
42	XCTD-42	2015/09/13	13:30	72-08.5960	154-59.7956	948	1.705	26.759	15062417
43	XCTD-43	2015/09/13	14:00	72-06.6120	154-44.2020	937	1.739	26.682	15062418
44	XCTD-44	2015/09/15	02:23	72-23.3788	155-40.8380	1450	1.100	26.867	15062455
45	XCTD-45	2015/09/15	02:49	72-24.4450	155-58.7920	1359	0.686	25.837	15062448
46	XCTD-46	2015/09/15	03:20	72-25.4670	156-19.0464	1166	1.146	26.467	15062449
47	XCTD-47	2015/09/16	07:56	72-23.4167	155-23.3035	1520	1.474	27.132	13010549
48	XCTD-48	2015/09/16	08:20	72-20.4408	155-23.3068	1626	1.388	27.008	13010550
49	XCTD-49	2015/09/16	08:38	72-17.4410	155-23.3542	1405	1.418	26.988	13010546
50	XCTD-50	2015/09/16	13:32	72-20.4629	155-11.6809	1482	1.132	26.867	13010547
51	XCTD-51	2015/09/16	13:51	72-20.4888	155-00.0430	1951	1.190	27.151	15062419

No.	Station No.	Date [YYYY/MM/DD]	Time [hh:mm]	Latitude [degN]	Longitude [degW]	Depth [m]	SST [deg-C]	SSS [PSU]	Probe S/N
52	XCTD-52	2015/09/17	01:29	72-17.8739	155-15.7898	1339	1.381	27.000	15062420
53	XCTD-53	2015/09/17	01:49	72-15.3033	155-08.2687	1466	1.212	27.064	13010548
54	XCTD-54	2015/09/17	13:27	72-20.4637	155-11.7371	1461	0.975	26.990	13010551
55	XCTD-55	2015/09/17	13:45	72-20.4257	155-00.0912	1948	0.836	26.691	15062446
56	XCTD-56	2015/09/18	01:34	72-17.8558	155-15.6993	1342	0.969	27.189	15062450
57	XCTD-57	2015/09/18	01:53	72-15.2544	155-08.3124	1461	0.831	27.325	15062447
58	XCTD-58	2015/09/19	13:22	72-10.9941	155-48.0621	305	1.541	28.838	15062451
59	XCTD-59	2015/09/19	13:52	72-14.2023	155-47.8180	418	0.817	27.365	15062452
60	XCTD-60	2015/09/19	14:22	72-17.3899	155-47.7358	847	0.962	27.496	15062453
61	XCTD-61	2015/09/19	14:52	72-20.2377	155-51.7152	1204	0.907	27.353	15062454
62	XCTD-62	2015/09/19	15:22	72-22.7877	155-58.7535	1409	0.677	27.169	15062455
63	XCTD-63	2015/09/19	15:52	72-25.3360	156-05.3360	1584	0.957	27.091	15062456
64	XCTD-64	2015/09/19	16:22	72-27.7651	156-11.9501	1518	0.557	26.944	15073031
65	XCTD-65	2015/09/23	02:32	72-22.1428	156-41.9467	324	0.429	25.907	15031474
66	XCTD-66	2015/09/23	02:48	72-20.0458	156-34.9517	365	0.092	25.781	15031458
67	XCTD-67	2015/09/23	03:08	72-17.9981	156-28.9912	415	0.522	25.967	15031460
68	XCTD-68	2015/09/23	03:16	72-15.8991	155-24.4850	398	0.493	26.155	15031456
69	XCTD-69	2015/09/23	03:29	72-13.7933	156-19.9676	353	0.216	26.081	15031457
70	XCTD-70	2015/09/23	03:42	72-11.6984	156-15.1102	257	0.557	27.227	15073034
71	XCTD-71	2015/09/23	04:17	72-13.7999	156-06.5778	310	0.466	27.189	15073532
72	XCTD-72	2015/09/23	04:35	72-15.8998	155-57.5403	413	0.489	26.000	15073030
73	XCTD-73	2015/09/23	04:54	72-18.0038	155-48.3126	614	0.464	25.915	15073033
74	XCTD-74	2015/09/23	05:11	72-20.1033	155-39.8603	1164	0.010	25.756	15073035
75	XCTD-75	2015/09/23	18:30	72-10.0206	156-42.0004	186	0.334	26.204	15073029
76	XCTD-76	2015/09/23	18:46	72-10.0245	156-32.1916	216	0.331	26.626	15031455
77	XCTD-77	2015/09/23	19:02	72-10.0200	156-22.5008	235	0.177	27.147	15031459
78	XCTD-78	2015/09/23	19:19	72-10.0585	156-12.6193	238	0.229	27.283	15031461
79	XCTD-79	2015/09/23	19:35	72-10.1219	156-02.8616	247	0.330	27.312	15073026
80	XCTD-80	2015/09/23	19:51	72-10.0514	155-52.8577	269	0.222	26.752	15073025
81	XCTD-81	2015/09/23	20:07	72-09.9915	155-43.2586	305	0.201	26.806	15073024
82	XCTD-82	2015/09/23	20:23	72-10.0339	155-33.4810	362	1.266	29.033	15073027
83	XCTD-83	2015/10/16	05:32	44-49.4395	-196-52.1588	5534	13.582	33.028	15073028

SST : Sea Surface Temperature [deg-C] measured by TSG (ThermoSalinoGraph).

SSS : Sea Surface Salinity [PSU] measured by TSG.

(6) Data archives

These data obtained in this cruise will be submitted to the Data Management Group of JAMSTEC, and will be opened to the public via “Data Research System for Whole Cruise Information in JAMSTEC (DARWIN)” in JAMSTEC web site.

<<http://www.godac.jamstec.go.jp/darwin/e>>

3.3. Underway CTD

(1) Personnel

Yusuke Kawaguchi	(JAMSTEC): Principal investigator
Shigeto Nishino	(JAMSTEC)
Amane Fujiwara	(JAMSTEC)
Hiroki Takeda	(JAMSTEC)
Motoyo Itho	(JAMSTEC)
Shinsuke Toyoda	(MWJ): Operation leader
Keisuke Matsumoto	(MWJ)
Rei Ito	(MWJ)
Keisuke Takeda	(MWJ)

(2) Objective

The “Underway CTD” (U-CTD) system collects vertical profiles of temperature, conductivity and pressure of seawater as the traditional CTD system can do. The apparent advantages for using the U-CTD system are that it assures a certain accuracy of CTD data even under an operation of ship’s sailing. The U-CTD system is believed to provide more accurate data than those from an expendable type of CTD equipment (X-CTD; see Section 3.4) because of well-calibrated, quality-proven sensors carried on it (see Table 3.3-1 for nominal specification of each sensor).

Main objective of the U-CTD observation during the present cruise is to obtain a series of CTD profiles in the Canada Basin area of the Arctic Ocean partly instead of the use of the X-CTD.

(3) Methods

The U-CTD system, manufactured by *Ocean Science Group*, was utilized in this cruise. The system consists of two separate parts: probe unit, and on-deck unit with a power winch and a rewinding system, as in a photo (Figure 3.3-1). The probe unit is physically connected to the power winch onboard with a 300/500 lb fabric line. With the line winded a certain length onto the probe unit (called “tail spool”), the probe is dropped from the stern deck into the ocean so that it can measure temperature, conductivity, and pressure of seawater while free-falling at a descending rate of roughly 4 m s^{-1} . Releasing the line from the tail spool ensure the probe unit to fall down without any artificial force on the line (and consequently minimize a noise corruption on the raw data), even under the ship’s sailing. Once the probe reached the depth needed for the

observation, it is recovered by using the winch installed on the lower stern deck. The obtained data are stored in a memory device inside the probe unit. Then, it is immediately downloaded into a PC via a Bluetooth communication system after the probe is on the deck.

Table 3.3-1 gives a brief summary of manufacturer’s nominal specification for each sensor on the U-CTD system. The system used can get temperature, conductivity and pressure at the depths from surface to 500 m with a 16-Hz sampling rate. In this occasion, the expected time until when the sensor probe reaches the greatest depth of 500m is approximately 135 seconds. We thus intended to let the probe down for another 30 seconds so that the sensors can fully accomplish their falling. This procedure could minimize electronic loads imposed on the winch as rewinding the line up at a fast speed.

During the acquisition of hydro data, the ship’s sailing goes on with a moderate speed and heading being straightforward. The manufacturer also gives a table of combination of maximum ship speed and observational depth for the vertical profiling (Table 3.3-2). Throughout the overall U-CTD operation during this cruise, the ship’s travelling speed was controlled to be nearly 7 knot (nautical miles per hour).

In operating the U-CTD system, we faced multiple technical/mechanical problems in the cold weather in the Arctic. A part of those issues are noted in the end of this report.

Table 3.3-1: Specification of CTD sensors equipped with the U-CTD system.

Parameter	Accuracy	Resolution	Range
Temperature (°C)	0.004	0.002	-5 to 43
Conductivity (S/m)	0.0003	0.0005	0 to 9
Pressure (dbar)	1.0	0.5	0 to 2000

Table 3.3-2: A summary of observation depth and maximum ship speed under U-CTD operation.

Maximum depth to profile	Maximum ship speed (knot)
0 to 350 m	13
350 to 400 m	12
400 to 450 m	11
450 to 500 m	10
500 to 550 m	8
550 to 600 m	6
600 to 650 m	4
650 to 1000 m	2



Figure 3.3-1: A whole set of U-CTD system installed on a lower stern deck of R/V Mirai.

(4) Preliminary Results

During this cruise, 7 casts of U-CTD observation were performed. Exact information of date/time and geographical positions of those casts are overviewed in Table 3.3-3.

Vertical profiles (down cast) of temperature, conductivity, salinity and descending rate are shown in Figure 3.3-2. The temperature profile shows the highest peak around the depth of 50–80 dbar (corresponding to $S \sim 31.0$ psu), which we consider the relatively new, Pacific-origin water lately intruded on this isohaline surface via the Barrow Canyon. As a result, it can also be found a massive-scale temperature fluctuation of 2–3 °C over a 20 m vertical depth. Underneath this warm intrusive layer, hydrographic properties are rather typical in the Pacific-side Arctic: a cold Pacific water with temperature being -1.5 – -1.4 °C on a $S = 32.5$ – 33.0 isohaline surface, and underlying, Atlantic-origin water with temperature peaked at a 250-dbar level. Density field generally shows a statically stable structure, except a bunch of small-scale density inversion at depths of the warm Pacific water layer, perhaps implying convective overturning cells. The details of the warm Pacific water intrusion were explored by using a turbulent instrument, TurboMAP, during the same cruise (see Section 3.6).

Here is a brief note about a technical issue that we faced in dealing with the instrument under a low temperature environment. It actually happened in the middle of StnU007 (see Table 3.3-3 for the detailed information), when the dropped sensor already reached the greatest depth of 500 m and then about to be recovered. As reeling up the line at the fast mode as usual, the electric power to the winch abruptly turned down. It was however fortunate that the power was regained in minutes, after many times of trial and error on the deck, although the power supply barely worked and seemed interrupted occasionally yet. During handling this problem, we learned that

starting with a slow mode for the winch operation could be very effective to wake up the dead winch to work again. What we should note here is that the soaking wet fabric line, linking the winch and probe, can be easily frozen as soon as exposed to the cold air. Here is details of the operational environment at the recovery: air temperature -2.5°C , sea surface temperature 1.7°C , and ship speed roughly 7.6 knot. At that time, we saw chunks of $\sim 1\text{-m}$ thick ice floes only sparsely floating around.

(5) Data archive

The entire dataset made by U-CTD observation during this cruise will be submitted to the Data Management Group of JAMSTEC, and will be opened to the public via “Data Research System for Whole Cruise Information in JAMSTEC (DARWIN)” via a JAMSTEC web site below.

<<http://www.godac.jamstec.go.jp/darwin/e>>

Table 3.3-3: A list of U-CTD stations during MR15-03 cruise

Station Number	Cast Number	Time Towed (UTC)	Position Towed		Depth to go (m)	Ship speed (knot)		S/N of sensor	Notes
			Lat. (deg-min)	Lon. (deg-min)		Tow	Recovery		
U001	1	2015/09/12 22:19	72-28.83N	156-29.51W	500	7	7	0249	
U002	1	2015/09/14 17:56	72-17.53N	155-23.32W	500	7	7	0246	
U003	1	2015/09/14 18:25	72-20.52N	155-23.35W	500	7	7	0249	
U004	1	2015/09/14 18:54	72-23.51N	155-23.34W	500	7	7	0247	
U005	1	2015/09/14 19:23	72-26.49N	155-23.32W	500	7	7	0249	
U006	1	2015/09/14 20:15	72-29.34N	155-23.58W	500	7	7	0247	
U007	1	2015/9/16 07:31	72-26.43N	155-23.33W	500	7	7	0249	Electric power down at recovery. See a note in (4).

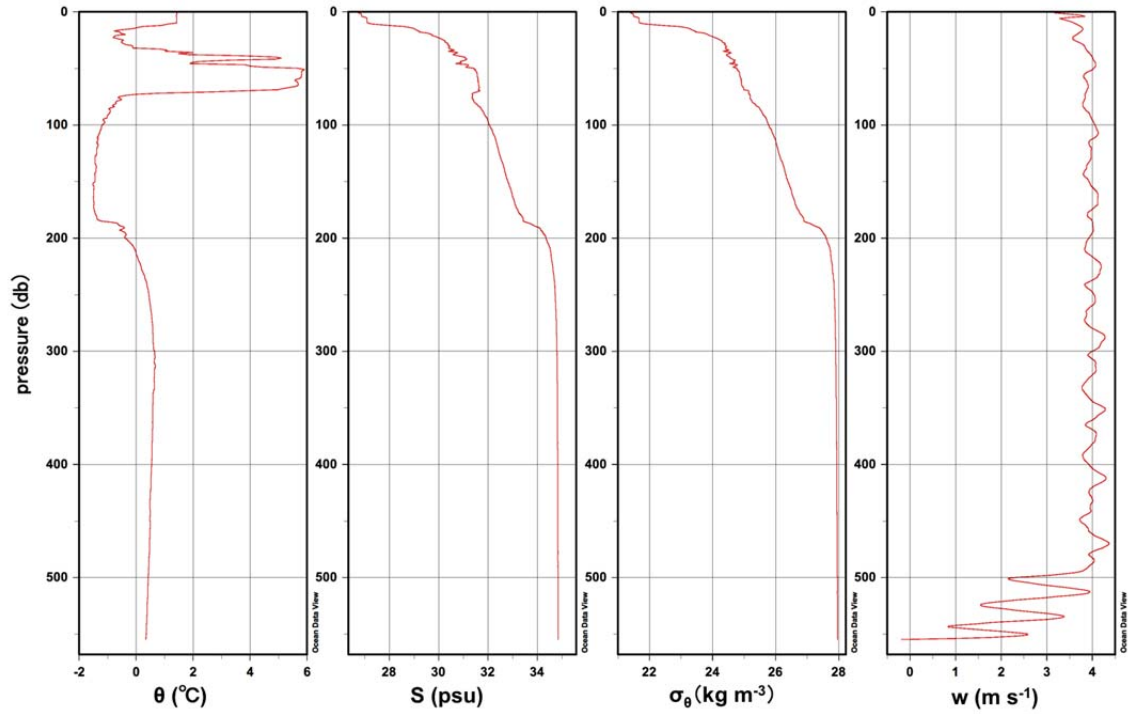

Figure 3.3-2: Typical profiles from U-CTD observation of (a) potential temperature θ (deg-C), (b) salinity S (practical salinity unit), (c) potential density σ_θ (kg m^{-3}), and (d) descending rate w (m s^{-1}) at a station of u003c01, positioned off the Barrow Canyon.

3.4. Shipboard ADCP

(1) Personnel

Shigeto Nishino	JAMSTEC: PI
Yusuke Kawaguchi	JAMSTEC
Hiroki Takeda	JAMSTEC / Tokyo Gakugei University
Shinya Okumura	GODI
Wataru Tokunaga	GODI
Koichi Inagaki	GODI
Yutaro Murakami	GODI
Masanori Murakami	MIRAI Crew

(2) Objectives

To obtain continuous measurement data of the current profile along the ship's track.

(3) Parameters

Major parameters for the measurement, Direct Command, are shown in Table 3.4-1.

Table 3.4-1: Major parameters

Bottom-Track Commands	
BP = 001	Pings per Ensemble (almost less than 1,200m depth)
Environmental Sensor Commands	
EA = 04500	Heading Alignment (1/100 deg)
ED = 00065	Transducer Depth (0 - 65535 dm)
EF = +001	Pitch/Roll Divisor/Multiplier (pos/neg) [1/99 - 99]
EH = 00000	Heading (1/100 deg)
ES = 35	Salinity (0-40 pp thousand)
EX = 00000	Coordinate Transform (Xform:Type; Tilts; 3Bm; Map)
EZ = 10200010	Sensor Source (C; D; H; P; R; S; T; U)
	C (1): Sound velocity calculates using ED, ES, ET (temp.)
	D (0): Manual ED
	H (2): External synchro
	P (0), R (0): Manual EP, ER (0 degree)
	S (0): Manual ES
	T (1): Internal transducer sensor
	U (0): Manual EU
EV = 0	Heading Bias(1/100 deg)
Timing Commands	
TE = 00:00:02.00	Time per Ensemble (hrs:min:sec.sec/100)
TP = 00:02.00	Time per Ping (min:sec.sec/100)
Water-Track Commands	
WA = 255	False Target Threshold (Max) (0-255 count)

WC = 120	Low Correlation Threshold (0-255)
WD = 111 100 000	Data Out (V; C; A; PG; St; Vsum; Vsum ² ; #G; P0)
WE = 1000	Error Velocity Threshold (0-5000 mm/s)
WF = 0800	Blank After Transmit (cm)
WN = 100	Number of depth cells (1-128)
WP = 00001	Pings per Ensemble (0-16384)
WS = 800	Depth Cell Size (cm)
WV = 0390	Mode 1 Ambiguity Velocity (cm/s radial)

(4) Instruments and methods

Upper ocean current measurements were made in this cruise, using the hull-mounted Acoustic Doppler Current Profiler (ADCP) system. For most of its operation, the instrument was configured for water-tracking mode. Bottom-tracking mode, interleaved bottom-ping with water-ping, was made to get the calibration data for evaluating transducer misalignment angle in the shallow water. The system consists of following components:

1. R/V MIRAI has installed the Ocean Surveyor for vessel-mount ADCP (frequency 76.8 kHz; Teledyne RD Instruments, USA). It has a phased-array transducer with single ceramic assembly and creates 4 acoustic beams electronically. We mounted the transducer head rotated to a ship-relative angle of 45 degrees azimuth from the keel
2. For heading source, we use ship's gyro compass (Tokyo Keiki, Japan), continuously providing heading to the ADCP system directory. Additionally, we have Inertial Navigation System (Phins, Ixblue, France) which provide high-precision heading, attitude information, pitch and roll. They are stored in ".N2R" data files with a time stamp.
3. Differential GNSS system (StarPack-D, Fugro, Netherlands) providing precise ship's position.
4. We used VmDas software version 1.46.5 (TRDI) for data acquisition.
5. To synchronize time stamp of ping with Computer time, the clock of the logging computer is adjusted to GPS time server every 1 minute.
6. Fresh water is charged in the sea chest to prevent bio fouling at transducer face.
7. The sound speed at the transducer does affect the vertical bin mapping and vertical velocity measurement, and that is calculated from temperature, salinity (constant value; 35.0 PSU) and depth (6.5 m; transducer depth) by equation in Medwin (1975).

Data was configured for "8 m" intervals starting about 23 m below sea surface. Data was recorded every ping as raw ensemble data (.ENR). Also, 30 or 60 seconds and 300 seconds averaged data were recorded as short-term average (.STA) and long-term average (.LTA) data, respectively.

(5)Observation Period

23 Aug. 2015 – 20 Sep. 2015 (UTC)

(6)Remarks

Shipboard ADCP observation was terminated on 20 Sep, because hardware trouble was occurred to the system.

(7)Data archives

These data obtained in this cruise will be submitted to the Data Management Group of JAMSTEC, and will be opened to the public via “Data Research System for Whole Cruise Information in JAMSTEC (DARWIN)” in JAMSTEC web site.

<<http://www.godac.jamstec.go.jp/darwin/e>>

3.5. Microstructure observations

(1) Personnel

Yusuke Kawaguchi (JAMSTEC): Principal investigator
 Hiroki Takeda (JAMSTEC / Tokyo Gakugei University)
 Shinya Okumura (GODI): Operation leader
 Wataru Tokunaga (GODI)
 Koich Inagaki (GODI)
 Yutaro Murakami (GODI)
 Masanori Murakami (Mirai Crew)

(2) Objectives and methodology

To understand turbulent mixing and diapycnal heat transfer in the ice-free region of the Western Arctic Ocean, microscale temperature and vertical shear data were acquired during MR15-03. Total number of the TurboMAP observation is 266.

(3) Parameters

According to the manufacture's nominal specifications, sensing range, accuracy and sampling rate of parameters are shown in Table 3.5-1.

Table 3.5-1: Detail lists of sensors.

Parameter	Type	Range	Accuracy	Sampling rate
$\partial u/\partial z$ (primary)	Shear probe	0~10 /s	5%	512 Hz
$T+\partial T/\partial z$	FPO-7 thermistor	-5~45°C	$\pm 0.01^\circ\text{C}$	512 Hz
Temperature (T)	Platinum wire thermometer	-5~45°C	$\pm 0.01^\circ\text{C}$	64 Hz
Conductivity	Inductive Cell	0~70 mS	± 0.01 mS	64 Hz
Depth	Semiconductor strain gauge	0~1000 m	$\pm 0.2\%$	64 Hz
x- acceleration	Solid-state fixed mass	± 2 G	$\pm 1\%$	256 Hz
y- acceleration	Solid-state fixed mass	± 2 G	$\pm 1\%$	256 Hz
z- acceleration	Solid-state fixed mass	± 2 G	$\pm 1\%$	64Hz

Chlorophyll	Fluorescence	0~100 $\mu\text{g/Lm}$	0.5 $\mu\text{g/L}$ or $\pm 1\%$	256 Hz
Turbidity	Backscatter	0~100 ppm	1ppm or $\pm 2\%$	256 Hz
$\partial u/\partial z$ (Secondary)	Shear probe	0~10 s^{-1}	5%	512 Hz

(4) Instruments and methodology

Turbulence Ocean Microstructure Acquisition Profiler (TurboMAP-L, built by Alec Electronics Co Ltd.) was used to measure turbulence-scale temperature and current shear. The TurboMAP is a loosely tethered quasi-free-fall profiler that is equipped with two airfoil shear probes, a fast-response thermistor (FP07), a light-emitting diode fluorescence/turbidity probe, and a CTD package (Wolk et al. 2002). The TurboMAP collects vertical profiles of microscale velocity shear, high- and low-resolution temperature, conductivity, and pressure, as the underwater device descends from the surface to maximum depth (~450 m). The descending rate of underwater device is roughly at 0.5–0.6 m s^{-1} . Operation of the ship’s side thrusters was usually halted while the data acquisition is on-going so that they may not create any artificial noise corruption in the micro-scale data. The data obtained within 7 m depth are not recommended for the use of scientific analysis as they may include potential noise corruption due to the initial adjustment to the free-falling or/and due to effects of pitching/rolling ship motion.

(5) Station list

The operational information of all TurboMAP observations is listed in Table 3.5-2.

(6) Preliminary results

Throughout the series of TurboMAP observations, we focused on a warm water intrusion and turbulent mixing around a distinct structure of a cyclonic eddy (also refer to Section 3.6). Figure 3.5-1 shows an intriguing pattern in vertical temperature that was found at an upper depth of the oceanic cyclone. The figure demonstrates that the temperature profile consists of a bunch of 1–5 m scale bumps, with a remarkable structure of staircases at top and bottom of each temperature maxima. That is, every corner of temperature change accompanies very sharp gradient. This is considered as a direct consequence of the horizontal interleaving, where the different water masses laterally intrude with each other, and then creates such intricate pattern from vertical convective cells due to the double-diffusive mixing. This is perhaps the same phenomenon that was already reported during the past *Mirai* cruise, surveying a huge-sized, warm anticyclonic eddy (Kawaguchi et al. 2012).

Reference

Wolk et al., “A new free-fall profiler for measuring biophysical microstructure”, *J. Atmos. Ocean. Tech.*, **19**, 780–793, 2002.

Kawaguchi et al., “A detailed survey of a large baroclinic eddy with extremely high temperature in the Western Canada Basin”, *Deep-Sea Research I*, **60**, 90–102, 2012.

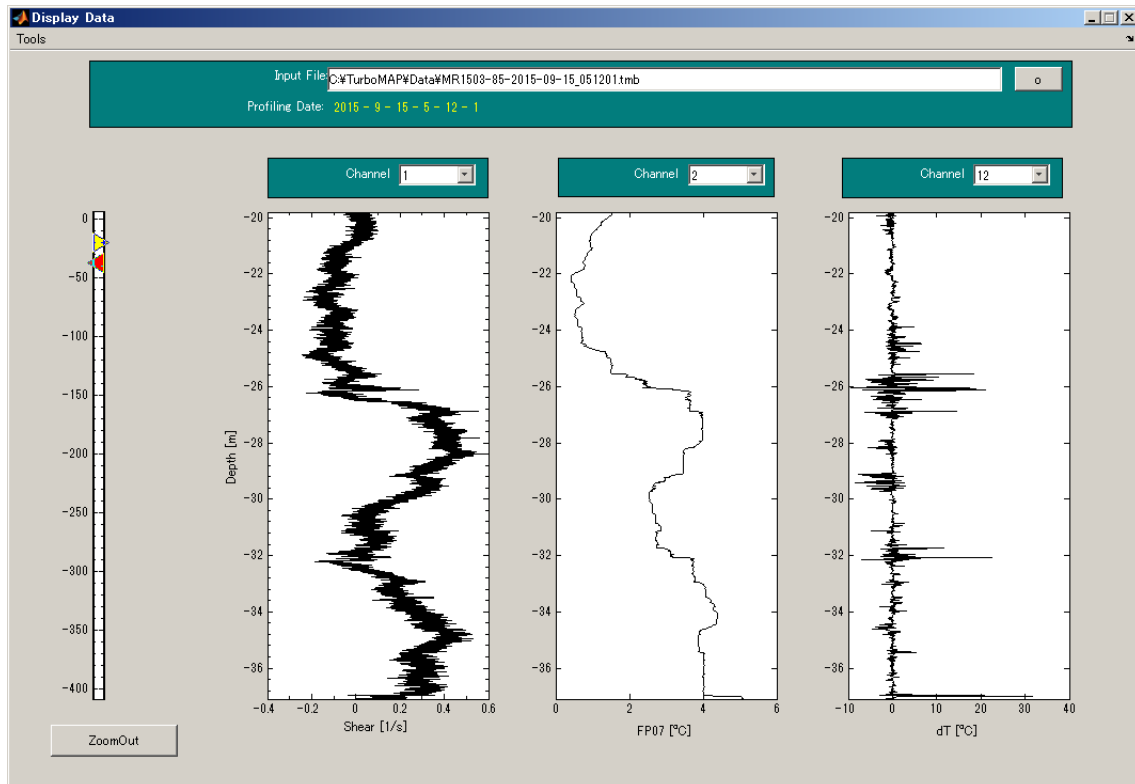

Figure 3.5-1: Vertical profiles of current shear, high-frequency temperature by FPO7, and vertical gradient of FPO7 temperature. The data were taken at (72-26.53°N, 156-36.01°W) at 05:12UTC September 15. A screen capture of a software *TMTools* (JFE Advantech Co Ltd.).

Table 3.5-2: Observation log.

No.	Date [YYYY/MM/DD]	Latitude [deg-min]	Longitude [deg-min]	Logging Time		Depth [m]	Obs. Depth [m]	Sensor S/N		
				Start	Stop			FPO7	Shear 1	Shear 2
01	2015/09/01	50-07.4947N	166-07.2245E	1:19	1:37	5359	625	144	505	504
02	2015/09/01	50-07.0676N	166-07.4072E	2:12	2:19	-	244	144	505	504
03	2015/09/01	50-06.6481N	166-07.8910E	2:51	2:59	5369	256	147	503	1232
04	2015/09/02	52-45.3331N	170-55.5963E	1:08	1:19	2903	335	147	503	1232
05	2015/09/02	52-44.9303N	170-56.3909E	1:46	1:57	3096	338	144	505	504
06	2015/09/02	52-44.5058N	170-57.0416E	2:31	2:43	3289	372	236	1233	1234
07	2015/09/06	65-45.7798N	168-45.6247W	7:24	7:25	51	41	144	503	505
08	2015/09/06	65-45.8093N	168-45.6252W	7:28	7:29	51	39	144	503	505
09	2015/09/06	65-45.8096N	168-45.6418W	7:31	7:32	51	35	144	503	505
10	2015/09/06	67-00.1103N	168-45.01W	17:01	17:04	45	33	144	503	505
11	2015/09/06	67-00.1139N	168-45.0473W	17:05	17:07	45	40	144	503	505
12	2015/09/06	67-00.1066N	168-45.0573W	17:08	17:10	45	37	144	503	505
13	2015/09/06	67-30.0368N	168-45.2644W	20:55	20:58	49	37	144	503	505
14	2015/09/06	67-30.0497N	168-45.2889W	20:59	21:02	49	37	144	503	505
15	2015/09/06	67-30.0614N	168-45.3489W	21:02	21:05	49	44	144	503	505
16	2015/09/06	67-59.9811N	168-45.8258W	0:47	0:56	58	53	144	503	505
17	2015/09/06	67-59.9693N	168-45.9230W	0:56	0:59	58	50	144	503	505
18	2015/09/06	67-59.9818N	168-45.8143W	1:00	1:02	58	51	144	503	505
19	2015/09/07	68-30.09N	168-46.03W	6:17	6:18	53	46	144	503	505
20	2015/09/07	68-30.10N	168-46.14W	6:19	6:20	53	48	144	503	505
21	2015/09/07	68-30.11N	168-46.21W	6:22	6:23	53	47	144	503	505
22	2015/09/07	68-59.98N	168-45.21W	9:49	9:51	52	46	144	503	505
23	2015/09/07	68-59.98N	168-45.28W	9:52	9:53	52	43	144	503	505
24	2015/09/07	68-59.98N	168-45.34W	9:55	9:56	52	-	144	503	505
25	2015/09/07	68-59.98N	168-45.38W	9:59	10:00	52	47	144	503	505
26	2015/09/07	69-59.8788N	168-45.0121W	17:17	17:20	40	34	144	503	505
27	2015/09/07	69-59.8739N	168-45.0437W	17:21	17:22	40	33	144	503	505
28	2015/09/07	69-59.8689N	168-45.0852W	17:23	17:25	40	35	144	503	505
29	2015/09/08	70-59.7530N	168-45.0983W	1:20	1:23	44	38	144	503	505
30	2015/09/08	70-59.8436N	168-45.1190W	1:24	1:25	44	38	144	503	505
31	2015/09/08	70-59.8347N	168-45.1485W	1:26	1:28	44	39	144	503	505
32	2015/09/09	71-34.36N	157-50.05W	2:19	2:21	64	54	144	503	505

33	2015/09/09	71-34.75N	157-50.05W	2:23	2:25	64	55	144	503	505
34	2015/09/09	71-34.73N	157-49.55W	2:26	2:29	64	55	144	503	505
35	2015/09/09	71-24.82N	157-30.30W	4:56	4:59	122	118	144	503	505
36	2015/09/09	71-24.86N	157-30.36W	5:03	5:05	122	106	144	503	505
37	2015/09/09	71-24.91N	157-30.38W	5:09	5:11	122	109	144	503	505
38	2015/09/09	71-14.98N	157-09.74W	7:32	7:35	47	38	144	503	505
39	2015/09/09	71-14.99N	157-09.75W	7:35	7:36	47	42	144	503	505
40	2015/09/09	71-15.00N	157-09.75W	7:37	7:39	47	42	144	503	505
41	2015/09/09	71-19.90N	157-20.04W	9:29	9:34	91	84	144	503	505
42	2015/09/09	71-19.91N	157-20.10W	9:34	9:37	91	81	144	503	505
43	2015/09/09	71-19.92N	157-20.18W	9:39	9:42	91	85	144	503	505
44	2015/09/09	71-29.83N	157-41.19W	12:21	12:25	83	65	144	503	505
45	2015/09/09	71-29.83N	157-41.37W	12:28	12:29	83	65	144	503	505
46	2015/09/09	71-29.87N	157-41.56W	12:31	12:35	83	69	144	503	505
47	2015/09/11	71-36.39N	154-51.04W	15:36	15:39	41	28	144	503	505
48	2015/09/11	71-36.48N	154-51.20W	15:40	15:42	41	34	144	503	505
49	2015/09/11	71-36.44N	154-51.08W	15:43	15:44	41	33	144	503	505
50	2015/09/11	71-45.16N	155-15.08W	18:28	18:34	242	163	144	503	505
51	2015/09/11	71-45.30N	155-15.63W	18:41	18:46	227	170	144	503	505
52	2015/09/11	71-45.50N	155-15.79W	18:55	19:03	216	175	144	503	505
53	2015/09/11	71-53.03N	156-02.27W	22:47	22:51	80	68	144	503	505
54	2015/09/11	71-53.11N	156-02.47W	22:53	22:57	80	69	144	503	505
55	2015/09/11	71-53.17N	156-02.70W	22:59	23:02	80	72	144	503	505
56	2015/09/11	71-49.85N	155-52.04W	1:24	1:28	88	60	144	503	505
57	2015/09/11	71-49.89N	155-52.23W	1:29	2:32	88	70	144	503	505
58	2015/09/11	71-49.94N	155-52.54W	1:34	1:38	88	74	144	503	505
59	2015/09/12	71-48.73N	155-23.69W	3:52	3:57	157	102	144	503	505
60	2015/09/12	71-48.88N	155-23.96W	3:59	4:05	-	125	144	503	505
61	2015/09/12	71-49.04N	155-24.30W	4:10	4:14	-	113	144	503	505
62	2015/09/12	71-49.22N	155-24.63W	4:19	4:25	-	137	144	503	505
63	2015/09/12	71-40.02N	155-03.24W	7:03	7:07	112	80	144	503	505
64	2015/09/12	71-40.07N	155-03.82W	7:10	7:13	-	86	144	503	505
65	2015/09/12	-	-	-	-	-	109	144	503	505
66	2015/09/12	71-40.09N	155-04.59W	7:24	7:28	118	87	144	503	505
67	2015/09/13	72-06.5231N	154-41.4858W	19:38	19:55	1080	520	144	503	505
68	2015/09/13	72-06.7472N	154-42.4924W	20:06	20:21	998	548	144	503	505

69	2015/09/13	71-59.9530N	154-42.9041W	23:14	23:31	1017	561	144	503	505
70	2015/09/13	72-00.0801N	154-43.7112W	23:43	0:00	965	576	144	503	505
71	2015/09/14	71-55.0517N	154-58.9938W	3:18	3:27	321	313	144	503	505
72	2015/09/14	71-55.0925N	154-59.8821W	3:42	3:49	321	253	144	503	505
73	2015/09/14	72-01.49N	155-53.88W	9:27	9:33	148	129	144	503	505
74	2015/09/14	72-01.51N	155-51.93W	9:36	9:40	148	132	144	503	505
75	2015/09/14	72-01.54N	155-53.94W	9:43	9:47	148	132	144	503	505
76	2015/09/14	72-06.4053N	155-46.972W	10:59	11:04	228	151	144	503	505
77	2015/09/14	72-06.5349N	155-47.4175W	11:09	11:14	228	164	144	503	505
78	2015/09/14	72-06.6855N	155-47.9514W	11:20	11:26	228	195	144	503	505
79	2015/09/14	72-11.4832N	155-40.6854W	13:25	13:37	363	334	144	503	505
80	2015/09/14	72-11.7048N	155-41.5286W	13:46	13:56	363	330	144	503	505
81	2015/09/14	72-15.9735N	155-32.7490W	16:12	16:26	1018	433	144	503	505
82	2015/09/14	72-16.1755N	155-34.1515W	16:39	16:52	1018	431	144	503	505
83	2015/09/14	72-23.5225N	155-25.0882W	22:40	22:54	1305	440	144	503	505
84	2015/09/14	72-23.5478N	155-26.2021W	23:07	23:21	1305	477	144	503	505
85	2015/09/15	72-26.5303N	156-36.0081W	5:11	5:26	867	433	144	503	505
86	2015/09/15	72-26.9912N	156-37.4334W	5:41	5:54	867	436	144	503	505
87	2015/09/15	72-24.1351N	156-36.4834W	7:17	7:25	447	283	144	503	505
88	2015/09/15	72-24.4515N	156-37.5957W	7:34	7:44	447	309	144	503	505
89	2015/09/15	72-21.9200N	156-38.5499W	9:05	9:18	346	332	144	503	505
90	2015/09/15	72-22.1943N	156-39.4434W	9:24	9:34	346	315	144	503	505
91	2015/09/15	72-19.6294N	156-40.5397W	10:46	10:56	301	272	144	503	505
92	2015/09/15	72-19.7908N	156-41.0919W	11:02	11:10	301	262	144	503	505
93	2015/09/15	72-17.4020N	156-42.6733W	12:41	12:50	266	241	144	503	505
94	2015/09/15	72-17.4876N	156-43.0861W	12:54	13:03	266	231	144	503	505
95	2015/09/15	72-12.5907N	156-51.3475W	14:49	14:56	186	170	144	503	505
96	2015/09/15	72-12.6343N	156-51.5237W	15:00	15:06	187	180	144	503	505
97	2015/09/15	72-12.6484N	156-51.7630W	15:10	15:15	188	150	144	503	505
98	2015/09/16	72-20.2737N	155-22.9773W	12:15	12:28	1619	428	144	503	505
99	2015/09/16	72-20.2745N	155-23.0031W	12:39	12:53	1619	452	144	503	505
100	2015/09/16	72-20.3298N	155-22.8797W	15:30	15:45	1619	462	144	503	505
101	2015/09/16	72-20.3313N	155-22.9573W	15:55	16:09	1619	443	144	503	505
102	2015/09/16	72-29.3818N	155-23.5159W	18:20	18:34	1607	449	144	503	505
103	2015/09/16	72-20.3623N	155-23.6020W	18:45	18:59	1607	438	144	503	505
104	2015/09/16	72-20.4496N	155-23.5538W	20:55	21:09	1620	443	144	503	505

105	2015/09/16	72-20.5033N	155-23.5858W	21:21	21:34	1620	428	144	503	505
106	2015/09/17	72-20.2859N	155-22.7217W	0:17	0:31	1623	459	144	503	505
107	2015/09/17	72-20.3692N	155-22.3323W	0:41	0:51	1623	445	144	503	505
108	2015/09/17	72-20.4612N	155-22.7897W	3:19	3:34	1628	454	144	1234	505
109	2015/09/17	72-20.5585N	155-22.2986W	3:42	3:56	1628	456	144	1234	505
110	2015/09/17	72-20.5582N	155-22.5406W	6:17	6:17	1631	478	144	1234	505
111	2015/09/17	-	-	-	-	-	-	144	1234	505
112	2015/09/17	72-20.6254N	155-22.3819W	6:41	6:54	1631	446	144	1234	505
113	2015/09/17	72-20.3885N	155-21.5904W	8:36	8:51	1693	498	144	1234	505
114	2015/09/17	72-20.5378N	155-20.9630W	9:01	9:15	1693	454	144	1234	505
115	2015/09/17	72-20.6270N	155-22.7179W	12:14	12:28	1641	434	144	1234	505
116	2015/09/17	72-20.8358N	155-22.4396W	12:38	12:51	1641	453	144	1234	505
117	2015/09/17	72-20.5724N	155-22.9621W	15:27	15:41	1633	462	144	1234	505
118	2015/09/17	72-20.7488N	155-22.7791W	15:52	16:05	1633	458	144	1234	505
119	2015/09/17	72-20.7977N	155-23.8073W	18:19	18:34	1684	478	144	1234	505
120	2015/09/17	72-21.0499N	155-23.5445W	18:44	18:57	1684	432	144	1234	505
121	2015/09/17	72-21.5001N	155-23.7954W	21:00	21:14	1641	437	144	1234	505
122	2015/09/17	72-21.6004N	155-24.0513W	21:25	21:38	1641	429	144	1234	505
123	2015/09/18	72-20.5237N	155-23.5206W	0:17	0:31	1628	430	144	1234	505
124	2015/09/18	72-20.7487N	155-23.8428W	0:39	0:52	1628	438	144	1234	505
125	2015/09/18	-	-	3:22	3:24	-	-	144	1234	505
126	2015/09/18	72-20.7495N	155-23.1912W	3:26	3:29	1662	116	144	1234	505
127	2015/09/18	72-20.8659N	155-23.2534W	3:32	3:45	1662	445	144	1234	505
128	2015/09/18	72-21.1943N	155-23.4349W	3:55	4:08	1662	442	144	1234	505
129	2015/09/18	72-20.7363N	155-73.5774W	6:17	6:30	1670	429	144	1234	505
130	2015/09/18	72-20.9287N	155-23.7855W	6:40	6:52	1680	434	144	1234	505
131	2015/09/18	72-20.9971N	155-23.8691W	9:22	9:36	1680	477	144	1234	505
132	2015/09/18	72-21.3363N	155-24.3765W	9:52	10:05	1680	413	144	1234	505
133	2015/09/19	72-22.8642N	156-00.9274W	20:52	21:07	1299	461	144	1234	505
134	2015/09/19	72-22.8427N	156-01.8978W	21:17	21:30	1299	430	144	1234	505
135	2015/09/20	72-16.8365N	155-59.3717W	0:15	0:30	754	450	144	1234	505
136	2015/09/20	72-16.8287N	155-59.5971W	0:38	0:51	754	461	144	1234	505
137	2015/09/20	72-16.5840N	155-58.3080W	3:18	3:32	623	436	144	1234	505
138	2015/09/20	72-16.5300N	155-58.6402W	3:41	3:54	623	432	144	1234	505
139	2015/09/20	72-17.8094N	155-59.2377W	6:15	6:30	966	459	144	1232	505
140	2015/09/20	72-17.3877N	155-59.3189W	6:39	6:52	966	465	144	1232	505

141	2015/09/20	72-16.4452N	155-57.5338W	8:35	8:48	486	417	144	1232	505
142	2015/09/20	72-16.5686N	155-57.9721W	8:56	9:10	486	427	144	1232	505
143	2015/09/20	72-16.9163N	155-58.6534W	12:15	12:29	664	466	144	1232	505
144	2015/09/20	72-17.0038N	155-59.4274W	12:40	12:54	664	455	144	1232	505
145	2015/09/20	72-16.7912N	155-58.0375W	15:21	15:36	576	456	144	1232	505
146	2015/09/20	72-16.9237N	155-58.5774W	15:45	15:59	576	445	144	1232	505
147	2015/09/20	72-16.8456N	155-58.6622W	18:15	18:30	694	455	144	1232	505
148	2015/09/20	72-17.0733N	155-59.2484W	18:39	18:52	694	435	144	1232	505
149	2015/09/20	72-17.4719N	156-02.8828W	20:35	20:50	813	444	144	1232	505
150	2015/09/20	72-17.5453N	156-03.7537W	20:59	21:12	813	437	144	1232	505
151	2015/09/21	72-17.8741N	155-59.1041W	0:14	0:29	815	466	144	1232	505
152	2015/09/21	72-17.0702N	155-59.4885W	0:37	0:50	815	449	144	1232	505
153	2015/09/21	72-17.1341N	156-00.2558W	3:23	3:37	769	451	144	1232	505
154	2015/09/21	72-17.3502N	156-00.7182W	3:46	3:59	769	439	144	1232	505
155	2015/09/21	72-16.9966N	155-59.5336W	6:18	6:31	777	429	144	1232	505
156	2015/09/21	72-17.2323N	155-59.9994W	6:41	6:54	777	442	144	1232	505
157	2015/09/21	72-17.0149N	155-59.1064W	8:36	8:51	784	443	144	1232	505
158	2015/09/21	72-17.1825N	155-59.5545W	9:00	9:14	784	451	144	1232	505
159	2015/09/21	72-17.0572N	155-59.2041W	12:12	12:26	804	456	144	1232	505
160	2015/09/21	72-17.2083N	155-59.4743W	12:35	12:49	849	457	144	1232	505
161	2015/09/21	72-17.1671N	155-58.8302W	15:21	15:35	793	436	144	1232	505
162	2015/09/21	72-17.6357N	155-59.3961W	15:44	15:57	793	442	144	1232	505
163	2015/09/21	72-17.0764N	155-59.6853W	18:19	18:33	796	443	144	1232	505
164	2015/09/21	72-17.2705N	156-00.0575W	18:42	18:55	796	434	144	1232	505
165	2015/09/21	72-16.9795N	155-59.5518W	20:41	20:55	789	444	144	1232	505
166	2015/09/21	72-17.2707N	156-00.0577W	21:05	21:17	789	422	144	1232	505
167	2015/09/22	72-16.9060N	156-00.4608W	0:12	0:25	697	427	144	1232	505
168	2015/09/22	72-17.0884N	156-01.0423W	0:35	0:47	697	435	144	1232	505
169	2015/09/22	72-49.8626N	153-48.2731W	17:32	17:38	171	146	144	1232	505
170	2015/09/22	72-49.9021N	153-47.8997W	17:41	17:46	171	146	144	1232	505
171	2015/09/22	72-49.9307N	153-47.4507W	17:49	17:54	171	145	144	1232	505
172	2015/09/23	72-22.3829N	155-31.2104W	7:17	7:26	1294	279	144	1232	505
173	2015/09/23	72-22.3177N	155-31.2812W	7:31	7:41	1294	280	144	1232	505
174	2015/09/23	72-18.0005N	155-48.4991W	8:36	8:46	630	284	144	1232	505
175	2015/09/23	72-17.9545N	155-48.6780w	8:50	8:59	630	283	144	1232	505
176	2015/09/23	72-15.8723N	155-59.0278W	10:41	10:51	420	279	144	1232	505

177	2015/09/23	72-15.7644N	155-59.3328W	10:57	11:05	420	273	144	1232	505
178	2015/09/23	72-13.7261N	156-06.9881W	11:47	11:56	311	274	144	1232	505
179	2015/09/23	72-13.6887N	156-07.4879W	12:06	12:15	311	279	144	1232	505
180	2015/09/23	72-11.5876N	156-16.4934W	13:47	13:55	258	210	144	1232	505
181	2015/09/23	72-11.5863N	156-16.8516W	14:00	14:06	258	205	144	1232	505
182	2015/09/23	72-13.8210N	156-20.1748W	14:59	15:08	360	274	144	1232	505
183	2015/09/23	72-13.8849N	156-20.9852W	14:59	15:08	360	281	144	1232	505
184	2015/09/23	72-16.1924N	156-25.1116W	16:42	16:52	406	276	144	1232	505
185	2015/09/23	72-16.3005N	156-25.2824W	16:58	17:08	406	282	144	1232	505
186	2015/09/23	72-10.0866N	155-30.2937W	21:55	22:05	381	268	144	1232	505
187	2015/09/23	72-10.1710N	155-30.0767W	22:12	22:21	381	272	144	1232	505
188	2015/09/24	72-10.3910N	156-14.3069W	1:12	1:24	245	219	144	1232	505
189	2015/09/24	72-10.4048N	156-14.4414W	1:25	1:31	245	207	144	1232	505
190	2015/09/24	72-10.2746N	155-51.9208W	3:20	3:28	273	230	144	1232	505
191	2015/09/24	72-10.3237N	155-51.6392W	3:32	3:39	273	217	144	1232	505
192	2015/09/24	-	-	-	-	-	-	144	1232	505
193	2015/09/24	72-09.8910N	156-40.4147W	6:44	6:49	186	163	144	1232	505
194	2015/09/24	72-09.9104N	156-40.3253W	6:57	6:51	186	156	144	1232	505
195	2015/09/24	72-10.1091N	157-10.8884W	8:54	8:58	113	78	144	1232	505
196	2015/09/24	72-10.1283N	157-10.7626W	9:00	9:03	113	78	144	1232	505
197	2015/09/25	73-18.1218N	160-47.4546W	15:34	15:42	430	280	144	1232	505
198	2015/09/25	73-18.3428N	160-47.1470W	15:51	16:00	430	281	144	1232	505
199	2015/09/25	73-12.8636N	161-15.8414W	18:24	18:34	372	295	144	1232	505
200	2015/09/25	73-12.9412N	161-15.6286W	18:41	18:50	372	305	144	1232	505
201	2015/09/25	73-07.8139N	162-17.9991W	22:19	22:26	198	170	144	1232	505
202	2015/09/25	73-07.7317N	162-18.0763W	22:30	22:35	196	165	144	1232	505
203	2015/09/26	73-03.6051N	163-38.9301W	2:01	2:07	104	80	144	1232	505
204	2015/09/26	73-03.6028N	163-39.1599W	2:09	2:11	104	86	144	1232	505
205	2015/09/26	73-03.5831N	163-39.4079W	2:14	2:17	104	76	144	1232	505
206	2015/09/26	73-03.4983N	164-37.1991W	4:55	5:00	74	46	144	1232	505
207	2015/09/26	73-03.5126N	164-37.3160W	5:04	5:06	74	26	144	1232	505
208	2015/09/26	73-03.4499N	164-37.5318W	5:08	5:10	74	53	144	1232	505
209	2015/09/26	73-18.2477N	160-45.9918W	18:03	18:12	437	268	144	1232	505
210	2015/09/26	73-18.3038N	160-45.8473W	18:19	18:27	437	286	144	1232	505
211	2015/09/27	72-58.8058N	161-11.7941W	5:14	5:18	91	79	144	1232	505
212	2015/09/27	72-58.8113N	161-11.7285W	5:19	5:22	91	85	144	1232	505

213	2015/09/27	72-58.8116N	161-11.6406W	5:24	5:27	91	83	144	1232	505
214	2015/09/27	73-06.6599N	161-35.2337W	6:59	-	200	154	144	1232	505
215	2015/09/27	72-06.5999N	161-35.2735W	7:09	7:15	200	180	144	1232	505
216	2015/09/27	73-14.6354N	161-58.6258W	8:48	8:54	174	153	144	1232	505
217	2015/09/27	73-14.6289N	161-58.4312W	8:57	9:03	174	152	144	1232	505
218	2015/09/27	73-14.6245N	161-58.2253W	9:06	9:11	174	156	144	1232	505
219	2015/09/27	73-22.4698N	162-21.7213W	10:55	11:01	138	118	144	1232	505
220	2015/09/27	73-22.4093N	162-21.5006W	11:03	11:07	138	113	144	1232	505
221	2015/09/27	73-22.3479N	162-21.3381W	11:10	11:14	138	113	144	1232	505
222	2015/09/27	73-30.3784N	162-45.9392W	12:53	12:59	244	138	144	1232	505
223	2015/09/27	73-30.3295N	162-45.8725W	13:02	13:06	244	137	144	1232	505
224	2015/09/27	73-30.2952N	162-45.8029W	13:09	13:14	244	138	144	1232	505
225	2015/09/27	73-28.3724N	160-07.8098W	23:23	23:37	1630	442	144	1232	505
226	2015/09/27	73-28.4064N	160-07.3415W	23:45	23:58	1630	448	144	1232	505
227	2015/09/28	74-30.1298N	168-45.0797W	0:56	1:02	191	148	144	1232	505
228	2015/09/28	74-30.1344N	168-45.0638W	1:05	1:12	191	183	144	1232	505
229	2015/09/28	74-30.1569N	168-45.0120W	1:15	1:20	191	163	144	1232	505
230	2015/09/28	74-00.1046N	168-45.2895W	5:14	5:21	181	170	144	1232	505
231	2015/09/28	74-00.0555N	168-45.3246W	5:24	5:30	181	159	144	1232	505
232	2015/09/28	74-00.0223N	168-45.2092W	5:34	5:40	181	163	144	1232	505
233	2015/09/28	73-29.8017N	168-45.8849W	9:52	19:57	117	97	144	1232	505
234	2015/09/28	73-29.7668N	168-45.9879W	10:00	10:03	117	83	144	1232	505
235	2015/09/28	73-29.7253N	168-45.9962W	10:05	10:08	117	91	144	1232	505
236	2015/09/29	71-59.8950N	168-44.4913W	23:04	23:07	58	36	144	1232	505
237	2015/09/29	71-59.8795N	168-44.5007W	23:07	23:09	58	34	144	1232	505
238	2015/09/29	71-59.8737N	168-44.5259W	23:09	23:11	58	37	144	1232	505
239	2015/09/30	71-29.9414N	168-44.9091W	2:57	3:00	-	31	144	1232	505
240	2015/09/30	71-29.9281N	168-44.9158W	3:00	3:03	-	36	144	1232	505
241	2015/09/30	71-29.9091N	168-44.9318W	3:03	3:05	-	42	144	1232	505
242	2015/09/30	70-59.7673N	168-44.8552W	6:45	6:49	45	34	144	1232	505
243	2015/09/30	70-59.7494N	168-44.8489W	6:49	6:51	-	38	144	1232	505
244	2015/09/30	70-59.7303N	168-44.8627W	6:53	6:53	-	38	144	1232	505
245	2015/09/30	70-29.7527N	168-45.2148W	10:08	10:11	38	26	144	1232	505
246	2015/09/30	70-29.7354N	168-45.2516W	10:11	10:13	-	32	144	1232	505
247	2015/09/30	70-29.7248N	168-45.2706W	10:13	10:15	-	32	144	1232	505
248	2015/10/01	67-59.7967N	168-44.9358W	0:32	0:36	58	46	144	1232	505

249	2015/10/01	67-59.7742N	168-44.9692W	0:38	0:40	58	37	144	1232	505
250	2015/10/01	67-59.7242N	168-44.9892W	0:41	0:43	58	35	144	1232	505
251	2015/10/01	68-29.7347N	168-45.1212W	4:26	4:29	-	29	144	1232	505
252	2015/10/01	68-29.7076N	168-45.1352W	4:29	4:31	-	39	144	1232	505
253	2015/10/01	68-29.6803N	168-45.1469W	4:32	4:34	-	36	144	1232	505
254	2015/10/01	69-00.0699N	168-44.9781W	7:46	7:48	52	30	144	1232	505
255	2015/10/01	69-00.0470N	168-44.9520W	7:49	7:51	52	41	144	1232	505
256	2015/10/01	69-00.0249N	168-44.9240W	7:52	7:54	52	46	144	1232	505
257	2015/10/03	67-00.1430N	168-44.6879W	9:50	9:52	45	30	144	1232	505
258	2015/10/03	67-00.1905N	168-44.6110W	9:55	9:56	45	35	144	1232	505
259	2015/10/03	67-00.2279N	168-44.5444W	9:57	9:59	45	34	144	1232	505
260	2015/10/03	67-00.2607N	168-44.4906W	9:59	10:01	45	37	144	1232	505
261	2015/10/03	67-00.2936N	168-44.4302W	10:02	10:04	45	37	144	1232	505
262	2015/10/03	66-00.2802N	168-44.7285W	16:28	16:31	50	41	144	1232	505
263	2015/10/03	66-00.3382N	168-44.6596W	16:35	16:37	50	41	144	1232	505
264	2015/10/03	66-00.3897N	168-44.6473W	16:37	16:39	50	44	144	1232	505
265	2015/10/03	66-00.4313N	168-44.6254W	16:41	16:42	50	43	144	1232	505
266	2015/10/03	66-00.4682N	168-44.5944W	16:43	16:45	50	45	144	1232	505

3.6. Drifting buoys

(1) Personnel

Yusuke Kawaguchi (JAMSTEC): Principal investigator

Hiroki Takeda (JAMSTEC / Tokyo Gakugei University)

Shigeto Nishino (JAMSTEC)

Kazuhiro Oshima (JAMSTEC)

Keisuke Matsumoto (MWJ)

(2) Objectives

To examine subsurface ocean current and mesoscale structures, e.g. frontal jet and eddies, in the Western Arctic Ocean.

(3) Parameters

Geographical position (longitude, latitude) from drifting buoys

(4) Instruments and methodology

We utilized Surface Velocity Profiler (SVP) (manufactured by Zeni Lite Buoy Co., Ltd.), which comprises a surface-floating unit (a geographical-positioning-system (GPS) sensor and Iridium communication system) and a holey-sock drogue at mid-depth; they are connected with a fabric nylon rope with each other. The rope length is adjusted on the deck so that it could capture the accurate current velocity at a water depth of scientific interest. Once buoys are successfully deployed, a SVP sends hourly GPS information to the email addresses registered, with nearly 15 m horizontal accuracy. The holey-sock drogue is considered to catch current velocity with an accuracy of within 10% of absolute current magnitude at the drogued depth.

One of objectives for this cruise is to explore and identify natures of mesoscale eddies in the Arctic Ocean. In practice, we could encounter a strong cyclonic eddy in the middle of the cruise, and then tracked it for weeks using those SVPs. We have made in total five of SVP deployments in the area off the Barrow Canyon. First, two of SVP units (SVP4000 and SVP2010) have been deployed on a date of respectively 13th and 16th September in 2015, that was just prior to the fixed-point-observation part 1 (FPO-1) inside the eddy started. Then, SVP2370 and SVP4370 were subsequently deployed on 18th and 20th September, respectively. Lastly, the deployment of SVP3390 has been made on 22nd September, when we left the FPO-2 station at (72.23°N, 156.16°W). A rope length (consequently, the drogued depth) was uniform to be 50 m for the overall SVPs (Figure 3.6-1).

(5) Observation logs

Deployment information such as identification number, deployment time and GPS information for each buoy is summarized in Table 3.6-1.

(6) Data archives

These data obtained in this cruise will be submitted to the Data Management Group of JAMSTEC, and will be opened to the public via “Data Research System for Whole Cruise Information in JAMSTEC (DARWIN)” in JAMSTEC web site.

Table 3.6-1: SVP deployment information

Unit NO.	Deployment information			Drogue depth [m]
	Date [YYYY/MM/DD]	Longitude [deg. N]	Latitude [deg. E]	
SVP4000	2015/09/08	72.31	-155.42	50
SVP2010	2015/09/09	72.30	-155.19	50
SVP2370	2015/09/12	72.36	-155.42	50
SVP4370	2015/09/20	72.28	-155.99	50
SVP3390	2015/09/22	72.23	-156.16	50

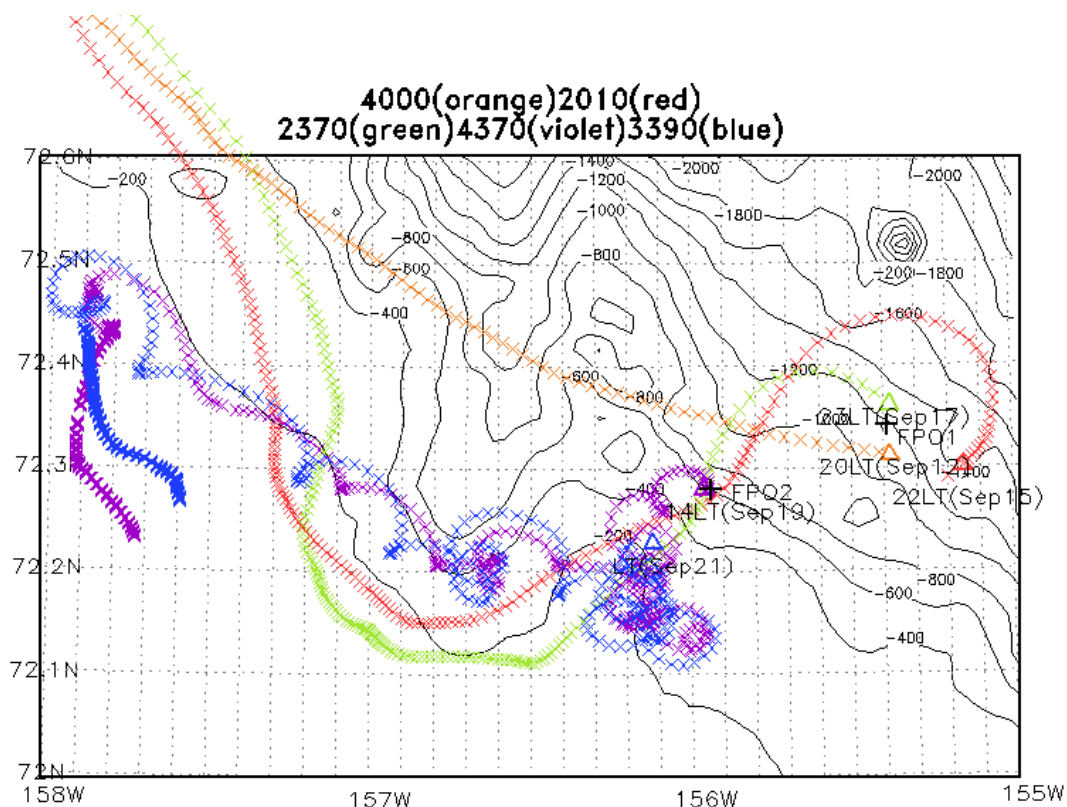

Figure 3.6-1: Trajectories of drifting buoys: SVP4000 (orange), SVP2010 (red), SVP2370 (green), SVP4370 (violet) and SVP3390 (blue) during dates between 13–30 September,

2015. The GPS information is taken at a constant rate of every an hour. A mark + in solid black shows geographical positions of each FPO program: FPO-1 and FPO-2. Solid contours indicate a bottom relief retrieved from ETOPO-2. (Figure courtesy: H. Takeda)

3.7. Salinity measurements

(1) Personnel

Shigeto Nishino (JAMSTEC): Principal investigator

Sonoka Wakatsuki(MWJ)

(2) Objectives

To understand the spatial and temporal variation of salinity and to provide calibrations for the measurements of salinity collected from CTD and TSG (Underway surface water monitoring).

(3) Parameters

The specifications of the AUTOSAL salinometer are shown as follows ;

Salinometer (Model 8400B “AUTOSAL” ; Guildline Instruments Ltd.)

Measurement Range : 0.005 to 42 (PSU)

Accuracy : Better than ± 0.002 (PSU) over 24 hours
without re-standardization

Maximum Resolution : Better than ± 0.0002 (PSU) at 35 (PSU)

(4) Instruments and methods

a. Salinity Sample Collection

Seawater samples were collected with 12 liter Niskin-X bottles, bucket, and TSG. The salinity sample bottle of 250ml brown glass with screw cap was used for collecting the sample water. Each bottle was rinsed 3 times with the sample water, and was filled with sample water to the bottle shoulder. All of sample bottles for TSG were sealed with a plastic insert thimble and a screw cap because we took into consideration the possibility of storage for about a month. The thimble was rinsed 3 times with the sample water before use. The bottle was stored for more than 24 hours in the laboratory before the salinity measurement.

Types and numbers (n) of the samples are shown in Table 3.7-1.

Table 3.7-1 Types and numbers (n) of samples

Types	N
Samples for CTD and bucket	1322
Samples for TSG	47
Total	1369

b. Instruments and method

The salinity analysis was carried out on R/V MIRAI during the cruise of MR15-03 using the salinometer (Model 8400B “AUTOSAL” ; Guildline Instruments Ltd.: S/N 62556 and S/N 62827) with an additional peristaltic-type intake pump (Ocean Scientific International, Ltd.).

One pair of precision digital thermometers (Model 9540 ; Guildline Instruments

Ltd.) were used. The thermometer monitored the ambient temperature and the other monitored the bath temperature.

The specifications of the thermometer are shown as follows ;

Thermometer (Model 9540 ; Guildline Instruments Ltd.)

Measurement Range	: -40 to +180 deg C
Resolution	: 0.001
Limits of error \pm deg C	: 0.01 (24 hours @ 23 deg C \pm 1 deg C)
Repeatability	: \pm 2 least significant digits

The measurement system was almost the same as Aoyama *et al.* (2002). The salinometer was operated in the air-conditioned ship's laboratory at a bath temperature of 21 deg C. The ambient temperature varied from approximately 17.0 deg C to 22.2 deg C, while the bath temperature was very stable and varied within \pm 0.004 deg C (S/N 62556) and \pm 0.008 deg C (S/N 62827) on rare occasion.

The measurement for each sample was done with a double conductivity ratio and defined as the median of 31 readings of the salinometer. Data collection was started 10 seconds after filling the cell with the sample and it took about 15 seconds to collect 31 readings by the personal computer. Data were taken for the sixth and seventh filling of the cell after rinsing 5 times. In the case of the difference between the double conductivity ratio of these two fillings being smaller than 0.00002, the average value of the double conductivity ratio was used to calculate the bottle salinity with the algorithm for the practical salinity scale, 1978 (UNESCO, 1981). If the difference was greater than or equal to 0.00003, an eighth filling of the cell was done. In the case of the difference between the double conductivity ratio of these two fillings being smaller than 0.00002, the average value of the double conductivity ratio was used to calculate the bottle salinity. In the case of the double conductivity ratio of eighth filling did not satisfy the criteria above, the operator measured a ninth or tenth filling of the cell and calculated the bottle salinity above. The cell was cleaned with detergent after the measurement of the day.

(5) Station list

Table.3.7-1 shows the sampling locations for the salinity analysis in this cruise.

Table. 3.7-1 The sampling locations of the salinity samples collected from CTD

Stnnbr	Castno	Date(UTC)	BottomPosition		Depth
		(mmddy)	Latitude	Longitude	
001	1	090615	65-45.69N	168-45.19W	51.8
002	1	090615	66-00.02N	168-45.26W	52.8
003	1	090615	66-30.09N	168-45.58W	51.9
004	1	090615	67-00.08N	168-44.99W	44.9
005	1	090615	67-30.02N	168-45.12W	49.5
006	2	090715	67-59.90N	168-46.64W	58.1
007	1	090715	68-30.00N	168-45.10W	53.1
008	1	090715	69-00.04N	168-44.86W	52.5
009	1	090715	69-30.04N	168-44.91W	51.3
010	1	090715	69-59.97N	168-44.98W	40.8
011	1	090715	70-30.09N	168-45.13W	38.6
012	1	090815	70-59.95N	168-45.12W	44.4
013	1	090815	71-20.10N	157-39.87W	98.6
014	1	090915	71-34.73N	157-50.25W	64.6
015	1	090915	71-24.81N	157-30.04W	122.7
016	1	090915	71-14.89N	157-09.66W	46.5
022	1	091115	71-35.99N	154-50.22W	42.0
023	1	091115	71-44.44N	155-12.65W	307.0
024	1	091115	71-52.67N	156-01.78W	81.1
025	1	091215	71-49.50N	155-50.76W	88.5
026	1	091215	71-48.26N	155-22.71W	149.3
027	1	091215	71-39.95N	155-01.41W	104.0
028	1	091215	72-00.06N	157-28.04W	78.6
029	1	091215	72-07.94N	156-58.04W	131.0
030	1	091215	72-17.37N	156-42.13W	272.0
031	1	091315	72-06.21N	154-40.63W	1096.0
032	1	091315	71-59.99N	154-42.40W	1008.0
033	1	091415	71-55.03N	154-58.30W	334.0
035	1	091415	72-01.31N	155-53.57W	148.3
037	1	091415	72-11.04N	155-39.07W	367.0
039	2	091415	72-23.54N	155-28.00W	1350.0
040	1	091515	72-26.18N	156-35.45W	870.0
045	1	091515	72-12.49N	156-50.64W	188.0
046	1	091515	72-03.91N	157-13.19W	88.0
047	1	091515	71-57.09N	158-00.06W	65.8
048	1	091515	72-08.32N	157-23.33W	76.2
049	1	091515	72-00.06N	156-53.65W	95.2
050	1	091615	72-05.08N	156-25.93W	149.0
051	1	091615	72-11.44N	156-12.79W	253.9
052	1	091615	72-20.20N	156-10.51W	1076.0
053	4	091615	72-20.42N	155-23.49W	1619.0

053	8	091715	72-20.37N	155-23.10W	1617.0
053	12	091715	72-21.32N	155-23.56W	1682.0
053	16	091815	72-20.50N	155-23.50W	1626.0
054	2	091815	72-28.25N	155-23.47W	1998.0
055	1	091915	72-22.93N	155-59.76W	1375.0
056	4	092015	72-16.29N	155-57.29W	444.0
056	8	092015	72-17.55N	156-01.64W	917.0
056	10	092115	72-16.94N	155-59.36W	789.0
056	12	092115	72-16.77N	155-58.53W	679.0
056	16	092115	72-16.90N	155-59.09W	761.0
060	1	092215	72-11.15N	153-33.50W	2110.0
061	1	092215	72-01.29N	153-50.65W	1537.0
062	1	092215	71-49.93N	153-49.47W	176.0
063	1	092315	72-22.25N	155-31.12W	1302.0
064	1	092315	72-15.87N	155-57.94W	424.0
065	1	092315	72-11.67N	156-15.49W	258.0
066	1	092315	72-15.98N	156-24.88W	398.0
067	1	092315	72-10.05N	155-30.91W	380.0
068	1	092415	72-10.47N	156-13.45W	242.0
069	1	092415	72-10.07N	155-52.48W	274.0
070	1	092415	72-10.05N	156-40.72W	188.0
071	1	092415	72-10.07N	157-11.24W	113.0
072	1	092415	72-34.87N	159-41.40W	54.9
074	1	092415	72-46.81N	159-06.01W	183.0
075	1	092415	73-12.53N	157-48.22W	2595.0
077	1	092515	72-53.23N	158-48.04W	362.0
081	1	092515	73-12.82N	161-15.81W	371.0
082	1	092515	73-08.15N	162-17.91W	201.0
083	1	092615	73-03.57N	163-38.23W	106.0
084	1	092615	73-03.47N	164-36.11W	75.0
085	2	092615	73-18.61N	160-45.60W	437.0
094	1	092715	73-28.52N	160-08.16W	1615.0
095	1	092815	73-34.07N	165-56.20W	103.0
096	1	092815	73-53.19N	166-09.95W	153.0
098	2	092815	74-27.76N	166-37.02W	316.0
099	1	092915	74-30.02N	168-45.11W	194.0
100	1	092915	74-00.00N	168-45.29W	181.0
101	1	092915	73-29.92N	168-45.37W	120.0
102	1	092915	72-00.10N	168-44.74W	51.0
103	1	093015	71-30.00N	168-44.98W	48.7
104	1	093015	70-59.92N	168-44.80W	45.0
105	1	093015	70-29.96N	168-45.13W	38.0
106	1	100115	67-59.90N	168-44.82W	58.0
107	1	100115	68-29.93N	168-45.01W	54.0
108	1	100315	67-00.02N	168-44.89W	45.0
109	1	100315	66-00.12N	168-45.04W	52.5

(6) Preliminary results

a. Standard Seawater (SSW)

The specifications of SSW used in this cruise are shown as follows ;

Batch	: P157
conductivity ratio	: 0.99985
double conductivity ratio	: 1.99970
salinity	: 34.994
expiration date	: 15 th May 2017

Standardization control of the salinometer S/N 62556 was set to 577 (3rd Sep.) and 10 measurements were carried out at this setting. The value of STANDBY was 5115 +/- 0001 and that of ZERO was 0.0-0000 +/- 0001. 34 bottles of SSW were measured in this period. Because measurement values of the salinometer S/N 62556 was shifted, re-standardization control of this salinometer was set to 586 (22nd Sep.) and 1 measurement were carried out at this setting. The value of STANDBY was 5122 +/- 0001 and that of ZERO was 0.0-0000 +/- 0001. 4 bottles of SSW were measured in this period. Because the salinometer S/N 62556 was shifted again, the salinometer was changed from S/N 62556 to S/N 62827. Standardization control of the salinometer S/N 62827 was set to 402 (23rd Sep.) and 14 measurements were carried out at this setting. The value of STANDBY was 5290 +/- 0002 and that of ZERO was 0.0+0000 +/- 0001. 35 bottles of SSW were measured in this period.

Fig.3.7-1 shows the history of the double conductivity ratio of the Standard Seawater batch P157 before correction in the salinometer S/N 62556. The average of the double conductivity ratio in 34 bottles of SSW was 1.99963 and the standard deviation was 0.00005, which is equivalent to 0.0010 in salinity. In addition, average of the double conductivity ratio in 4 bottles of SSW after re-standardization control of this salinometer was 1.99965 and the standard deviation was 0.00005, which is equivalent to 0.0010 in salinity.

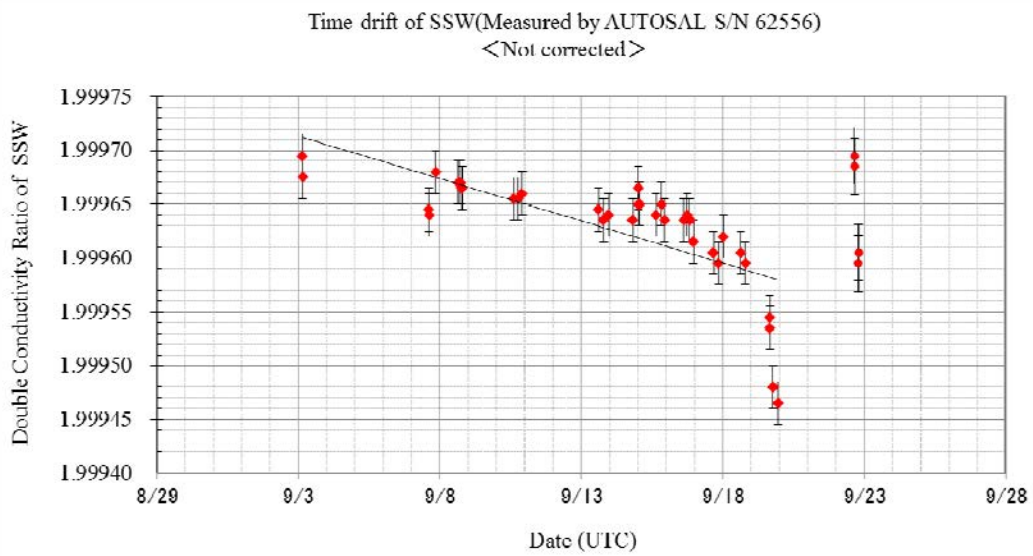

Fig. 3.7-1 History of double conductivity ratio for the Standard Seawater batch P157 in the salinometer S/N 62556 (before correction)

Fig.3.7-2 shows the history of the double conductivity ratio of the Standard Seawater batch P157 after correction in the salinometer S/N 62556. The average of the double conductivity ratio in 34 bottles of SSW after correction was 1.99970 and the standard deviation was 0.00001, which is equivalent to 0.0002 in salinity. In addition, the average of the double conductivity ratio in 4 bottles of SSW after re-standardization control of the salinometer was 1.99966 and the standard deviation was 0.00005, which is equivalent to 0.0010 in salinity.

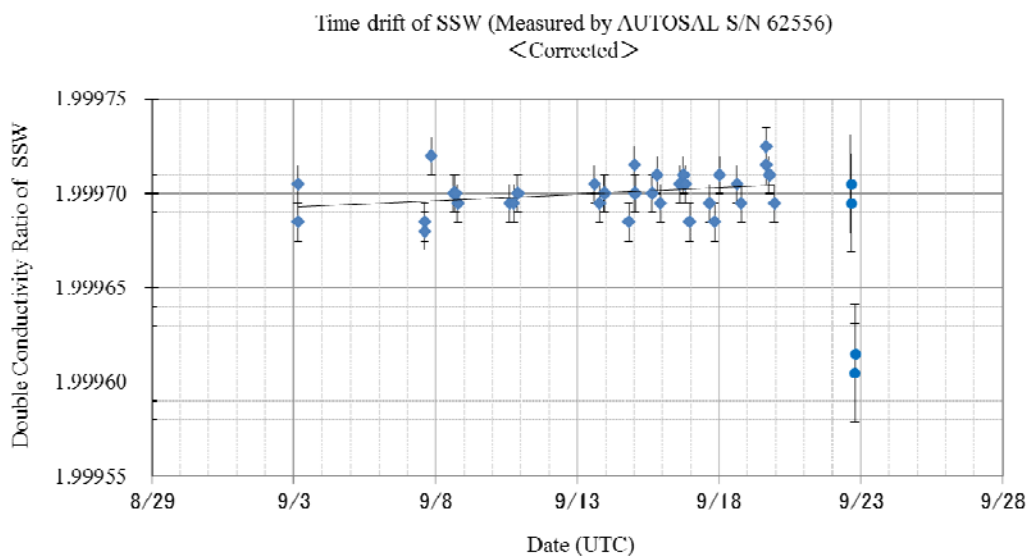

Fig. 3.7-2 History of double conductivity ratio for the Standard Seawater batch P157

in the salinometer S/N 62556 (after correction)

Fig.3.7-3 shows the history of the double conductivity ratio of the Standard Seawater batch P157 before correction in the salinometer S/N 62827. The average of the double conductivity ratio in 35 bottles of SSW was 1.99969 and the standard deviation was 0.00001, which is equivalent to 0.0002 in salinity.

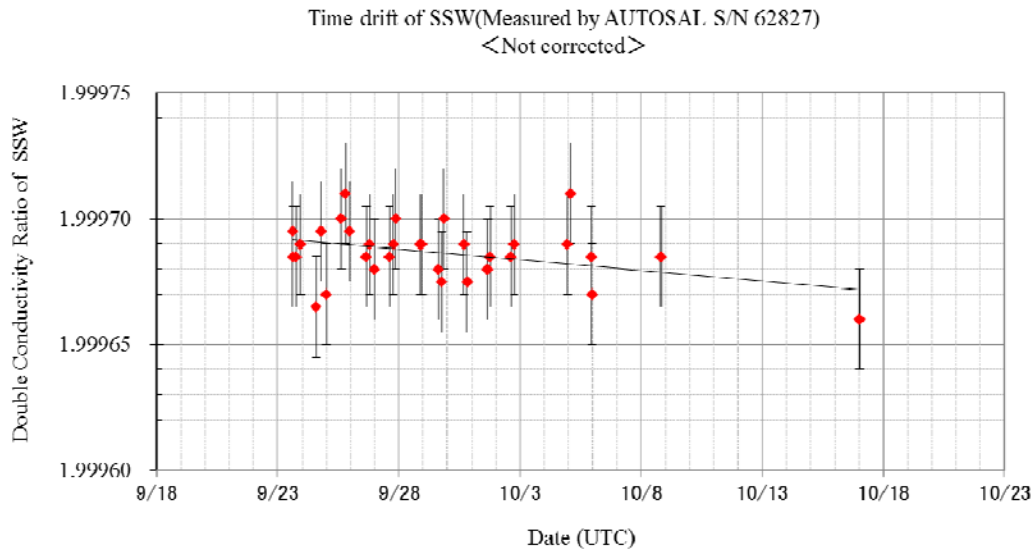

Fig. 3.7-3 History of double conductivity ratio for the Standard Seawater batch P157 in the salinometer S/N 62827 (before correction)

Fig.3.7-4 shows the history of the double conductivity ratio of the Standard Seawater batch P157 after correction in the salinometer S/N 62827. The average of the double conductivity ratio in 35 bottles of SSW after correction was 1.99970 and the standard deviation was 0.00001, which is equivalent to 0.0002 in salinity.

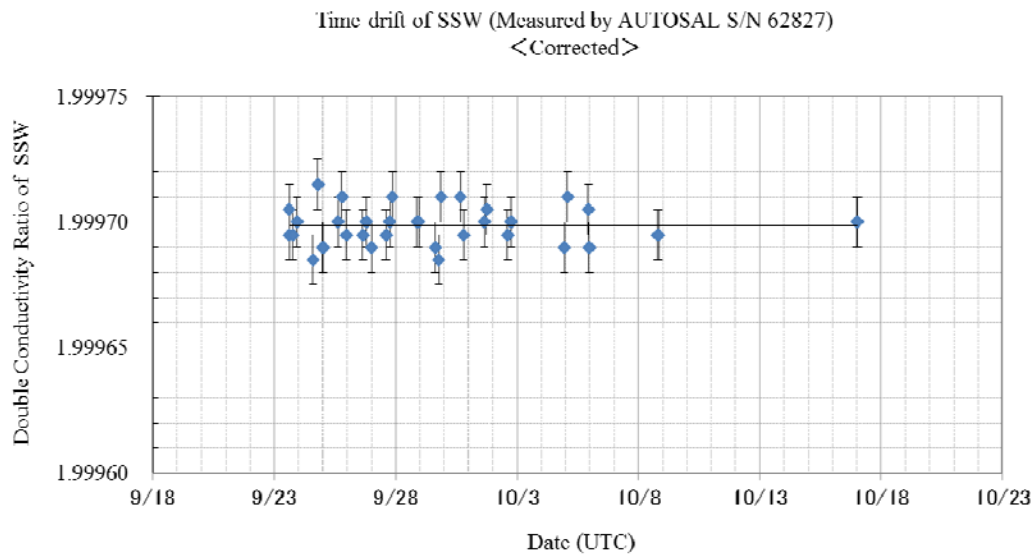

Fig. 3.7-4 History of double conductivity ratio for the Standard Seawater batch P157 in the salinometer S/N 62827 (after correction)

b. Sub-Standard Seawater

Sub-standard seawater was made from surface-sea water (poor in nutrient) filtered by a pore size of 0.45 micrometer and stored in a 20 liter container made of polyethylene and stirred for at least 24 hours before measuring. It was measured between every station in order to check for the possible sudden drifts of the salinometer.

c. Replicate Samples

We estimated the precision of this method using 190 pairs of replicate samples taken from the same Niskin bottle.

Fig.3.7-5 shows the histogram of the absolute difference between each pair of all replicate samples. The average and the standard deviation of absolute difference among 190 pairs were 0.0007 and 0.0018 in salinity, respectively.

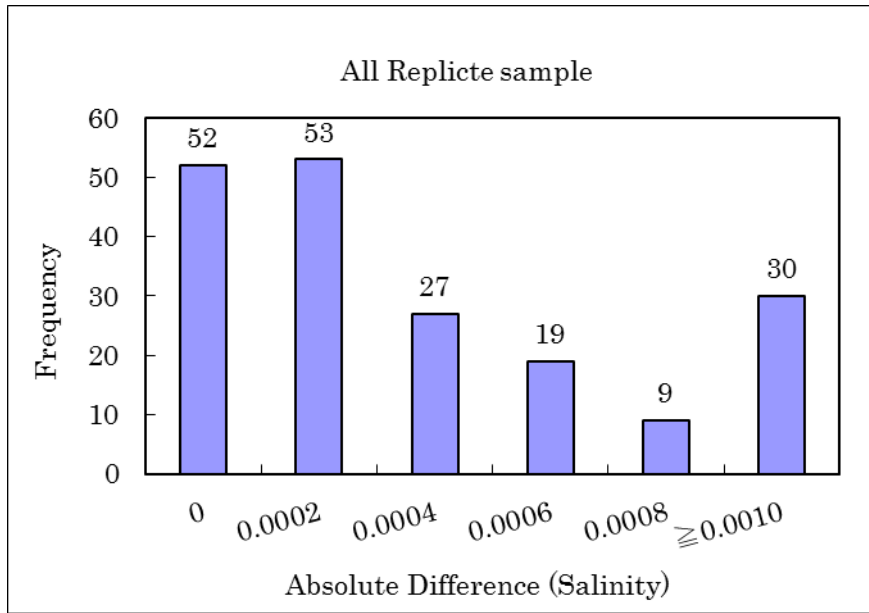

Fig. 3.7-5 Histogram of the Absolute Difference of all Replicate Samples

136 pairs of replicate samples were to estimate the precision of shallow (<200dbar) samples. Fig.3.7-6 shows the histogram of the absolute difference between each pair of shallow (<200dbar) replicate samples. The average and the standard deviation of absolute difference among 136 pairs were 0.0009 and 0.0021 in salinity, respectively.

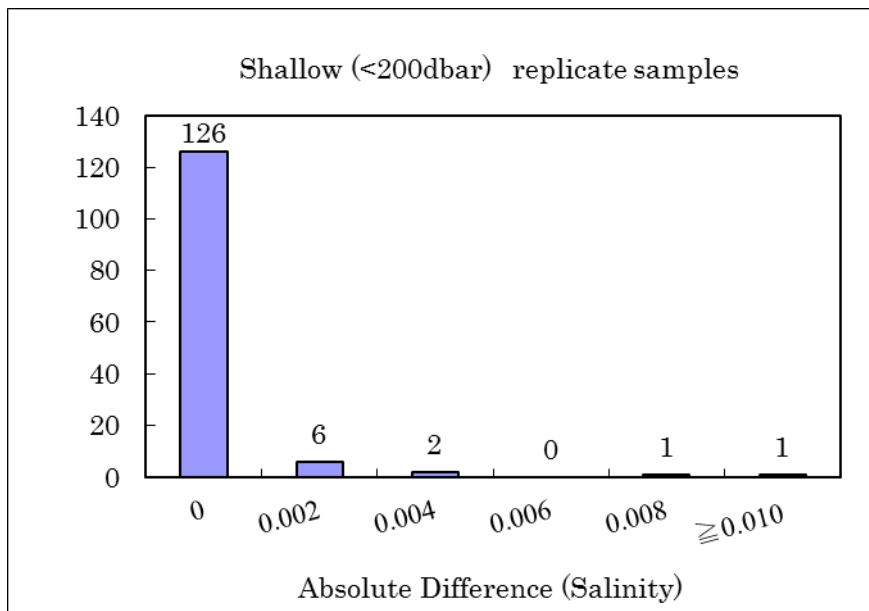

Fig. 3.7-6 Histogram of the Absolute Difference between Shallow (<200dbar) Replicate Samples

54 pairs of replicate samples were to estimate the precision of deep (≥ 200 dbar) samples. Fig.3.7-7 shows the histogram of the absolute difference between each pair of deep (≥ 200 dbar) replicate samples. The average and the standard deviation of absolute difference among 54 pairs were 0.0003 and 0.0002 in salinity, respectively.

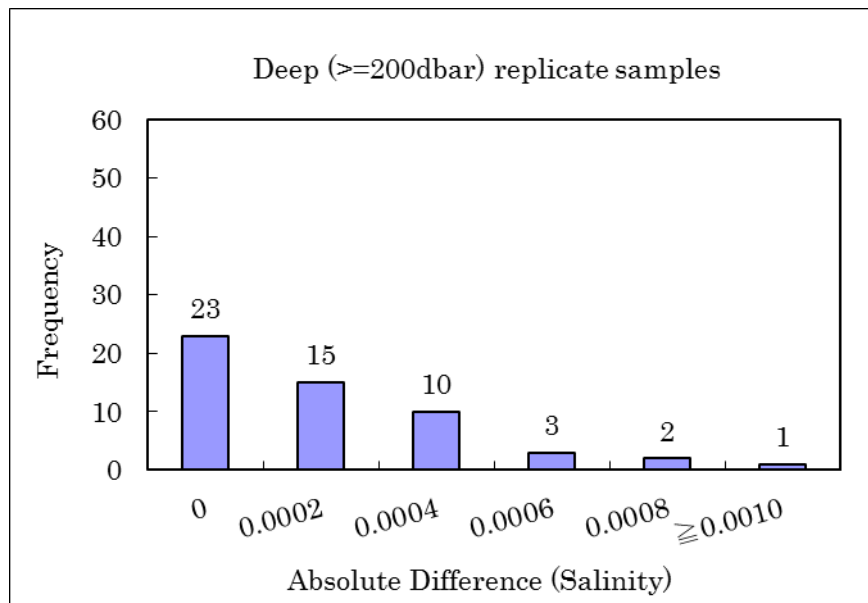

Fig. 3.7-7 Histogram of the Absolute Difference between Deep (≥ 200 dbar) Replicate Samples

d. Data Correction for Samples

All data were corrected according to the result of the offset correction for SSW.

(7) Data archives

a. Data Policy

These data obtained in this cruise will be submitted to the Data Management Group of JAMSTEC, and will be opened to the public via “Data Research System for Whole Cruise Information in JAMSTEC (DARWIN)” in JAMSTEC web site.

<<http://www.godac.jamstec.go.jp/darwin/e>>

b. Citation

- Aoyama, M., T. Joyce, T. Kawano and Y. Takatsuki : Standard seawater comparison up to P129. Deep-Sea Research, I, Vol. 49, 1103~1114, 2002
- UNESCO : Tenth report of the Joint Panel on Oceanographic Tables and Standards. UNESCO Tech. Papers in Mar. Sci., 36, 25 pp., 1981

3.8. Density

(1) Personnel

Hiroshi Uchida (JAMSTEC): Principal investigator
Shigeto Nishino (JAMSTEC)

(2) Objective

The objective of this study is to collect absolute salinity (also called “density salinity”) data, and to evaluate an algorithm to estimate absolute salinity provided along with TEOS-10 (the International Thermodynamic Equation of Seawater 2010) (IOC et al., 2010).

(3) Parameter

Density (density salinity)

(4) Instruments and methods

Seawater densities were measured after the cruise with an oscillation-type density meter (DMA 5000M, serial no. 80570578, Anton-Paar GmbH, Graz, Austria) with a sample changer (Xsample 122, serial no. 80548492, Anton-Paar GmbH) in a laboratory of JAMSTEC, Yokosuka. The sample changer was used to load samples automatically from up to ninety-six 12-mL glass vials.

The water samples were collected in 100-mL aluminum bottles (Mini Bottle Can, Daiwa Can Company, Japan). The bottles were stored at room temperature (~23 °C) upside down. Densities of the samples were measured at 20 °C by the density meter two times for each bottle and averaged to estimate the density. When the difference between the two measurements was greater than 0.002 kg m⁻³, additional measurements were conducted until two samples satisfying the above criteria were obtained.

Time drift of the density meter was monitored by periodically measuring the density of ultra-pure water (Milli-Q water, Millipore, Billerica, Massachusetts, USA) prepared from Yokosuka (Japan) tap water in October 2012. The true density at 20 °C of the Milli-Q water was estimated to be 998.2042 kg m⁻³ from the isotopic composition ($\delta D = -8.76$ ‰, $\delta^{18}O = -56.86$ ‰) and International Association for the Properties of Water and Steam (IAPWS)-95 standard. An offset correction was applied to the measured density by using the Milli-Q water measurements ($\rho_{\text{Milli-Q}}$) with a slight modification of the density dependency (Uchida et al., 2011). The offset (ρ_{offset}) of the measured density (ρ) was estimated from the following equation:

$$\rho_{\text{offset}} = (\rho_{\text{Milli-Q}} - 998.2042) - (\rho - 998.2042) \times 0.000241 \text{ [kg m}^{-3}\text{]}.$$

The offset correction was verified by measuring Reference Material for Density of Seawater (prototype Dn-RM1) developing with Marine Works Japan, Ltd., Kanagawa, Japan, and produced by Kanso Technos Co., Ltd., Osaka, Japan, along with the Milli-Q water.

Density salinity can be back calculated from measured density and temperature (20 °C) with TEOS-10.

(5) Results

Results of density measurements of Dn-RM1 are shown in Table 3.8-1.

A total of 28 pairs of replicate samples were measured. The root-mean square of the absolute difference of replicate samples was 0.0013 g/kg.

The measured density salinity anomalies (δS_A) are shown in Fig. 3.8-1. The measured δS_A well agree with calculated δS_A from Pawlowicz et al. (2011) which exploits the correlation between δS_A and nutrient concentrations and carbonate system parameters based on mathematical investigation using a model relating composition, conductivity and density of arbitrary seawaters.

(6) Observation log

The sampling list is summarized in Table 3.8-2.

(7) References

IOC, SCOR and IAPSO (2010): The international thermodynamic equation of seawater – 2010: Calculation and use of thermodynamic properties. Intergovernmental Oceanographic Commission, Manuals and Guides No. 56, United Nations Educational, Scientific and Cultural Organization (English), 196 pp.

Pawlowicz, R., D. G. Wright and F. J. Millero (2011): The effects of biogeochemical processes on ocean conductivity/salinity/density relationships and the characterization of real seawater. *Ocean Science*, 7, 363–387.

Uchida, H., T. Kawano, M. Aoyama and A. Murata (2011): Absolute salinity measurements of standard seawaters for conductivity and nutrients. *La mer*, 49, 237–244.

(8) Data archives

These data obtained in this cruise will be submitted to the Data Management Group of JAMSTEC, and will be opened to the public via “Data Research System for Whole Cruise Information in JAMSTEC (DARWIN)” in JAMSTEC web site.

Table 3.8-1: Result of density measurements of the Reference Material for Density in Seawater (prototype Dn-RM1).

Date	Sample bottle no.	Mean density of Dn-RM1 (kg/m ³)	Note
2015/12/22	001-005	1024.2651	
	006-009	1024.2640	
2015/12/23	010-022	1024.2632	
	none	1024.2625	
2015/12/24	023-026	1024.2620	
	026-029	1024.2617	
2015/12/25	029-031	1024.2639	
	031-033	1024.2614	
2015/12/26	033-039	1024.2629	
	039-040	1024.2615	
2015/12/27	040-075	1024.2637	
	075-102	1024.2635	

Average: 1024.2630 ± 0.0012

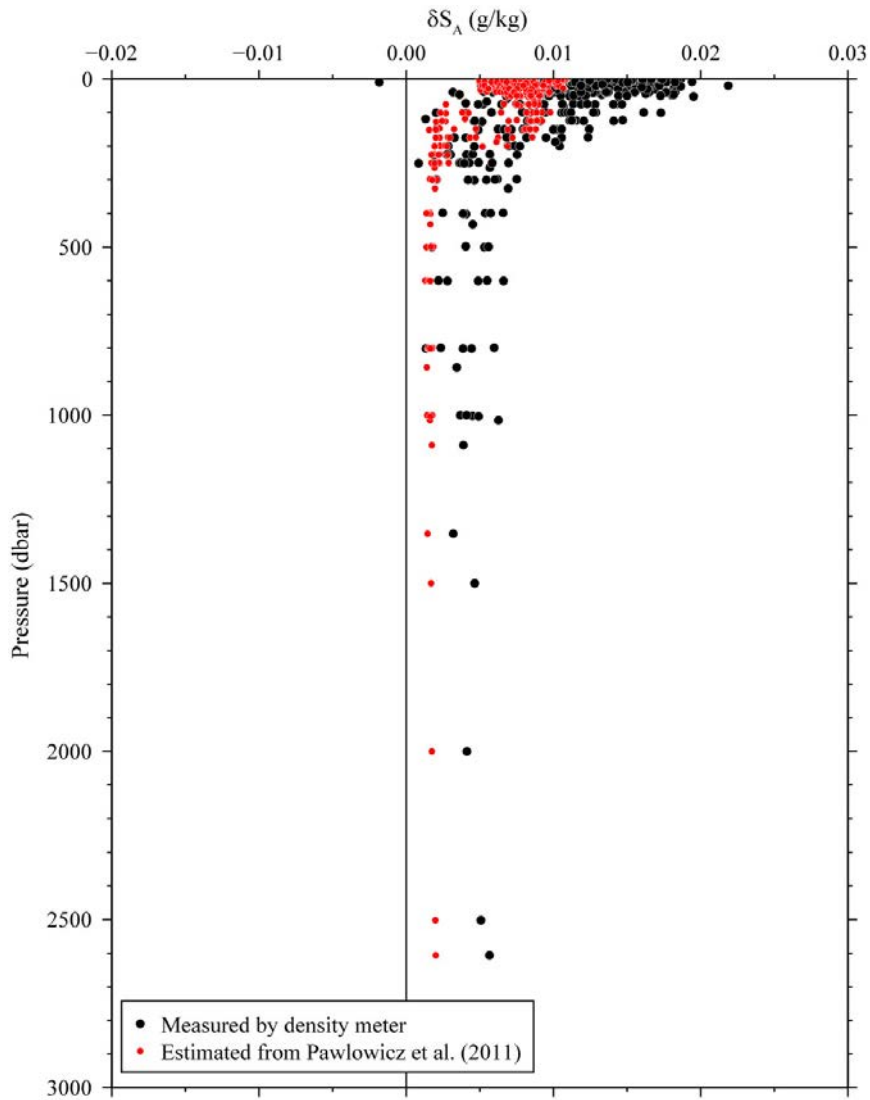

Figure 3.8-1: Vertical distribution of density salinity anomaly measured by the density meter. Absolute Salinity anomaly estimated from nutrients and carbonate parameters (Pawlowicz et al., 2011) are also shown for comparison.

Table 3.8-2: Sampling list for density (density salinity)

On board ID	Sampling Method	Date Collected				Latitude			Longitude			Depth [m]
		YYYY	MM	DD	UTC	Deg.	Min.	N/S	Deg.	Min.	E/W	
MR15-03_St001_Cast001_Den_#0181-W001	Bucket	2015	09	06	7:15	65	45.696	N	168	45.18	W	0
MR15-03_St001_Cast001_Den_#0182-W002	Niskin	2015	09	06	7:15	65	45.696	N	168	45.18	W	Chl-aMax
MR15-03_St001_Cast001_Den_#0183-W003	Niskin	2015	09	06	7:15	65	45.696	N	168	45.18	W	5
MR15-03_St001_Cast001_Den_#0184-W004	Niskin	2015	09	06	7:15	65	45.696	N	168	45.18	W	10
MR15-03_St001_Cast001_Den_#0185-W005	Niskin	2015	09	06	7:15	65	45.696	N	168	45.18	W	20
MR15-03_St001_Cast001_Den_#0186-W006	Niskin	2015	09	06	7:15	65	45.696	N	168	45.18	W	30
MR15-03_St001_Cast001_Den_#0186-W007	Niskin	2015	09	06	7:15	65	45.696	N	168	45.18	W	40
MR15-03_St001_Cast001_Den_#0187-W008	Niskin	2015	09	06	7:15	65	45.696	N	168	45.18	W	B-10
MR15-03_St001_Cast001_Den_#0189-W009	Niskin	2015	09	06	7:15	65	45.696	N	168	45.18	W	B-10
MR15-03_St002_Cast001_Den_#0190-W010	Bucket	2015	09	06	10:12	66	0.024	N	168	45.3	W	0
MR15-03_St002_Cast001_Den_#0191-W011	Niskin	2015	09	06	10:12	66	0.024	N	168	45.3	W	Chl-aMax
MR15-03_St002_Cast001_Den_#0192-W012	Niskin	2015	09	06	10:12	66	0.024	N	168	45.3	W	5
MR15-03_St002_Cast001_Den_#0193-W013	Niskin	2015	09	06	10:12	66	0.024	N	168	45.3	W	10
MR15-03_St002_Cast001_Den_#0194-W014	Niskin	2015	09	06	10:12	66	0.024	N	168	45.3	W	20
MR15-03_St002_Cast001_Den_#0195-W015	Niskin	2015	09	06	10:12	66	0.024	N	168	45.3	W	30
MR15-03_St002_Cast001_Den_#0196-W016	Niskin	2015	09	06	10:12	66	0.024	N	168	45.3	W	40
MR15-03_St002_Cast001_Den_#0197-W017	Niskin	2015	09	06	10:12	66	0.024	N	168	45.3	W	B-10
MR15-03_St002_Cast001_Den_#0198-W018	Niskin	2015	09	06	10:12	66	0.024	N	168	45.3	W	B-10
MR15-03_St003_Cast001_Den_#0199-W019	Bucket	2015	09	06	13:45	66	30.06	N	168	45.43	W	0
MR15-03_St003_Cast001_Den_#0200-W020	Niskin	2015	09	06	13:45	66	30.06	N	168	45.43	W	Chl-aMax
MR15-03_St003_Cast001_Den_#0201-W021	Niskin	2015	09	06	13:45	66	30.06	N	168	45.43	W	5
MR15-03_St003_Cast001_Den_#0202-W022	Niskin	2015	09	06	13:45	66	30.06	N	168	45.43	W	10
MR15-03_St003_Cast001_Den_#0203-W023	Niskin	2015	09	06	13:45	66	30.06	N	168	45.43	W	20
MR15-03_St003_Cast001_Den_#0204-W024	Niskin	2015	09	06	13:45	66	30.06	N	168	45.43	W	30
MR15-03_St003_Cast001_Den_#0205-W025	Niskin	2015	09	06	13:45	66	30.06	N	168	45.43	W	40
MR15-03_St003_Cast001_Den_#0206-W026	Niskin	2015	09	06	13:45	66	30.06	N	168	45.43	W	B-10
MR15-03_St003_Cast001_Den_#0207-W027	Niskin	2015	09	06	13:45	66	30.06	N	168	45.43	W	B-10
MR15-03_St004_Cast001_Den_#0208-W028	Bucket	2015	09	06	16:52	67	00.08	N	168	44.99	W	0
MR15-03_St004_Cast001_Den_#0209-W029	Niskin	2015	09	06	16:52	67	00.08	N	168	44.99	W	Chl-aMax
MR15-03_St004_Cast001_Den_#0210-W030	Niskin	2015	09	06	16:52	67	00.08	N	168	44.99	W	5
MR15-03_St004_Cast001_Den_#0211-W031	Niskin	2015	09	06	16:52	67	00.08	N	168	44.99	W	10
MR15-03_St004_Cast001_Den_#0212-W032	Niskin	2015	09	06	16:52	67	00.08	N	168	44.99	W	20
MR15-03_St004_Cast001_Den_#0213-W033	Niskin	2015	09	06	16:52	67	00.08	N	168	44.99	W	30
MR15-03_St004_Cast001_Den_#0214-W034	Niskin	2015	09	06	16:52	67	00.08	N	168	44.99	W	Not sampled

MR15-03_St004_Cast001_Den_#0215-W035	Niskin	2015	09	06	16:52	67	00.08	N	168	44.99	W	B-10
MR15-03_St004_Cast001_Den_#0216-W036	Niskin	2015	09	06	16:52	67	00.08	N	168	44.99	W	B-10
MR15-03_St005_Cast001_Den_#0217-W037	Bucket	2015	09	06	20:55	67	30.02	N	168	45.12	W	0
MR15-03_St005_Cast001_Den_#0218-W038	Niskin	2015	09	06	20:55	67	30.02	N	168	45.12	W	Chl-aMax
MR15-03_St005_Cast001_Den_#0219-W039	Niskin	2015	09	06	20:55	67	30.02	N	168	45.12	W	5
MR15-03_St005_Cast001_Den_#0220-W040	Niskin	2015	09	06	20:55	67	30.02	N	168	45.12	W	10
MR15-03_St005_Cast001_Den_#0221-W041	Niskin	2015	09	06	20:55	67	30.02	N	168	45.12	W	20
MR15-03_St005_Cast001_Den_#0222-W042	Niskin	2015	09	06	20:55	67	30.02	N	168	45.12	W	30
MR15-03_St005_Cast001_Den_#0223-W043	Niskin	2015	09	06	20:55	67	30.02	N	168	45.12	W	40
MR15-03_St005_Cast001_Den_#0224-W044	Niskin	2015	09	06	20:55	67	30.02	N	168	45.12	W	B-10
MR15-03_St005_Cast001_Den_#0225-W045	Niskin	2015	09	06	20:55	67	30.02	N	168	45.12	W	B-10
MR15-03_St006_Cast002_Den_#0226-W046	Bucket	2015	09	06	2:11	67	59.91	N	168	46.644	W	0
MR15-03_St006_Cast002_Den_#0227-W047	Niskin	2015	09	06	2:11	67	59.91	N	168	46.644	W	Chl-aMax
MR15-03_St006_Cast002_Den_#0228-W048	Niskin	2015	09	06	2:11	67	59.91	N	168	46.644	W	5
MR15-03_St006_Cast002_Den_#0229-W049	Niskin	2015	09	06	2:11	67	59.91	N	168	46.644	W	10
MR15-03_St006_Cast002_Den_#0230-W050	Niskin	2015	09	06	2:11	67	59.91	N	168	46.644	W	20
MR15-03_St006_Cast002_Den_#0231-W051	Niskin	2015	09	06	2:11	67	59.91	N	168	46.644	W	30
MR15-03_St006_Cast002_Den_#0232-W052	Niskin	2015	09	06	2:11	67	59.91	N	168	46.644	W	40
MR15-03_St006_Cast002_Den_#0233-W053	Niskin	2015	09	06	2:11	67	59.91	N	168	46.644	W	B-10
MR15-03_St006_Cast002_Den_#0234-W054	Niskin	2015	09	06	2:11	67	59.91	N	168	46.644	W	B-10
MR15-03_St007_Cast001_Den_#0235-W055	Bucket	2015	09	06	6:16	68	30.012	N	168	45.108	W	0
MR15-03_St007_Cast001_Den_#0236-W056	Niskin	2015	09	06	6:16	68	30.012	N	168	45.108	W	Chl-aMax
MR15-03_St007_Cast001_Den_#0237-W057	Niskin	2015	09	06	6:16	68	30.012	N	168	45.108	W	5
MR15-03_St007_Cast001_Den_#0238-W058	Niskin	2015	09	06	6:16	68	30.012	N	168	45.108	W	10
MR15-03_St007_Cast001_Den_#0239-W059	Niskin	2015	09	06	6:16	68	30.012	N	168	45.108	W	20
MR15-03_St007_Cast001_Den_#0240-W060	Niskin	2015	09	06	6:16	68	30.012	N	168	45.108	W	30
MR15-03_St007_Cast001_Den_#0241-W061	Niskin	2015	09	06	6:16	68	30.012	N	168	45.108	W	40
MR15-03_St007_Cast001_Den_#0242-W062	Niskin	2015	09	06	6:16	68	30.012	N	168	45.108	W	B-10
MR15-03_St007_Cast001_Den_#0243-W063	Niskin	2015	09	06	6:16	68	30.012	N	168	45.108	W	B-10
MR15-03_St008_Cast001_Den_#0244-W064	Bucket	2015	09	06	9:44	69	00.04	N	168	44.86	W	0
MR15-03_St008_Cast001_Den_#0245-W065	Niskin	2015	09	06	9:44	69	00.04	N	168	44.86	W	Chl-aMax
MR15-03_St008_Cast001_Den_#0246-W066	Niskin	2015	09	06	9:44	69	00.04	N	168	44.86	W	5
MR15-03_St008_Cast001_Den_#0247-W067	Niskin	2015	09	06	9:44	69	00.04	N	168	44.86	W	10
MR15-03_St008_Cast001_Den_#0248-W068	Niskin	2015	09	06	9:44	69	00.04	N	168	44.86	W	20
MR15-03_St008_Cast001_Den_#0249-W069	Niskin	2015	09	06	9:44	69	00.04	N	168	44.86	W	30
MR15-03_St008_Cast001_Den_#0250-W070	Niskin	2015	09	06	9:44	69	00.04	N	168	44.86	W	40
MR15-03_St008_Cast001_Den_#0251-W071	Niskin	2015	09	06	9:44	69	00.04	N	168	44.86	W	B-10
MR15-03_St008_Cast001_Den_#0252-W072	Niskin	2015	09	06	9:44	69	00.04	N	168	44.86	W	B-10

MR15-03_St009_Cast001_Den_#0253-W073	Bucket	2015	09	06	14:04	69	30.04	N	168	44.91	W	0
MR15-03_St009_Cast001_Den_#0254-W074	Niskin	2015	09	06	14:04	69	30.04	N	168	44.91	W	Chl-aMax
MR15-03_St009_Cast001_Den_#0255-W075	Niskin	2015	09	06	14:04	69	30.04	N	168	44.91	W	5
MR15-03_St009_Cast001_Den_#0256-W076	Niskin	2015	09	06	14:04	69	30.04	N	168	44.91	W	10
MR15-03_St009_Cast001_Den_#0257-W077	Niskin	2015	09	06	14:04	69	30.04	N	168	44.91	W	20
MR15-03_St009_Cast001_Den_#0258-W078	Niskin	2015	09	06	14:04	69	30.04	N	168	44.91	W	30
MR15-03_St009_Cast001_Den_#0259-W079	Niskin	2015	09	06	14:04	69	30.04	N	168	44.91	W	40
MR15-03_St009_Cast001_Den_#0260-W080	Niskin	2015	09	06	14:04	69	30.04	N	168	44.91	W	B-10
MR15-03_St009_Cast001_Den_#0261-W081	Niskin	2015	09	06	14:04	69	30.04	N	168	44.91	W	B-10
MR15-03_St010_Cast001_Den_#0262-W082	Bucket	2015	09	06	17:16	69	59.97	N	168	44.96	W	0
MR15-03_St010_Cast001_Den_#0263-W083	Niskin	2015	09	06	17:16	69	59.97	N	168	44.96	W	Chl-aMax
MR15-03_St010_Cast001_Den_#0264-W084	Niskin	2015	09	06	17:16	69	59.97	N	168	44.96	W	5
MR15-03_St010_Cast001_Den_#0265-W085	Niskin	2015	09	06	17:16	69	59.97	N	168	44.96	W	10
MR15-03_St010_Cast001_Den_#0266-W086	Niskin	2015	09	06	17:16	69	59.97	N	168	44.96	W	20
MR15-03_St010_Cast001_Den_#0267-W087	Niskin	2015	09	06	17:16	69	59.97	N	168	44.96	W	30
MR15-03_St010_Cast001_Den_#0268-W088	Niskin	2015	09	06	17:16	69	59.97	N	168	44.96	W	Not sampled
MR15-03_St010_Cast001_Den_#0269-W089	Niskin	2015	09	06	17:16	69	59.97	N	168	44.96	W	B-10
MR15-03_St010_Cast001_Den_#0270-W090	Niskin	2015	09	06	17:16	69	59.97	N	168	44.96	W	B-10
MR15-03_St011_Cast001_Den_#0271-W091	Bucket	2015	09	07	21:42	70	30.09	N	168	45.13	W	0
MR15-03_St011_Cast001_Den_#0272-W092	Niskin	2015	09	07	21:42	70	30.09	N	168	45.13	W	Chl-aMax
MR15-03_St011_Cast001_Den_#0273-W093	Niskin	2015	09	07	21:42	70	30.09	N	168	45.13	W	5
MR15-03_St011_Cast001_Den_#0274-W094	Niskin	2015	09	07	21:42	70	30.09	N	168	45.13	W	10
MR15-03_St011_Cast001_Den_#0275-W095	Niskin	2015	09	07	21:42	70	30.09	N	168	45.13	W	20
MR15-03_St011_Cast001_Den_#0276-W096	Niskin	2015	09	07	21:42	70	30.09	N	168	45.13	W	30
MR15-03_St011_Cast001_Den_#0278-W097	Niskin	2015	09	07	21:42	70	30.09	N	168	45.13	W	B-10
MR15-03_St011_Cast001_Den_#0279-W098	Niskin	2015	09	07	21:42	70	30.09	N	168	45.13	W	B-10
MR15-03_St012_Cast001_Den_#0277-W099	Bucket	2015	09	08	1:48	70	59.95	N	168	45.12	W	0
MR15-03_St012_Cast001_Den_#0280-W100	Niskin	2015	09	08	1:48	70	59.95	N	168	45.12	W	Chl-aMax
MR15-03_St012_Cast001_Den_#0281-W101	Niskin	2015	09	08	1:48	70	59.95	N	168	45.12	W	5
MR15-03_St012_Cast001_Den_#0282-W102	Niskin	2015	09	08	1:48	70	59.95	N	168	45.12	W	10
MR15-03_St012_Cast001_Den_#0283-W103	Niskin	2015	09	08	1:48	70	59.95	N	168	45.12	W	20
MR15-03_St012_Cast001_Den_#0284-W104	Niskin	2015	09	08	1:48	70	59.95	N	168	45.12	W	30
MR15-03_St012_Cast001_Den_#0285-W105	Niskin	2015	09	08	1:48	70	59.95	N	168	45.12	W	B-10
MR15-03_St012_Cast001_Den_#0286-W106	Niskin	2015	09	08	1:48	70	59.95	N	168	45.12	W	B-10
MR15-03_St015_Cast001_Den_#0287-W107	Bucket	2015	09	09	4:53	71	24.82	N	157	30.04	W	0
MR15-03_St015_Cast001_Den_#0288-W108	Niskin	2015	09	09	4:53	71	24.82	N	157	30.04	W	Chl-aMax
MR15-03_St015_Cast001_Den_#0289-W109	Niskin	2015	09	09	4:53	71	24.82	N	157	30.04	W	5
MR15-03_St015_Cast001_Den_#0290-W110	Niskin	2015	09	09	4:53	71	24.82	N	157	30.04	W	10

MR15-03_St015_Cast001_Den_#0291-W111	Niskin	2015	09	09	4:53	71	24.82	N	157	30.04	W	20
MR15-03_St015_Cast001_Den_#0292-W112	Niskin	2015	09	09	4:53	71	24.82	N	157	30.04	W	30
MR15-03_St015_Cast001_Den_#0293-W113	Niskin	2015	09	09	4:53	71	24.82	N	157	30.04	W	40
MR15-03_St015_Cast001_Den_#0294-W114	Niskin	2015	09	09	4:53	71	24.82	N	157	30.04	W	50
MR15-03_St015_Cast001_Den_#0295-W115	Niskin	2015	09	09	4:53	71	24.82	N	157	30.04	W	75
MR15-03_St015_Cast001_Den_#0296-W116	Niskin	2015	09	09	4:53	71	24.82	N	157	30.04	W	100
MR15-03_St015_Cast001_Den_#0297-W117	Niskin	2015	09	09	4:53	71	24.82	N	157	30.04	W	B-10
MR15-03_St015_Cast001_Den_#0298-W118	Niskin	2015	09	09	4:53	71	24.82	N	157	30.04	W	B-10
MR15-03_St022_Cast001_Den_#0299-W119	Bucket	2015	09	11	15:36	71	35.99	N	154	50.22	W	0
MR15-03_St022_Cast001_Den_#0300-W120	Niskin	2015	09	11	15:36	71	35.99	N	154	50.22	W	Chl-aMax
MR15-03_St022_Cast001_Den_#0301-W121	Niskin	2015	09	11	15:36	71	35.99	N	154	50.22	W	5
MR15-03_St022_Cast001_Den_#0302-W122	Niskin	2015	09	11	15:36	71	35.99	N	154	50.22	W	10
MR15-03_St022_Cast001_Den_#0303-W123	Niskin	2015	09	11	15:36	71	35.99	N	154	50.22	W	20
MR15-03_St022_Cast001_Den_#0304-W124	Niskin	2015	09	11	15:36	71	35.99	N	154	50.22	W	30
MR15-03_St022_Cast001_Den_#0305-W125	Niskin	2015	09	11	15:36	71	35.99	N	154	50.22	W	B-10
MR15-03_St022_Cast001_Den_#0306-W126	Niskin	2015	09	11	15:36	71	35.99	N	154	50.22	W	B-10
MR15-03_St023_Cast001_Den_#0307-W127	Bucket	2015	09	11	18:28	71	44.44	N	155	12.65	W	0
MR15-03_St023_Cast001_Den_#0308-W128	Niskin	2015	09	11	18:28	71	44.44	N	155	12.65	W	Chl-aMax
MR15-03_St023_Cast001_Den_#0309-W129	Niskin	2015	09	11	18:28	71	44.44	N	155	12.65	W	5
MR15-03_St023_Cast001_Den_#0310-W130	Niskin	2015	09	11	18:28	71	44.44	N	155	12.65	W	10
MR15-03_St023_Cast001_Den_#0311-W131	Niskin	2015	09	11	18:28	71	44.44	N	155	12.65	W	20
MR15-03_St023_Cast001_Den_#0312-W132	Niskin	2015	09	11	18:28	71	44.44	N	155	12.65	W	30
MR15-03_St023_Cast001_Den_#0313-W133	Niskin	2015	09	11	18:28	71	44.44	N	155	12.65	W	40
MR15-03_St023_Cast001_Den_#0314-W134	Niskin	2015	09	11	18:28	71	44.44	N	155	12.65	W	50
MR15-03_St023_Cast001_Den_#0315-W135	Niskin	2015	09	11	18:28	71	44.44	N	155	12.65	W	75
MR15-03_St023_Cast001_Den_#0316-W136	Niskin	2015	09	11	18:28	71	44.44	N	155	12.65	W	100
MR15-03_St023_Cast001_Den_#0317-W137	Niskin	2015	09	11	18:28	71	44.44	N	155	12.65	W	125
MR15-03_St023_Cast001_Den_#0318-W138	Niskin	2015	09	11	18:28	71	44.44	N	155	12.65	W	150
MR15-03_St023_Cast001_Den_#0319-W139	Niskin	2015	09	11	18:28	71	44.44	N	155	12.65	W	Data lost
MR15-03_St023_Cast001_Den_#0320-W140	Niskin	2015	09	11	18:28	71	44.44	N	155	12.65	W	Data lost
MR15-03_St023_Cast001_Den_#0321-W141	Niskin	2015	09	11	18:28	71	44.44	N	155	12.65	W	Data lost
MR15-03_St023_Cast001_Den_#0322-W142	Niskin	2015	09	11	18:28	71	44.44	N	155	12.65	W	Data lost
MR15-03_St023_Cast001_Den_#0323-W143	Niskin	2015	09	11	18:28	71	44.44	N	155	12.65	W	Data lost
MR15-03_St023_Cast001_Den_#0324-W144	Niskin	2015	09	11	18:28	71	44.44	N	155	12.65	W	Data lost
MR15-03_St024_Cast001_Den_#0325-W145	Bucket	2015	09	11	22:45	71	52.67	N	156	01.78	W	Data lost
MR15-03_St024_Cast001_Den_#0326-W146	Niskin	2015	09	11	22:45	71	52.67	N	156	01.78	W	Data lost
MR15-03_St024_Cast001_Den_#0327-W147	Niskin	2015	09	11	22:45	71	52.67	N	156	01.78	W	Data lost
MR15-03_St024_Cast001_Den_#0328-W148	Niskin	2015	09	11	22:45	71	52.67	N	156	01.78	W	Data lost

MR15-03_St024_Cast001_Den_#0329-W149	Niskin	2015	09	11	22:45	71	52.67	N	156	01.78	W	Data lost
MR15-03_St024_Cast001_Den_#0330-W150	Niskin	2015	09	11	22:45	71	52.67	N	156	01.78	W	Data lost
MR15-03_St024_Cast001_Den_#0331-W151	Niskin	2015	09	11	22:45	71	52.67	N	156	01.78	W	Data lost
MR15-03_St024_Cast001_Den_#0332-W152	Niskin	2015	09	11	22:45	71	52.67	N	156	01.78	W	Data lost
MR15-03_St024_Cast001_Den_#0333-W153	Niskin	2015	09	11	22:45	71	52.67	N	156	01.78	W	Data lost
MR15-03_St024_Cast001_Den_#0334-W154	Niskin	2015	09	11	22:45	71	52.67	N	156	01.78	W	Data lost
MR15-03_St025_Cast001_Den_#0335-W155	Bucket	2015	09	12	1:23	71	49.50	N	155	50.76	W	0
MR15-03_St025_Cast001_Den_#0336-W156	Niskin	2015	09	12	1:23	71	49.50	N	155	50.76	W	Chl-aMax
MR15-03_St025_Cast001_Den_#0337-W157	Niskin	2015	09	12	1:23	71	49.50	N	155	50.76	W	5
MR15-03_St025_Cast001_Den_#0338-W158	Niskin	2015	09	12	1:23	71	49.50	N	155	50.76	W	10
MR15-03_St025_Cast001_Den_#0339-W159	Niskin	2015	09	12	1:23	71	49.50	N	155	50.76	W	20
MR15-03_St025_Cast001_Den_#0340-W160	Niskin	2015	09	12	1:23	71	49.50	N	155	50.76	W	30
MR15-03_St025_Cast001_Den_#0341-W161	Niskin	2015	09	12	1:23	71	49.50	N	155	50.76	W	40
MR15-03_St025_Cast001_Den_#0342-W162	Niskin	2015	09	12	1:23	71	49.50	N	155	50.76	W	50
MR15-03_St025_Cast001_Den_#0343-W163	Niskin	2015	09	12	1:23	71	49.50	N	155	50.76	W	75
MR15-03_St025_Cast001_Den_#0344-W164	Niskin	2015	09	12	1:23	71	49.50	N	155	50.76	W	B-10
MR15-03_St025_Cast001_Den_#0345-W165	Niskin	2015	09	12	1:23	71	49.50	N	155	50.76	W	B-10
MR15-03_St026_Cast001_Den_#0346-W166	Bucket	2015	09	12	3:50	71	48.26	N	155	22.71	W	0
MR15-03_St026_Cast001_Den_#0347-W167	Niskin	2015	09	12	3:50	71	48.26	N	155	22.71	W	Chl-aMax
MR15-03_St026_Cast001_Den_#0348-W168	Niskin	2015	09	12	3:50	71	48.26	N	155	22.71	W	5
MR15-03_St026_Cast001_Den_#0349-W169	Niskin	2015	09	12	3:50	71	48.26	N	155	22.71	W	10
MR15-03_St026_Cast001_Den_#0350-W170	Niskin	2015	09	12	3:50	71	48.26	N	155	22.71	W	20
MR15-03_St026_Cast001_Den_#0351-W171	Niskin	2015	09	12	3:50	71	48.26	N	155	22.71	W	30
MR15-03_St026_Cast001_Den_#0352-W172	Niskin	2015	09	12	3:50	71	48.26	N	155	22.71	W	40
MR15-03_St026_Cast001_Den_#0353-W173	Niskin	2015	09	12	3:50	71	48.26	N	155	22.71	W	50
MR15-03_St026_Cast001_Den_#0354-W174	Niskin	2015	09	12	3:50	71	48.26	N	155	22.71	W	75
MR15-03_St026_Cast001_Den_#0355-W175	Niskin	2015	09	12	3:50	71	48.26	N	155	22.71	W	Data lost
MR15-03_St026_Cast001_Den_#0356-W176	Niskin	2015	09	12	3:50	71	48.26	N	155	22.71	W	125
MR15-03_St026_Cast001_Den_#0357-W177	Niskin	2015	09	12	3:50	71	48.26	N	155	22.71	W	B-10
MR15-03_St026_Cast001_Den_#0358-W178	Niskin	2015	09	12	3:50	71	48.26	N	155	22.71	W	B-10
MR15-03_St027_Cast001_Den_#0359-W179	Niskin	2015	09	12	7:01	71	39.95	N	155	01.41	W	100
MR15-03_St027_Cast001_Den_#0360-W180	Bucket	2015	09	12	7:01	71	39.95	N	155	01.41	W	0
MR15-03_St027_Cast001_Den_#0721-W181	Niskin	2015	09	12	7:01	71	39.95	N	155	01.41	W	Chl-aMax
MR15-03_St027_Cast001_Den_#0722-W182	Niskin	2015	09	12	7:01	71	39.95	N	155	01.41	W	5
MR15-03_St027_Cast001_Den_#0723-W183	Niskin	2015	09	12	7:01	71	39.95	N	155	01.41	W	10
MR15-03_St027_Cast001_Den_#0724-W184	Niskin	2015	09	12	7:01	71	39.95	N	155	01.41	W	20
MR15-03_St027_Cast001_Den_#0725-W185	Niskin	2015	09	12	7:01	71	39.95	N	155	01.41	W	30
MR15-03_St027_Cast001_Den_#0726-W186	Niskin	2015	09	12	7:01	71	39.95	N	155	01.41	W	40

MR15-03_St027_Cast001_Den_#0727-W187	Niskin	2015	09	12	7:01	71	39.95	N	155	01.41	W	50
MR15-03_St027_Cast001_Den_#0728-W188	Niskin	2015	09	12	7:01	71	39.95	N	155	01.41	W	75
MR15-03_St027_Cast001_Den_#0729-W189	Niskin	2015	09	12	7:01	71	39.95	N	155	01.41	W	B-10
MR15-03_St027_Cast001_Den_#0730-W190	Niskin	2015	09	12	7:01	71	39.95	N	155	01.41	W	B-10
MR15-03_St028_Cast001_Den_#0731-W191	Bucket	2015	09	12	16:18	72	00.06	N	157	28.04	W	0
MR15-03_St028_Cast001_Den_#0732-W192	Niskin	2015	09	12	16:18	72	00.06	N	157	28.04	W	Chl-aMax
MR15-03_St028_Cast001_Den_#0733-W193	Niskin	2015	09	12	16:18	72	00.06	N	157	28.04	W	5
MR15-03_St028_Cast001_Den_#0734-W194	Niskin	2015	09	12	16:18	72	00.06	N	157	28.04	W	10
MR15-03_St028_Cast001_Den_#0735-W195	Niskin	2015	09	12	16:18	72	00.06	N	157	28.04	W	20
MR15-03_St028_Cast001_Den_#0736-W196	Niskin	2015	09	12	16:18	72	00.06	N	157	28.04	W	30
MR15-03_St028_Cast001_Den_#0737-W197	Niskin	2015	09	12	16:18	72	00.06	N	157	28.04	W	40
MR15-03_St028_Cast001_Den_#0738-W198	Niskin	2015	09	12	16:18	72	00.06	N	157	28.04	W	50
MR15-03_St028_Cast001_Den_#0739-W199	Niskin	2015	09	12	16:18	72	00.06	N	157	28.04	W	Not sampled
MR15-03_St028_Cast001_Den_#0740-W200	Niskin	2015	09	12	16:18	72	00.06	N	157	28.04	W	B-10
MR15-03_St028_Cast001_Den_#0741-W201	Niskin	2015	09	12	16:18	72	00.06	N	157	28.04	W	B-10
MR15-03_St029_Cast001_Den_#0742-W202	Bucket	2015	09	12	18:44	72	07.94	N	156	58.04	W	0
MR15-03_St029_Cast001_Den_#0743-W203	Niskin	2015	09	12	18:44	72	07.94	N	156	58.04	W	Chl-aMax
MR15-03_St029_Cast001_Den_#0744-W204	Niskin	2015	09	12	18:44	72	07.94	N	156	58.04	W	5
MR15-03_St029_Cast001_Den_#0745-W205	Niskin	2015	09	12	18:44	72	07.94	N	156	58.04	W	10
MR15-03_St029_Cast001_Den_#0746-W206	Niskin	2015	09	12	18:44	72	07.94	N	156	58.04	W	20
MR15-03_St029_Cast001_Den_#0747-W207	Niskin	2015	09	12	18:44	72	07.94	N	156	58.04	W	30
MR15-03_St029_Cast001_Den_#0748-W208	Niskin	2015	09	12	18:44	72	07.94	N	156	58.04	W	40
MR15-03_St029_Cast001_Den_#0749-W209	Niskin	2015	09	12	18:44	72	07.94	N	156	58.04	W	50
MR15-03_St029_Cast001_Den_#0750-W210	Niskin	2015	09	12	18:44	72	07.94	N	156	58.04	W	75
MR15-03_St029_Cast001_Den_#0751-W211	Niskin	2015	09	12	18:44	72	07.94	N	156	58.04	W	100
MR15-03_St029_Cast001_Den_#0752-W212	Niskin	2015	09	12	18:44	72	07.94	N	156	58.04	W	Not sampled
MR15-03_St029_Cast001_Den_#0753-W213	Niskin	2015	09	12	18:44	72	07.94	N	156	58.04	W	B-10
MR15-03_St029_Cast001_Den_#0754-W214	Niskin	2015	09	12	18:44	72	07.94	N	156	58.04	W	B-10
MR15-03_St030_Cast001_Den_#0755-W215	Bucket	2015	09	12	20:55	72	17.34	N	156	42.13	W	0
MR15-03_St030_Cast001_Den_#0756-W216	Niskin	2015	09	12	20:55	72	17.34	N	156	42.13	W	Chl-aMax
MR15-03_St030_Cast001_Den_#0757-W217	Niskin	2015	09	12	20:55	72	17.34	N	156	42.13	W	5
MR15-03_St030_Cast001_Den_#0758-W218	Niskin	2015	09	12	20:55	72	17.34	N	156	42.13	W	10
MR15-03_St030_Cast001_Den_#0759-W219	Niskin	2015	09	12	20:55	72	17.34	N	156	42.13	W	20
MR15-03_St030_Cast001_Den_#0760-W220	Niskin	2015	09	12	20:55	72	17.34	N	156	42.13	W	30
MR15-03_St030_Cast001_Den_#0761-W221	Niskin	2015	09	12	20:55	72	17.34	N	156	42.13	W	40
MR15-03_St030_Cast001_Den_#0762-W222	Niskin	2015	09	12	20:55	72	17.34	N	156	42.13	W	50
MR15-03_St030_Cast001_Den_#0763-W223	Niskin	2015	09	12	20:55	72	17.34	N	156	42.13	W	75
MR15-03_St030_Cast001_Den_#0764-W224	Niskin	2015	09	12	20:55	72	17.34	N	156	42.13	W	100

MR15-03_St030_Cast001_Den_#0765-W225	Niskin	2015	09	12	20:55	72	17.34	N	156	42.13	W	125
MR15-03_St030_Cast001_Den_#0766-W226	Niskin	2015	09	12	20:55	72	17.34	N	156	42.13	W	150
MR15-03_St030_Cast001_Den_#0767-W227	Niskin	2015	09	12	20:55	72	17.34	N	156	42.13	W	175
MR15-03_St030_Cast001_Den_#0768-W228	Niskin	2015	09	12	20:55	72	17.34	N	156	42.13	W	200
MR15-03_St030_Cast001_Den_#0769-W229	Niskin	2015	09	12	20:55	72	17.34	N	156	42.13	W	225
MR15-03_St030_Cast001_Den_#0770-W230	Niskin	2015	09	12	20:55	72	17.34	N	156	42.13	W	250
MR15-03_St030_Cast001_Den_#0771-W231	Niskin	2015	09	12	20:55	72	17.34	N	156	42.13	W	Not sampled
MR15-03_St030_Cast001_Den_#0772-W232	Niskin	2015	09	12	20:55	72	17.34	N	156	42.13	W	Not sampled
MR15-03_St030_Cast001_Den_#0773-W233	Niskin	2015	09	12	20:55	72	17.34	N	156	42.13	W	Not sampled
MR15-03_St030_Cast001_Den_#0774-W234	Niskin	2015	09	12	20:55	72	17.34	N	156	42.13	W	Not sampled
MR15-03_St030_Cast001_Den_#0775-W235	Niskin	2015	09	12	20:55	72	17.34	N	156	42.13	W	B-10
MR15-03_St030_Cast001_Den_#0776-W236	Niskin	2015	09	12	20:55	72	17.34	N	156	42.13	W	B-10
MR15-03_St031_Cast001_Den_#0777-W237	Bucket	2015	09	13	19:36	72	06.21	N	154	40.63	W	0
MR15-03_St031_Cast001_Den_#0778-W238	Niskin	2015	09	13	19:36	72	06.21	N	154	40.63	W	Chl-aMax
MR15-03_St031_Cast001_Den_#0779-W239	Niskin	2015	09	13	19:36	72	06.21	N	154	40.63	W	5
MR15-03_St031_Cast001_Den_#0780-W240	Niskin	2015	09	13	19:36	72	06.21	N	154	40.63	W	10
MR15-03_St031_Cast001_Den_#0781-W241	Niskin	2015	09	13	19:36	72	06.21	N	154	40.63	W	20
MR15-03_St031_Cast001_Den_#0782-W242	Niskin	2015	09	13	19:36	72	06.21	N	154	40.63	W	30
MR15-03_St031_Cast001_Den_#0783-W243	Niskin	2015	09	13	19:36	72	06.21	N	154	40.63	W	40
MR15-03_St031_Cast001_Den_#0784-W244	Niskin	2015	09	13	19:36	72	06.21	N	154	40.63	W	50
MR15-03_St031_Cast001_Den_#0785-W245	Niskin	2015	09	13	19:36	72	06.21	N	154	40.63	W	75
MR15-03_St031_Cast001_Den_#0786-W246	Niskin	2015	09	13	19:36	72	06.21	N	154	40.63	W	100
MR15-03_St031_Cast001_Den_#0787-W247	Niskin	2015	09	13	19:36	72	06.21	N	154	40.63	W	125
MR15-03_St031_Cast001_Den_#0788-W248	Niskin	2015	09	13	19:36	72	06.21	N	154	40.63	W	150
MR15-03_St031_Cast001_Den_#0789-W249	Niskin	2015	09	13	19:36	72	06.21	N	154	40.63	W	175
MR15-03_St031_Cast001_Den_#0790-W250	Niskin	2015	09	13	19:36	72	06.21	N	154	40.63	W	200
MR15-03_St031_Cast001_Den_#0791-W251	Niskin	2015	09	13	19:36	72	06.21	N	154	40.63	W	225
MR15-03_St031_Cast001_Den_#0792-W252	Niskin	2015	09	13	19:36	72	06.21	N	154	40.63	W	250
MR15-03_St031_Cast001_Den_#0793-W253	Niskin	2015	09	13	19:36	72	06.21	N	154	40.63	W	300
MR15-03_St031_Cast001_Den_#0794-W254	Niskin	2015	09	13	19:36	72	06.21	N	154	40.63	W	400
MR15-03_St031_Cast001_Den_#0795-W255	Niskin	2015	09	13	19:36	72	06.21	N	154	40.63	W	500
MR15-03_St031_Cast001_Den_#0796-W256	Niskin	2015	09	13	19:36	72	06.21	N	154	40.63	W	600
MR15-03_St031_Cast001_Den_#0797-W257	Niskin	2015	09	13	19:36	72	06.21	N	154	40.63	W	800
MR15-03_St031_Cast001_Den_#0798-W258	Niskin	2015	09	13	19:36	72	06.21	N	154	40.63	W	1000
MR15-03_St031_Cast001_Den_#0799-W259	Niskin	2015	09	13	19:36	72	06.21	N	154	40.63	W	B-10
MR15-03_St031_Cast001_Den_#0800-W260	Niskin	2015	09	13	19:36	72	06.21	N	154	40.63	W	B-10
MR15-03_St032_Cast001_Den_#0801-W261	Bucket	2015	09	13	23:10	71	59.99	N	154	42.40	W	0
MR15-03_St032_Cast001_Den_#0802-W262	Niskin	2015	09	13	23:10	71	59.99	N	154	42.40	W	Chl-aMax

MR15-03_St032_Cast001_Den_#0803-W263	Niskin	2015	09	13	23:10	71	59.99	N	154	42.40	W	5
MR15-03_St032_Cast001_Den_#0804-W264	Niskin	2015	09	13	23:10	71	59.99	N	154	42.40	W	10
MR15-03_St032_Cast001_Den_#0805-W265	Niskin	2015	09	13	23:10	71	59.99	N	154	42.40	W	20
MR15-03_St032_Cast001_Den_#0806-W266	Niskin	2015	09	13	23:10	71	59.99	N	154	42.40	W	30
MR15-03_St032_Cast001_Den_#0807-W267	Niskin	2015	09	13	23:10	71	59.99	N	154	42.40	W	40
MR15-03_St032_Cast001_Den_#0808-W268	Niskin	2015	09	13	23:10	71	59.99	N	154	42.40	W	50
MR15-03_St032_Cast001_Den_#0809-W269	Niskin	2015	09	13	23:10	71	59.99	N	154	42.40	W	75
MR15-03_St032_Cast001_Den_#0810-W270	Niskin	2015	09	13	23:10	71	59.99	N	154	42.40	W	100
MR15-03_St032_Cast001_Den_#0811-W271	Niskin	2015	09	13	23:10	71	59.99	N	154	42.40	W	125
MR15-03_St032_Cast001_Den_#0812-W272	Niskin	2015	09	13	23:10	71	59.99	N	154	42.40	W	150
MR15-03_St032_Cast001_Den_#0813-W273	Niskin	2015	09	13	23:10	71	59.99	N	154	42.40	W	175
MR15-03_St032_Cast001_Den_#0814-W274	Niskin	2015	09	13	23:10	71	59.99	N	154	42.40	W	200
MR15-03_St032_Cast001_Den_#0815-W275	Niskin	2015	09	13	23:10	71	59.99	N	154	42.40	W	225
MR15-03_St032_Cast001_Den_#0816-W276	Niskin	2015	09	13	23:10	71	59.99	N	154	42.40	W	250
MR15-03_St032_Cast001_Den_#0817-W277	Niskin	2015	09	13	23:10	71	59.99	N	154	42.40	W	300
MR15-03_St032_Cast001_Den_#0818-W278	Niskin	2015	09	13	23:10	71	59.99	N	154	42.40	W	400
MR15-03_St032_Cast001_Den_#0819-W279	Niskin	2015	09	13	23:10	71	59.99	N	154	42.40	W	500
MR15-03_St032_Cast001_Den_#0822-W280	Niskin	2015	09	13	23:10	71	59.99	N	154	42.40	W	600
MR15-03_St032_Cast001_Den_#0823-W281	Niskin	2015	09	13	23:10	71	59.99	N	154	42.40	W	800
MR15-03_St032_Cast001_Den_#0824-W282	Niskin	2015	09	13	23:10	71	59.99	N	154	42.40	W	1000
MR15-03_St032_Cast001_Den_#0820-W283	Niskin	2015	09	13	23:10	71	59.99	N	154	42.40	W	B-10
MR15-03_St032_Cast001_Den_#0821-W284	Niskin	2015	09	13	23:10	71	59.99	N	154	42.40	W	B-10
MR15-03_St033_Cast001_Den_#0825-W285	Bucket	2015	09	14	3:17	71	55.03	N	154	58.31	W	0
MR15-03_St033_Cast001_Den_#0826-W286	Niskin	2015	09	14	3:17	71	55.03	N	154	58.31	W	Chl-aMax
MR15-03_St033_Cast001_Den_#0827-W287	Niskin	2015	09	14	3:17	71	55.03	N	154	58.31	W	5
MR15-03_St033_Cast001_Den_#0828-W288	Niskin	2015	09	14	3:17	71	55.03	N	154	58.31	W	10
MR15-03_St033_Cast001_Den_#0829-W289	Niskin	2015	09	14	3:17	71	55.03	N	154	58.31	W	20
MR15-03_St033_Cast001_Den_#0830-W290	Niskin	2015	09	14	3:17	71	55.03	N	154	58.31	W	30
MR15-03_St033_Cast001_Den_#0831-W291	Niskin	2015	09	14	3:17	71	55.03	N	154	58.31	W	40
MR15-03_St033_Cast001_Den_#0832-W292	Niskin	2015	09	14	3:17	71	55.03	N	154	58.31	W	50
MR15-03_St033_Cast001_Den_#0833-W293	Niskin	2015	09	14	3:17	71	55.03	N	154	58.31	W	75
MR15-03_St033_Cast001_Den_#0834-W294	Niskin	2015	09	14	3:17	71	55.03	N	154	58.31	W	100
MR15-03_St033_Cast001_Den_#0835-W295	Niskin	2015	09	14	3:17	71	55.03	N	154	58.31	W	125
MR15-03_St033_Cast001_Den_#0836-W296	Niskin	2015	09	14	3:17	71	55.03	N	154	58.31	W	150
MR15-03_St033_Cast001_Den_#0837-W297	Niskin	2015	09	14	3:17	71	55.03	N	154	58.31	W	175
MR15-03_St033_Cast001_Den_#0838-W298	Niskin	2015	09	14	3:17	71	55.03	N	154	58.31	W	200
MR15-03_St033_Cast001_Den_#0839-W299	Niskin	2015	09	14	3:17	71	55.03	N	154	58.31	W	225
MR15-03_St033_Cast001_Den_#0840-W300	Niskin	2015	09	14	3:17	71	55.03	N	154	58.31	W	250

MR15-03_St033_Cast001_Den_#0841-W301	Niskin	2015	09	14	3:17	71	55.03	N	154	58.31	W	300
MR15-03_St033_Cast001_Den_#0842-W302	Niskin	2015	09	14	3:17	71	55.03	N	154	58.31	W	B-10
MR15-03_St033_Cast001_Den_#0843-W303	Niskin	2015	09	14	3:17	71	55.03	N	154	58.31	W	B-10
MR15-03_St039_Cast002_Den_#0844-W304	Bucket	2015	09	14	1:28	72	23.48	N	155	24.15	W	0
MR15-03_St039_Cast002_Den_#0845-W305	Niskin	2015	09	14	1:28	72	23.48	N	155	24.15	W	Chl-aMax
MR15-03_St039_Cast002_Den_#0846-W306	Niskin	2015	09	14	1:28	72	23.48	N	155	24.15	W	5
MR15-03_St039_Cast002_Den_#0847-W307	Niskin	2015	09	14	1:28	72	23.48	N	155	24.15	W	10
MR15-03_St039_Cast002_Den_#0848-W308	Niskin	2015	09	14	1:28	72	23.48	N	155	24.15	W	20
MR15-03_St039_Cast002_Den_#0849-W309	Niskin	2015	09	14	1:28	72	23.48	N	155	24.15	W	30
MR15-03_St039_Cast002_Den_#0850-W310	Niskin	2015	09	14	1:28	72	23.48	N	155	24.15	W	40
MR15-03_St039_Cast002_Den_#0851-W311	Niskin	2015	09	14	1:28	72	23.48	N	155	24.15	W	50
MR15-03_St039_Cast002_Den_#0852-W312	Niskin	2015	09	14	1:28	72	23.48	N	155	24.15	W	75
MR15-03_St039_Cast002_Den_#0853-W313	Niskin	2015	09	14	1:28	72	23.48	N	155	24.15	W	100
MR15-03_St039_Cast002_Den_#0854-W314	Niskin	2015	09	14	1:28	72	23.48	N	155	24.15	W	125
MR15-03_St039_Cast002_Den_#0855-W315	Niskin	2015	09	14	1:28	72	23.49	N	155	24.15	W	150
MR15-03_St039_Cast002_Den_#0856-W316	Niskin	2015	09	14	1:28	72	23.50	N	155	24.15	W	175
MR15-03_St039_Cast002_Den_#0857-W317	Niskin	2015	09	14	1:28	72	23.51	N	155	24.15	W	200
MR15-03_St039_Cast002_Den_#0858-W318	Niskin	2015	09	14	1:28	72	23.52	N	155	24.15	W	225
MR15-03_St039_Cast002_Den_#0859-W319	Niskin	2015	09	14	1:28	72	23.53	N	155	24.15	W	250
MR15-03_St039_Cast002_Den_#0860-W320	Niskin	2015	09	14	1:28	72	23.54	N	155	24.15	W	300
MR15-03_St039_Cast002_Den_#0861-W321	Niskin	2015	09	14	1:28	72	23.55	N	155	24.15	W	400
MR15-03_St039_Cast002_Den_#0862-W322	Niskin	2015	09	14	1:28	72	23.56	N	155	24.15	W	500
MR15-03_St039_Cast002_Den_#0863-W323	Niskin	2015	09	14	1:28	72	23.57	N	155	24.15	W	600
MR15-03_St039_Cast002_Den_#0864-W324	Niskin	2015	09	14	1:28	72	23.58	N	155	24.15	W	800
MR15-03_St039_Cast002_Den_#0865-W325	Niskin	2015	09	14	1:28	72	23.59	N	155	24.15	W	1000
MR15-03_St039_Cast002_Den_#0866-W326	Niskin	2015	09	14	1:28	72	23.60	N	155	24.15	W	Not sampled
MR15-03_St039_Cast002_Den_#0867-W327	Niskin	2015	09	14	1:28	72	23.61	N	155	24.15	W	B-10
MR15-03_St039_Cast002_Den_#0868-W328	Niskin	2015	09	14	1:28	72	23.62	N	155	24.15	W	B-10
MR15-03_St040_Cast001_Den_#0869-W329	Bucket	2015	09	14	5:11	72	26.19	N	156	35.45	W	0
MR15-03_St040_Cast001_Den_#0870-W330	Niskin	2015	09	14	5:11	72	26.19	N	156	35.45	W	Chl-aMax
MR15-03_St040_Cast001_Den_#0871-W331	Niskin	2015	09	14	5:11	72	26.19	N	156	35.45	W	5
MR15-03_St040_Cast001_Den_#0872-W332	Niskin	2015	09	14	5:11	72	26.19	N	156	35.45	W	10
MR15-03_St040_Cast001_Den_#0873-W333	Niskin	2015	09	14	5:11	72	26.19	N	156	35.45	W	20
MR15-03_St040_Cast001_Den_#0874-W334	Niskin	2015	09	14	5:11	72	26.19	N	156	35.45	W	30
MR15-03_St040_Cast001_Den_#0875-W335	Niskin	2015	09	14	5:11	72	26.19	N	156	35.45	W	40
MR15-03_St040_Cast001_Den_#0876-W336	Niskin	2015	09	14	5:11	72	26.19	N	156	35.45	W	50
MR15-03_St040_Cast001_Den_#0877-W337	Niskin	2015	09	14	5:11	72	26.19	N	156	35.45	W	75
MR15-03_St040_Cast001_Den_#0878-W338	Niskin	2015	09	14	5:11	72	26.19	N	156	35.45	W	100

MR15-03_St040_Cast001_Den_#0879-W339	Niskin	2015	09	14	5:11	72	26.19	N	156	35.45	W	125
MR15-03_St040_Cast001_Den_#0880-W340	Niskin	2015	09	14	5:11	72	26.19	N	156	35.45	W	150
MR15-03_St040_Cast001_Den_#0881-W341	Niskin	2015	09	14	5:11	72	26.19	N	156	35.45	W	175
MR15-03_St040_Cast001_Den_#0882-W342	Niskin	2015	09	14	5:11	72	26.19	N	156	35.45	W	200
MR15-03_St040_Cast001_Den_#0883-W343	Niskin	2015	09	14	5:11	72	26.19	N	156	35.45	W	225
MR15-03_St040_Cast001_Den_#0884-W344	Niskin	2015	09	14	5:11	72	26.19	N	156	35.45	W	250
MR15-03_St040_Cast001_Den_#0885-W345	Niskin	2015	09	14	5:11	72	26.19	N	156	35.45	W	300
MR15-03_St040_Cast001_Den_#0886-W346	Niskin	2015	09	14	5:11	72	26.19	N	156	35.45	W	400
MR15-03_St040_Cast001_Den_#0887-W347	Niskin	2015	09	14	5:11	72	26.19	N	156	35.45	W	500
MR15-03_St040_Cast001_Den_#0888-W348	Niskin	2015	09	14	5:11	72	26.19	N	156	35.45	W	600
MR15-03_St040_Cast001_Den_#0889-W349	Niskin	2015	09	14	5:11	72	26.19	N	156	35.45	W	800
MR15-03_St040_Cast001_Den_#0890-W350	Niskin	2015	09	14	5:11	72	26.19	N	156	35.45	W	B-10
MR15-03_St040_Cast001_Den_#0891-W351	Niskin	2015	09	14	5:11	72	26.19	N	156	35.45	W	B-10
MR15-03_St075_Cast001_Den_#0892-W352	Bucket	2015	09	25	0:45	73	12.53	N	157	48.22	W	0
MR15-03_St075_Cast001_Den_#0893-W353	Niskin	2015	09	25	0:45	73	12.53	N	157	48.22	W	Chl-aMax
MR15-03_St075_Cast001_Den_#0894-W354	Niskin	2015	09	25	0:45	73	12.53	N	157	48.22	W	5
MR15-03_St075_Cast001_Den_#0895-W355	Niskin	2015	09	25	0:45	73	12.53	N	157	48.22	W	10
MR15-03_St075_Cast001_Den_#0896-W356	Niskin	2015	09	25	0:45	73	12.53	N	157	48.22	W	20
MR15-03_St075_Cast001_Den_#0897-W357	Niskin	2015	09	25	0:45	73	12.53	N	157	48.22	W	30
MR15-03_St075_Cast001_Den_#0898-W358	Niskin	2015	09	25	0:45	73	12.53	N	157	48.22	W	40
MR15-03_St075_Cast001_Den_#0899-W359	Niskin	2015	09	25	0:45	73	12.53	N	157	48.22	W	50
MR15-03_St075_Cast001_Den_#0900-W360	Niskin	2015	09	25	0:45	73	12.53	N	157	48.22	W	75
MR15-03_St075_Cast001_Den_#0901-W361	Niskin	2015	09	25	0:45	73	12.53	N	157	48.22	W	100
MR15-03_St075_Cast001_Den_#0902-W362	Niskin	2015	09	25	0:45	73	12.53	N	157	48.22	W	125
MR15-03_St075_Cast001_Den_#0903-W363	Niskin	2015	09	25	0:45	73	12.53	N	157	48.22	W	150
MR15-03_St075_Cast001_Den_#0904-W364	Niskin	2015	09	25	0:45	73	12.53	N	157	48.22	W	175
MR15-03_St075_Cast001_Den_#0905-W365	Niskin	2015	09	25	0:45	73	12.53	N	157	48.22	W	200
MR15-03_St075_Cast001_Den_#0906-W366	Niskin	2015	09	25	0:45	73	12.53	N	157	48.22	W	250
MR15-03_St075_Cast001_Den_#0907-W367	Niskin	2015	09	25	0:45	73	12.53	N	157	48.22	W	300
MR15-03_St075_Cast001_Den_#0908-W368	Niskin	2015	09	25	0:45	73	12.53	N	157	48.22	W	400
MR15-03_St075_Cast001_Den_#0909-W369	Niskin	2015	09	25	0:45	73	12.53	N	157	48.22	W	500
MR15-03_St075_Cast001_Den_#0910-W370	Niskin	2015	09	25	0:45	73	12.53	N	157	48.22	W	600
MR15-03_St075_Cast001_Den_#0911-W371	Niskin	2015	09	25	0:45	73	12.53	N	157	48.22	W	800
MR15-03_St075_Cast001_Den_#0912-W372	Niskin	2015	09	25	0:45	73	12.53	N	157	48.22	W	1000
MR15-03_St075_Cast001_Den_#0913-W373	Niskin	2015	09	25	0:45	73	12.53	N	157	48.22	W	1500
MR15-03_St075_Cast001_Den_#0914-W374	Niskin	2015	09	25	0:45	73	12.53	N	157	48.22	W	2000
MR15-03_St075_Cast001_Den_#0915-W375	Niskin	2015	09	25	0:45	73	12.53	N	157	48.22	W	2500
MR15-03_St075_Cast001_Den_#0916-W376	Niskin	2015	09	25	0:45	73	12.53	N	157	48.22	W	B-10

MR15-03_St075_Cast001_Den_#0917-W377	Niskin	2015	09	25	0:45	73	12.53	N	157	48.22	W	B-10
MR15-03_St085_Cast002_Den_#0918-W378	Bucket	2015	09	26	19:52	73	18.61	N	160	45.60	W	0
MR15-03_St085_Cast002_Den_#0919-W379	Niskin	2015	09	26	19:52	73	18.61	N	160	45.60	W	Chl-aMax
MR15-03_St085_Cast002_Den_#0920-W380	Niskin	2015	09	26	19:52	73	18.61	N	160	45.60	W	5
MR15-03_St085_Cast002_Den_#0921-W381	Niskin	2015	09	26	19:52	73	18.61	N	160	45.60	W	10
MR15-03_St085_Cast002_Den_#0922-W382	Niskin	2015	09	26	19:52	73	18.61	N	160	45.60	W	20
MR15-03_St085_Cast002_Den_#0923-W383	Niskin	2015	09	26	19:52	73	18.61	N	160	45.60	W	30
MR15-03_St085_Cast002_Den_#0924-W384	Niskin	2015	09	26	19:52	73	18.61	N	160	45.60	W	40
MR15-03_St085_Cast002_Den_#0925-W385	Niskin	2015	09	26	19:52	73	18.61	N	160	45.60	W	50
MR15-03_St085_Cast002_Den_#0926-W386	Niskin	2015	09	26	19:52	73	18.61	N	160	45.60	W	75
MR15-03_St085_Cast002_Den_#0927-W387	Niskin	2015	09	26	19:52	73	18.61	N	160	45.60	W	100
MR15-03_St085_Cast002_Den_#0928-W388	Niskin	2015	09	26	19:52	73	18.61	N	160	45.60	W	125
MR15-03_St085_Cast002_Den_#0929-W389	Niskin	2015	09	26	19:52	73	18.61	N	160	45.60	W	150
MR15-03_St085_Cast002_Den_#0930-W390	Niskin	2015	09	26	19:52	73	18.61	N	160	45.60	W	175
MR15-03_St085_Cast002_Den_#0931-W391	Niskin	2015	09	26	19:52	73	18.61	N	160	45.60	W	200
MR15-03_St085_Cast002_Den_#0932-W392	Niskin	2015	09	26	19:52	73	18.61	N	160	45.60	W	225
MR15-03_St085_Cast002_Den_#0933-W393	Niskin	2015	09	26	19:52	73	18.61	N	160	45.60	W	250
MR15-03_St085_Cast002_Den_#0934-W394	Niskin	2015	09	26	19:52	73	18.61	N	160	45.60	W	300
MR15-03_St085_Cast002_Den_#0935-W395	Niskin	2015	09	26	19:52	73	18.61	N	160	45.60	W	400
MR15-03_St085_Cast002_Den_#0936-W396	Niskin	2015	09	26	19:52	73	18.61	N	160	45.60	W	B-10
MR15-03_St085_Cast002_Den_#0937-W397	Niskin	2015	09	26	19:52	73	18.61	N	160	45.60	W	B-10
MR15-03_St099_Cast001_Den_#0938-W398	Bucket	2015	09	29	0:54	74	30.02	N	168	45.11	W	0
MR15-03_St099_Cast001_Den_#0939-W399	Niskin	2015	09	29	0:54	74	30.02	N	168	45.11	W	Chl-aMax
MR15-03_St099_Cast001_Den_#0940-W400	Niskin	2015	09	29	0:54	74	30.02	N	168	45.11	W	5
MR15-03_St099_Cast001_Den_#0941-W401	Niskin	2015	09	29	0:54	74	30.02	N	168	45.11	W	10
MR15-03_St099_Cast001_Den_#0942-W402	Niskin	2015	09	29	0:54	74	30.02	N	168	45.11	W	20
MR15-03_St099_Cast001_Den_#0943-W403	Niskin	2015	09	29	0:54	74	30.02	N	168	45.11	W	30
MR15-03_St099_Cast001_Den_#0944-W404	Niskin	2015	09	29	0:54	74	30.02	N	168	45.11	W	40
MR15-03_St099_Cast001_Den_#0945-W405	Niskin	2015	09	29	0:54	74	30.02	N	168	45.11	W	50
MR15-03_St099_Cast001_Den_#0946-W406	Niskin	2015	09	29	0:54	74	30.02	N	168	45.11	W	75
MR15-03_St099_Cast001_Den_#0947-W407	Niskin	2015	09	29	0:54	74	30.02	N	168	45.11	W	100
MR15-03_St099_Cast001_Den_#0948-W408	Niskin	2015	09	29	0:54	74	30.02	N	168	45.11	W	125
MR15-03_St099_Cast001_Den_#0949-W409	Niskin	2015	09	29	0:54	74	30.02	N	168	45.11	W	150
MR15-03_St099_Cast001_Den_#0950-W410	Niskin	2015	09	29	0:54	74	30.02	N	168	45.11	W	175
MR15-03_St099_Cast001_Den_#0951-W411	Niskin	2015	09	29	0:54	74	30.02	N	168	45.11	W	B-10
MR15-03_St099_Cast001_Den_#0952-W412	Niskin	2015	09	29	0:54	74	30.02	N	168	45.11	W	B-10
MR15-03_St102_Cast001_Den_#0953-W413	Bucket	2015	09	29	22:20	72	00.11	N	168	44.74	W	0
MR15-03_St102_Cast001_Den_#0954-W414	Niskin	2015	09	29	22:20	72	00.11	N	168	44.74	W	10

MR15-03_St102_Cast001_Den_#0955-W415	Niskin	2015	09	29	22:20	72	00.11	N	168	44.74	W	20
MR15-03_St102_Cast001_Den_#0956-W416	Niskin	2015	09	29	22:20	72	00.11	N	168	44.74	W	30
MR15-03_St102_Cast001_Den_#0957-W417	Niskin	2015	09	29	22:20	72	00.11	N	168	44.74	W	40
MR15-03_St102_Cast001_Den_#0958-W418	Niskin	2015	09	29	22:20	72	00.11	N	168	44.74	W	Not sampled
MR15-03_St102_Cast001_Den_#0959-W419	Niskin	2015	09	29	22:20	72	00.11	N	168	44.74	W	B-10
MR15-03_St102_Cast001_Den_#0960-W420	Niskin	2015	09	29	22:20	72	00.11	N	168	44.74	W	B-10

3.9. Moorings

(1) Personnel

Motoyo Itoh	(JAMSTEC; not on board): Principal investigator
Jonaotaro Onodera	(JAMSTEC)
Shigeto Nishino	(JAMSTEC)
Yusuke Kawaguchi	(JAMSTEC)
Keisuke Matsumoto	(MWJ): Operation leader
Tomohide Noguchi	(MWJ)
Tatsuya Tanaka	(MWJ)
Rei Ito	(MWJ)
Keisuke Takeda	(MWJ)

(2) Objectives

We recovered five moorings (BCH-14, BCE-14, BCC-14, BCW-14 and SCH-14w). Unfortunately, we failed to recover and lost one mooring (SCH-14).

We deployed five moorings. Three moorings were deployed in the Barrow Canyon (BCW-15, BCE-15, and BCC-15) at the locations which were almost the same as those of the deployed moorings. Components of these moorings are depicted in Figure 3.9-1. In addition, two sediment trap moorings were deployed at the north of Barrow Canyon (NBC-15t) and north of Hanna Canyon (NHC-15t), both of which were set at new locations. Details of the sediment trap moorings are described in Section 4.21.

(3) Measured parameters

- Current velocities
- Echo intensity, bottom tracking range and velocities for sea ice measurements
- Pressure, temperature and conductivity
- Dissolved oxygen
- Chlorophyll *a* and turbidity

(4) Instruments

1) CTD or CT sensors

SBE37-SM (Sea-Bird Electronics Inc.)
SBE37-SMP-IDO (Sea-Bird Electronics Inc.)
A7CT-USB (JFE Advantech)

2) Current meters

Workhorse ADCP 300 kHz SC Sentinel (Teledyne RD Instruments, Inc.)
Aquadopp Current Meter 2MHz (NORTEK AS)
S4D current meter (InterOcean systems, Inc.)

3) Dissolved oxygen sensors
 AROW-USB (JFE Advantech)
 SBE37-SMP-IDO (Sea-Bird Electronics Inc.)

4) Chlorophyll *a* and turbidity sensors
 ACLW-USB (JFE Advantech)

5) Acoustic transponder
 XT-6000-10 (Teledyne Benthos, Inc.)

6) Acoustic releasers
 Model L-Ti (Nichiyu giken kogyo co., LTD)
 Model L-BL (Nichiyu giken kogyo co., LTD)
 8242XS (ORE offshore /EdgeTech)

(5) Station list

Table 3.9-1: Stations of deployed moorings

Mooring ID	Deployment Date [UTC]	Latitude [N]	Longitude [W]	Bottom depth [m]
BCE-15	2015/09/11	71-40.3609	154-59.7669	106
BCC-15	2015/09/10	71-44.0179	155-09.4950	283
BCW-15	2015/09/10	71-47.7452	155-20.8069	171
NBC-15t	2015/09/19	72-28.3173	155-22.9688	2,002
NHC-15t	2015/09/27	73-18.0766	160-46.8579	426

BCW-15

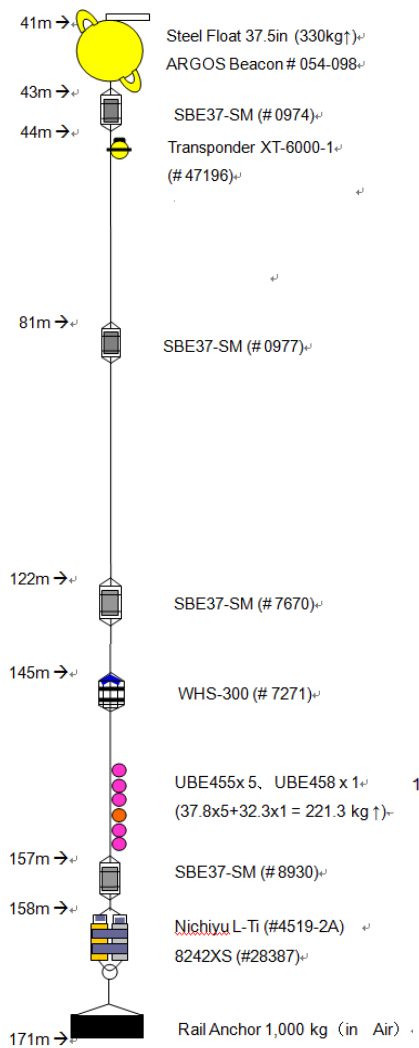

BCE-15

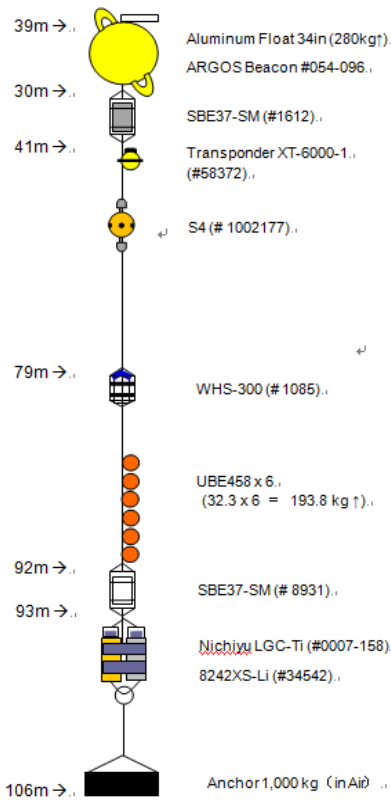

BCC-15

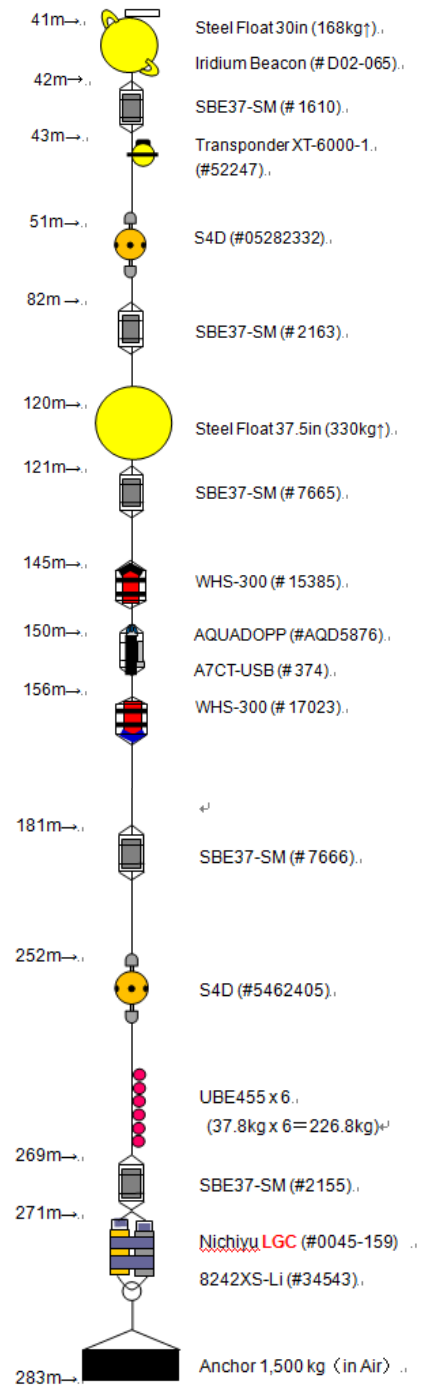

Figure 3.9-1: Diagrams of deployed moorings (BCW-15, BCE-15, and BCC-15).

4. Chemical and Biological Oceanography

4.1. Dissolved oxygen

(1) Personnel

Shigeto NISHINO (JAMSTEC): Principal Investigator

Haruka TAMADA (Marine Works Japan Co. Ltd): Operation Leader (Leg1)

Hironori SATO (Marine Works Japan Co. Ltd)

Yoshiki KIDO (Marine Works Japan Co. Ltd)

Shinichiro YOKOGAWA (Marine Works Japan Co. Ltd): Operation Leader (Leg2)

(2) Objective

Determination of dissolved oxygen in seawater by Winkler titration.

(3) Parameters

Dissolved Oxygen

(4) Instruments and Methods

Following procedure is based on an analytical method, entitled by “Determination of dissolved oxygen in sea water by Winkler titration”, in the WHP Operations and Methods (Dickson, 1996).

a. Instruments

Burette for sodium thiosulfate and potassium iodate;

APB-510 / APB-620 manufactured by Kyoto Electronic Co. Ltd. / 10 cm³ of titration vessel

Detector;

Automatic photometric titrator (DOT-01X) manufactured by Kimoto Electronic Co. Ltd.

Software;

DOT_Terminal Ver. 1.2.0

b. Reagents

Pickling Reagent I: Manganese chloride solution (3 mol dm⁻³)

Pickling Reagent II:

Sodium hydroxide (8 mol dm⁻³) / sodium iodide solution (4 mol dm⁻³)

Sulfuric acid solution (5 mol dm⁻³)

Sodium thiosulfate (0.025 mol dm⁻³)

Potassium iodide ($0.001667 \text{ mol dm}^{-3}$)

CSK standard of potassium iodide:

Lot KPG6393, Wako Pure Chemical Industries Ltd., 0.0100N

c. Sampling

Seawater samples were collected with Niskin bottle attached to the CTD-system and surface bucket sampler. Seawater for oxygen measurement was transferred from sampler to a volume calibrated flask (ca. 100 cm^3). Three times volume of the flask of seawater was overflowed. Temperature was measured by digital thermometer during the overflowing. Then two reagent solutions (Reagent I and II) of 0.5 cm^3 each were added immediately into the sample flask and the stopper was inserted carefully into the flask. The sample flask was then shaken vigorously to mix the contents and to disperse the precipitate finely throughout. After the precipitate has settled at least halfway down the flask, the flask was shaken again vigorously to disperse the precipitate. The sample flasks containing pickled samples were stored in a laboratory until they were titrated.

d. Sample measurement

At least two hours after the re-shaking, the pickled samples were measured on board. 1 cm^3 sulfuric acid solution and a magnetic stirrer bar were added into the sample flask and stirring began. Samples were titrated by sodium thiosulfate solution whose morality was determined by potassium iodate solution. Temperature of sodium thiosulfate during titration was recorded by a digital thermometer. During this cruise, we measured dissolved oxygen concentration using 2 sets of the titration apparatus. Dissolved oxygen concentration ($\mu\text{mol kg}^{-1}$) was calculated by sample temperature during seawater sampling, salinity of the bottle sampling, flask volume, and titrated volume of sodium thiosulfate solution without the blank.

e. Standardization and determination of the blank

Concentration of sodium thiosulfate titrant was determined by potassium iodate solution. Pure potassium iodate was dried in an oven at 130°C . 1.7835g potassium iodate weighed out accurately was dissolved in deionized water and diluted to final volume of 5 dm^3 in a calibrated volumetric flask ($0.001667 \text{ mol dm}^{-3}$). 10 cm^3 of the standard potassium iodate solution was added to a flask using a volume-calibrated dispenser. Then 90 cm^3 of deionized water, 1 cm^3 of sulfuric acid solution, and 0.5 cm^3 of pickling reagent solution II and I were added into the flask in order. Amount of titrated volume of sodium thiosulfate (usually 5 times measurements average) gave the morality

of sodium thiosulfate titrant.

The oxygen in the pickling reagents I (0.5 cm³) and II (0.5 cm³) was assumed to be 3.8 x 10⁻⁸ mol (Murray *et al.*, 1968). The blank due to other than oxygen was determined as follows. 1 and 2 cm³ of the standard potassium iodate solution were added to two flasks respectively using a calibrated dispenser. Then 100 cm³ of deionized water, 1 cm³ of sulfuric acid solution, and 0.5 cm³ of pickling reagent solution II and I each were added into the flask in order. The blank was determined by difference between the first (1 cm³ of KIO₃) titrated volume of the sodium thiosulfate and the second (2 cm³ of KIO₃) one. The results of 3 times blank determinations were averaged.

(5) Observation log

a. Standardization and determination of the blank

Table 4.1-1 shows results of the standardization and the blank determination during this cruise.

Table 4.1-1 Results of the standardization and the blank determinations during cruise.

Date	KIO ₃ ID	Na ₂ S ₂ O ₃	DOT-01X(No.7)		DOT-01X(No.8)		Stations
			E.P.	Blank	E.P.	Blank	
2015/08/28	CSK_KPG6393	T1505L	3.970	0.000	3.964	0.004	
2015/08/28	K1504B02	T1505L	3.966	0.000	3.960	0.004	
2015/08/29	K1504B03	T1505L	3.967	0.000	3.961	0.006	
2015/08/29	K1504B03	T1505L	3.958	0.002	3.959	0.004	
2015/08/29	K1504B03	T1505L	3.958	0.002	3.960	0.004	
2015/09/01	K1504B04	T1505L	3.959	0.003	3.963	0.004	001, 002, 003, 004, 005, 006(cast002), 007, 008, 009, 010, 011, 012
2015/09/08	K1504B05	T1505L	3.963	0.006	3.963	0.003	013, 014, 015, 016, 022, 023, 024, 025, 026, 027, 028, 029, 030, 031, 032
2015/9/14	K1504B06	T1505L	3.968	0.007	3.969	0.004	
2015/9/14	K1504B06	T1505M	3.964	0.005	3.962	-0.001	033, 035, 037, 039, 040, 045, 046, 047, 048, 049, 050, 051, 052, 053(cast004)
2015/9/17	K1504B07	T1505M	3.968	0.008	3.965	0.003	053(cast008, 012, 016), 054(cast002), 055, 056(cast004, 008, 010, 012, 016)

2015/9/22	K1504B08	T1505M	3.966	0.007	3.967	0.004	
2015/9/22	K1504B08	T1505N	3.964	0.007	3.965	0.003	060, 061, 062, 063, 064, 065, 066, 067, 068, 069, 070, 071, 072, 074, 075, 077, 081, 082, 083, 084, 085(cast002)
2015/9/27	CSK_KPG6393	T1505N	3.966	0.008	3.969	0.004	
2015/9/27	K1504C01	T1505N	3.963	0.008	3.966	0.004	
2015/9/27	K1504C01	T1505O	3.964	0.003	3.968	0.004	094, 095, 096, 098(cast002), 099, 100, 101, 102, 103, 104, 105, 106, 107, 108, 109
2015/10/4	K1504C02	T1505O	3.969	0.009	3.969	0.005	
2015/10/10	K1504C03	T1505O	---	---	3.970	0.006	
2015/10/11	K1504C04	T1505O	---	---	3.970	0.005	
2015/10/18	K1504C05	T1505O	---	---	3.971	0.006	

b. Repeatability of sample measurement

Replicate samples were taken at every CTD casts. Total amount of the replicate sample pairs of good measurement was 154. The standard deviation of the replicate measurement was 0.10 $\mu\text{mol kg}^{-1}$ that was calculated by a procedure in Guide to best practices for ocean CO₂ measurements Chapter4 SOP23 Ver.3.0 (2007). Results of replicate samples were shown in Table 4.1-2 and this diagram shown in Fig. 4.1-1.

Table 4.1-2 Results of the replicate sample measurements

Layer	Number of replicate sample pairs	Oxygen concentration ($\mu\text{mol kg}^{-1}$) Standard Deviation.
200m>	131	0.10
>=200m	23	0.10
All	154	0.10

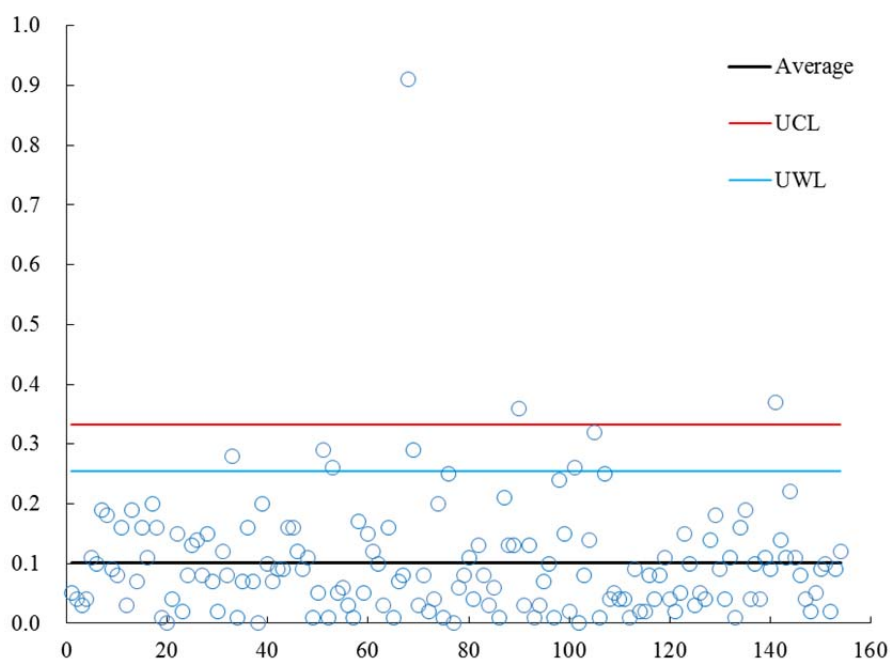

Fig. 4.1-1 Differences of replicate samples against sequence number

(6) Data archives

These data obtained in this cruise will be submitted to the Data Management Group of JAMSTEC, and will be opened to the public via “Data Research System for Whole Cruise Information in JAMSTEC (DARWIN)” in JAMSTEC web site.

<http://www.godac.jamstec.go.jp/darwin/e>

(7) References

Dickson, A.G., Determination of dissolved oxygen in sea water by Winkler titration. (1996)

Dickson, A.G., Sabine, C.L. and Christian, J.R. (Eds.), Guide to best practices for ocean CO₂ measurements. (2007)

Culberson, C.H., WHP Operations and Methods July-1991 “Dissolved Oxygen”, (1991)
Japan Meteorological Agency, Oceanographic research guidelines (Part 1). (1999)

KIMOTO electric CO. LTD., Automatic photometric titrator DOT-01 Instruction manual

4.2. Nutrients

(1) Personnel

Michio AOYAMA (JAMSTEC/Fukushima Univ.): Principal Investigator

Shigeto NISHINO (JAMSTEC)

Yasuhiro ARII (MWJ): Operation leader

Tomomi SONE (MWJ)

Elena HAYASHI (MWJ)

Shinichiro YOKOGWA (MWJ)

Masanori ENOKI (MWJ)

(2) Objectives

The objectives of nutrients analyses during the R/V Mirai MR15-03 cruise in the Arctic Ocean is as follows:

- Describe the present status of nutrients concentration with excellent comparability using certified reference material of nutrient in seawater.

(3) Parameters

The determinants are nitrate, nitrite, silicate, phosphate and ammonia in the Arctic Ocean.

(4) Instruments and methods

(4.1) Analytical detail using QuAAtro 2-HR systems (BL-Tech)

Nitrate + nitrite and nitrite are analyzed according to the modification method of Grasshoff (1970). The sample nitrate is reduced to nitrite in a cadmium tube inside of which is coated with metallic copper. The sample stream with its equivalent nitrite is treated with an acidic, sulfanilamide reagent and the nitrite forms nitrous acid which reacts with the sulfanilamide to produce a diazonium ion. N-1-Naphthylethylene-diamine added to the sample stream then couples with the diazonium ion to produce a red, azo dye. With reduction of the nitrate to nitrite, both nitrate and nitrite react and are measured; without reduction, only nitrite reacts. Thus, for the nitrite analysis, no reduction is performed and the alkaline buffer is not necessary. Nitrate is computed by difference.

The silicate method is analogous to that described for phosphate. The method used is essentially that of Grasshoff et al. (1983), wherein silicomolybdic acid is first formed from the silicate in the sample and added molybdic acid; then the silicomolybdic acid is reduced to silicomolybdous acid, or "molybdenum blue," using ascorbic acid as the reductant. The analytical methods of the nutrients, nitrate, nitrite, silicate and phosphate, during this cruise are same as the methods used in (Kawano et al. 2009).

The phosphate analysis is a modification of the procedure of Murphy and Riley (1962). Molybdic acid is added to the seawater sample to form phosphomolybdic acid

which is in turn reduced to phosphomolybdous acid using L-ascorbic acid as the reductant.

The ammonia in seawater is mixed with an alkaline containing EDTA, ammonia as gas state is formed from seawater. The ammonia (gas) is absorbed in sulfuric acid by way of 0.5 μm pore size membrane filter (ADVANTEC PTFE) at the dialyzer attached to analytical system. The ammonia absorbed in sulfuric acid is determined by coupling with phenol and hypochlorite to form indophenols blue. Wavelength using ammonia analysis is 630 nm, which is absorbance of indophenols blue.

The flow diagrams and reagents for each parameter are shown in Figures 4.2-1 to 4.2-5.

Sample inlet line for Nitrate + Nitrite analysis was changed from BLK/BLK ($151 \mu\text{L min.}^{-1}$) to ORN/WHT ($111 \mu\text{L min.}^{-1}$). The effect of reducing of sample volume was longer plateau of peak shapes.

(4.2) Nitrate + Nitrite Reagents

Imidazole (buffer), 0.06 M (0.4 % w/v)

Dissolve 4 g imidazole, $\text{C}_3\text{H}_4\text{N}_2$, in ca. 1000 ml DIW; add 2 ml concentrated HCl After mixing, 1 ml Triton®X-100 (50 % solution in ethanol) is added.

Sulfanilamide, 0.06 M (1 % w/v) in 1.2M HCl

Dissolve 10 g sulfanilamide, $4\text{-NH}_2\text{C}_6\text{H}_4\text{SO}_3\text{H}$, in 900 ml of DIW, add 100 ml concentrated HCl. After mixing, 2 ml Triton®X-100 (50 % solution in ethanol) is added.

N-1-Naphthylethylene-diamine dihydrochloride, 0.004 M (0.1 %f w/v)

Dissolve 1 g NED, $\text{C}_{10}\text{H}_7\text{NHCH}_2\text{CH}_2\text{NH}_2 \cdot 2\text{HCl}$, in 1000 ml of DIW and add 10 ml concentrated HCl. After mixing, 1 ml Triton®X-100 (50 % solution in ethanol) is added. This reagent is stored in a dark bottle.

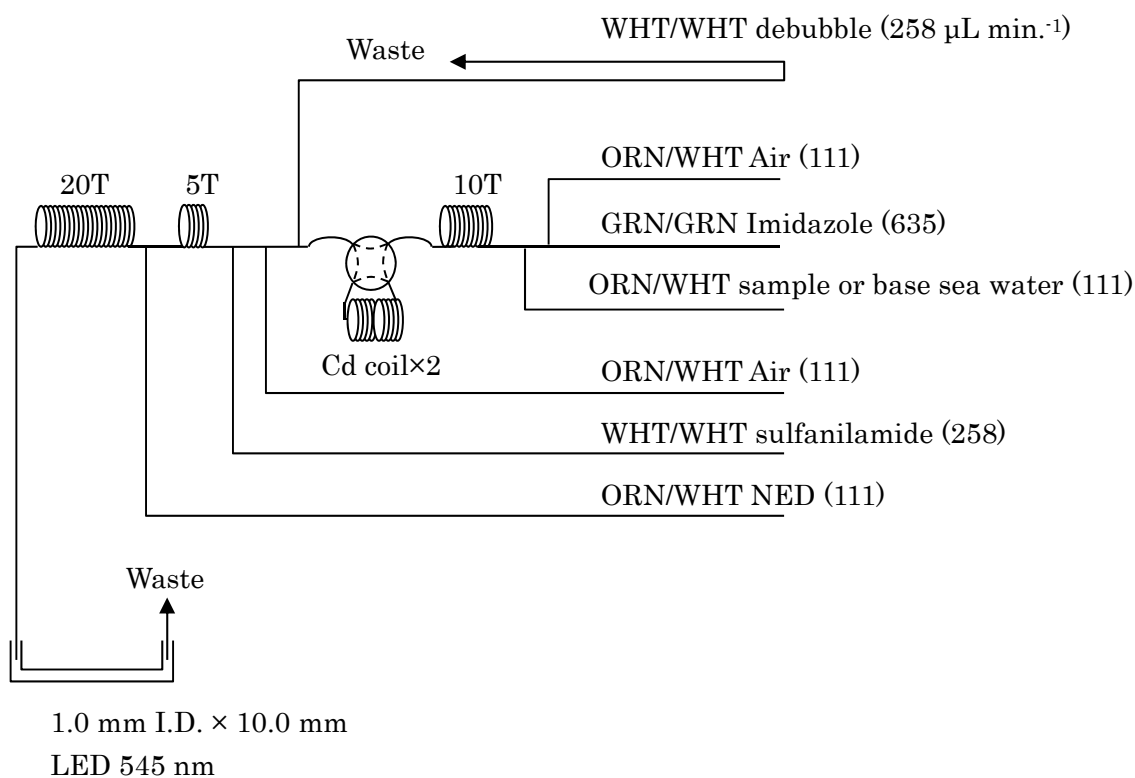

Figure 4.2-1 NO_3+NO_2 (1ch.) Flow diagram.

(4.3) Nitrite Reagents

Sulfanilamide, 0.06 M (1 % w/v) in 1.2 M HCl

Dissolve 10g sulfanilamide, $4\text{-NH}_2\text{C}_6\text{H}_4\text{SO}_3\text{H}$, in 900 ml of DIW, add 100 ml concentrated HCl. After mixing, 2 ml Triton®X-100 (50 % solution in ethanol) is added.

N-1-Naphthylethylene-diamine dihydrochloride, 0.004 M (0.1 % w/v)

Dissolve 1 g NED, $\text{C}_{10}\text{H}_7\text{NHCH}_2\text{CH}_2\text{NH}_2 \cdot 2\text{HCl}$, in 1000 ml of DIW and add 10 ml concentrated HCl. After mixing, 1 ml Triton®X-100 (50 % solution in ethanol) is added. This reagent is stored in a dark bottle.

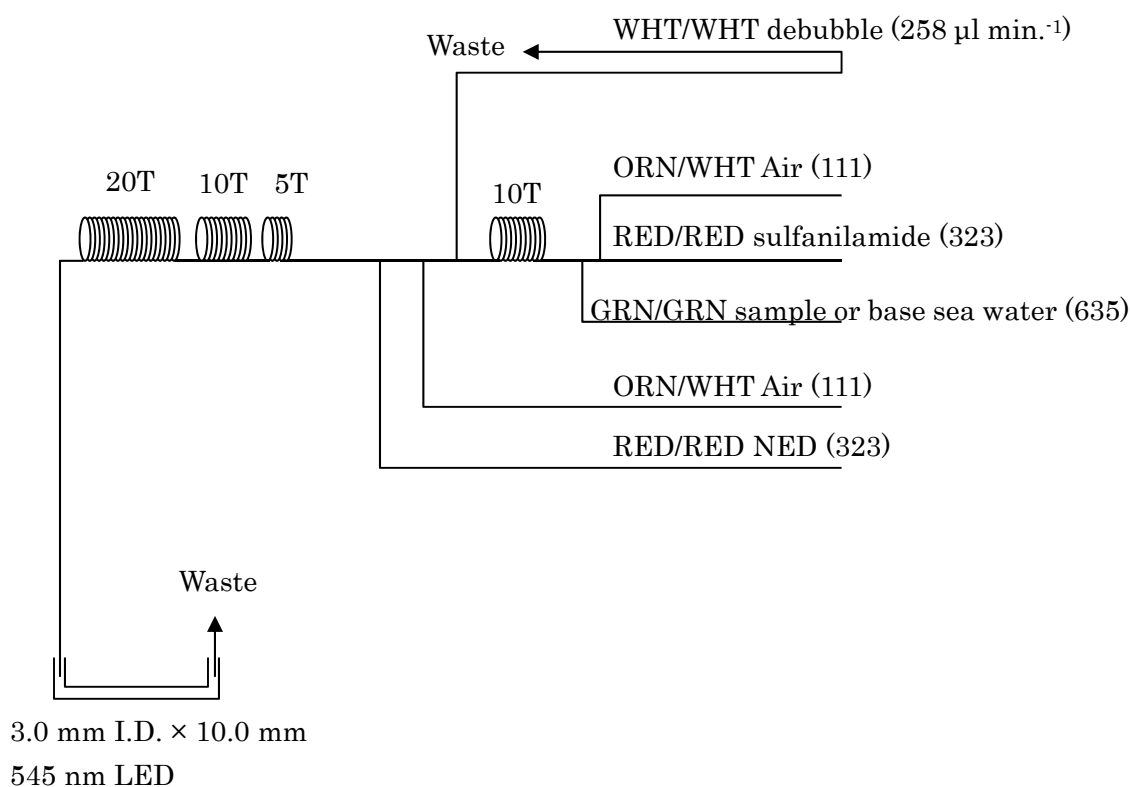

Figure 4.2-2 NO₂ (2ch.) Flow diagram.

(4.4) Silicate Reagents

Molybdic acid, 0.06 M (2 % w/v)

Dissolve 15 g disodium molybdate(VI) dihydrate, Na₂MoO₄·2H₂O, in 980 ml DIW, add 8 ml concentrated H₂SO₄. After mixing, 20 ml sodium dodecyl sulphate (15 % solution in water) is added.

Oxalic acid, 0.6 M (5 % w/v)

Dissolve 50 g oxalic acid anhydrous, HOOC: COOH, in 950 ml of DIW.

Ascorbic acid, 0.01M (3 % w/v)

Dissolve 2.5g L (+)-ascorbic acid, C₆H₈O₆, in 100 ml of DIW. Stored in a dark bottle and freshly prepared before every measurement.

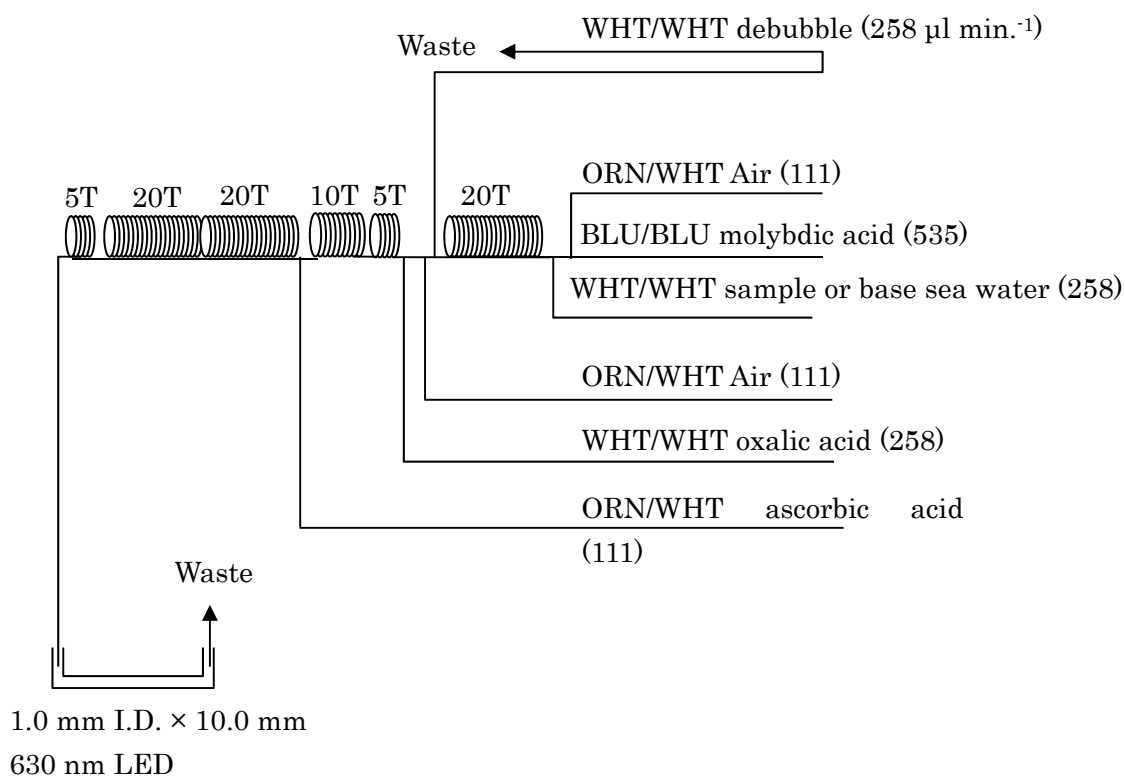

Figure 4.2-3 SiO₂ (3ch.) Flow diagram.

(4.5) Phosphate Reagents

Stock molybdate solution, 0.03M (0.8 % w/v)

Dissolve 8 g disodium molybdate(VI) dihydrate, Na₂MoO₄·2H₂O, and 0.17 g antimony potassium tartrate, C₈H₄K₂O₁₂Sb₂·3H₂O, in 950 ml of DIW and add 50 ml concentrated H₂SO₄.

Mixed Reagent

Dissolve 1.2 g L (+)-ascorbic acid, C₆H₈O₆, in 150 ml of stock molybdate solution. After mixing, 3 ml sodium dodecyl sulphate (15 % solution in water) is added. Stored in a dark bottle and freshly prepared before every measurement.

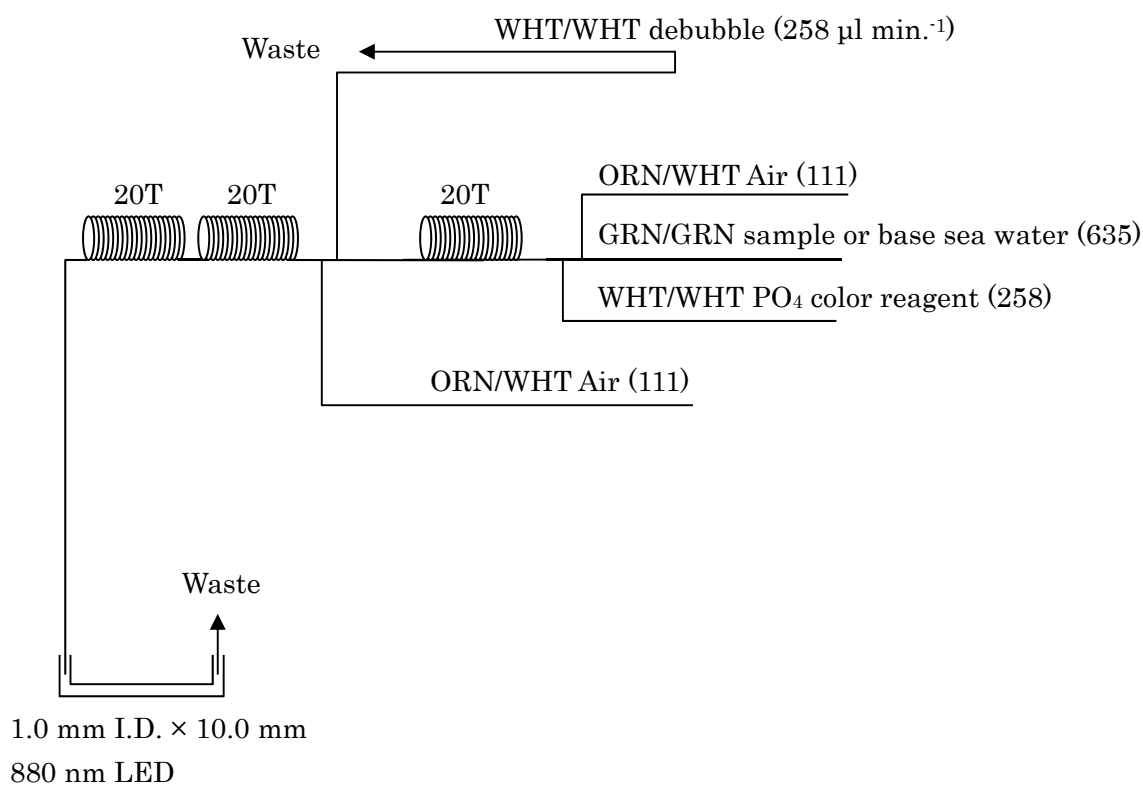

Figure 4.2-4 PO₄ (4ch.) Flow diagram.

(4.6) Ammonia Reagents

EDTA

Dissolve 41 g EDTA (ethylenediaminetetraacetic acid tetrasodium salt), C₁₀H₁₂N₂O₈Na₄•4H₂O, and 2 g boric acid, H₃BO₃, in 200 ml of DIW. After mixing, 1 ml Triton®X-100 (30 % solution in DIW) is added. This reagent is prepared at a week about.

NaOH

Dissolve 5 g sodium hydroxide, NaOH, and 16 g EDTA in 100 ml of DIW. This reagent is prepared at a week about.

Stock Nitroprusside

Dissolved 0.25 g sodium pentacyanonitrosylferrate(II), Na₂[Fe(CN)₅NO], in 100 ml of DIW and add 0.2 ml 1N H₂SO₄. Stored in a dark bottle and prepared at a month about.

Nitroprusside solution

Mixed 4 ml stock nitroprusside and 5 ml 1N H₂SO₄ in 500 ml of DIW. After mixing, 2ml Triton®X-100 (30 % solution in DIW) is added. This reagent is stored in a dark bottle and prepared at every 2 or 3 days.

Alkaline phenol

Dissolved 10 g phenol, C_6H_5OH , 5 g sodium hydroxide and citric acid, $C_6H_8O_7$, in 200 ml DIW. Stored in a dark bottle and prepared at a week about.

NaClO solution

Mixed 3 to 4 ml sodium hypochlorite solution, NaClO, in 46 to 47 ml DIW. Stored in a dark bottle and freshly prepared before every measurement. This reagent is prepared 0.3% available chlorine.

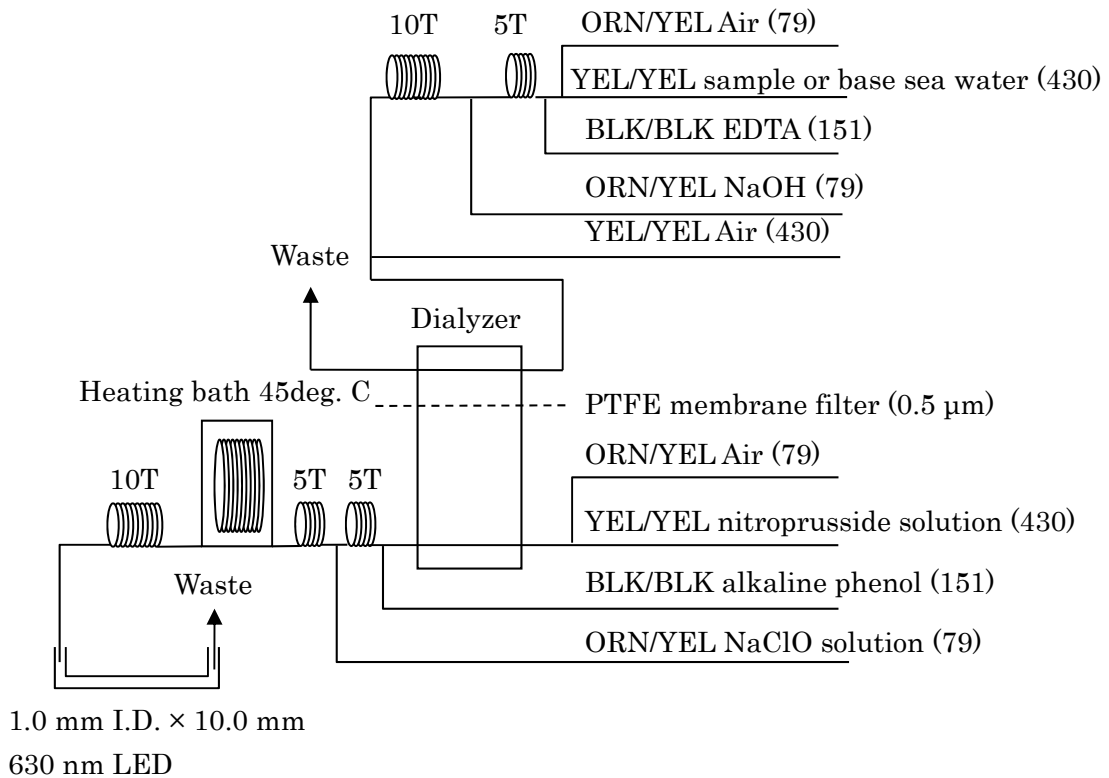

Figure 4.2-5 NH_4 (5ch.) Flow diagram.

(4.7) Sampling procedures

Sampling of nutrients followed that oxygen, salinity and trace gases. Samples were drawn into a virgin 10 ml polyacrylates vials without sample drawing tubes. These were rinsed three times before filling and vials were capped immediately after the drawing. The vials are put into water bath adjusted to ambient temperature, 23 ± 1.0 deg. C, in about 30 minutes before use to stabilize the temperature of samples.

No transfer was made and the vials were set an auto sampler tray directly. Samples were analyzed after collection basically within 24 hours.

(4.8) Data processing

Raw data from QuAAtro 2-HR were treated as follows:

- Check baseline shift.
- Check the shape of each peak and positions of peak values taken, and then change the positions of peak values taken if necessary.
- Carry-over correction and baseline drift correction were applied to peak heights of each samples followed by sensitivity correction.
- Baseline correction and sensitivity correction were done basically using liner regression.
- Load pressure and salinity from CTD data due to calculate density of seawater.
- Calibration curves to get nutrients concentration were assumed second order equations.

(4.9) Summary of nutrients analysis

We made 43 QuAAtro runs for the water columns sample at 95 casts during MR15-03. The total amount of layers of the seawater sample reached up to 1337. We made basically duplicate measurement. The station locations for nutrients measurement is shown in Figure 4.2-6.

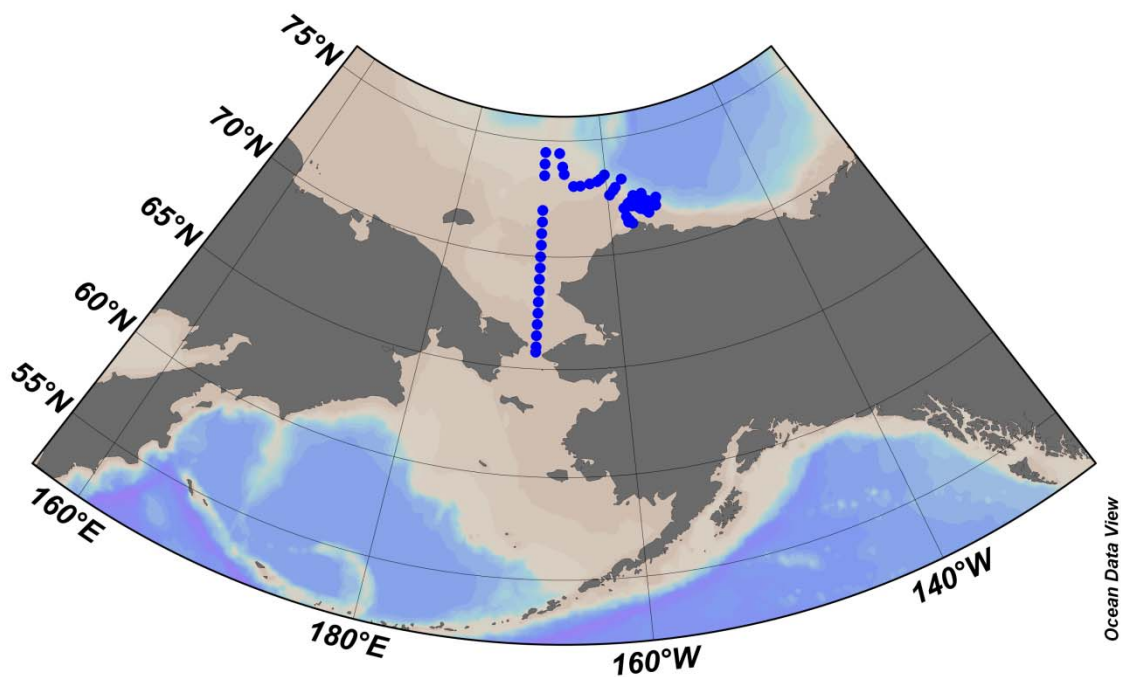

Figure 4.2-6 Sampling positions of nutrients sample.

(5) Station list

The sampling station list for nutrients is shown in Table 4.2-1.

Table 4.2-1 List of stations

Station	Cast	Date (UTC)	Bottom Position		Depth (dbar)
		(mmddyy)	Latitude	Longitude	
001	1	090615	65-45.69N	168-45.19W	51.8
002	1	090615	66-00.02N	168-45.26W	52.8
003	1	090615	66-30.09N	168-45.58W	51.9
004	1	090615	67-00.08N	168-44.99W	44.9
005	1	090615	67-30.02N	168-45.12W	49.5
006	2	090715	67-59.90N	168-46.64W	58.1
007	1	090715	68-30.00N	168-45.10W	53.1
008	1	090715	69-00.04N	168-44.86W	52.5
009	1	090715	69-30.04N	168-44.91W	51.3
010	1	090715	69-59.97N	168-44.98W	40.8
011	1	090715	70-30.09N	168-45.13W	38.6
012	1	090815	70-59.95N	168-45.12W	44.4
013	1	090815	71-20.10N	157-39.87W	98.6
014	1	090915	71-34.73N	157-50.25W	64.6
015	1	090915	71-24.81N	157-30.04W	122.7
016	1	090915	71-14.89N	157-09.66W	46.5
022	1	091115	71-35.99N	154-50.22W	42.0
023	1	091115	71-44.44N	155-12.65W	307.0
023	2	091115	71-46.41N	155-19.83W	186.0
024	1	091115	71-52.67N	156-01.78W	81.1
025	1	091215	71-49.50N	155-50.76W	88.5
026	1	091215	71-48.26N	155-22.71W	149.3
027	1	091215	71-39.95N	155-01.41W	104.0
028	1	091215	72-00.06N	157-28.04W	78.6
029	1	091215	72-07.94N	156-58.04W	131.0
030	1	091215	72-17.37N	156-42.13W	272.0
031	1	091315	72-06.21N	154-40.63W	1096.0
032	1	091315	71-59.99N	154-42.40W	1008.0
032	2	091415	72-00.19N	154-45.65W	786.0
033	1	091415	71-55.03N	154-58.30W	334.0
034	1	091415	71-44.16N	155-12.01W	306.0
035	1	091415	72-01.31N	155-53.57W	148.3
037	1	091415	72-11.04N	155-39.07W	367.0

039	1	091415	72-23.48N	155-24.15W	1448.0
039	2	091415	72-23.54N	155-28.00W	1350.0
040	1	091515	72-26.18N	156-35.45W	870.0
045	1	091515	72-12.49N	156-50.64W	188.0
046	1	091515	72-03.91N	157-13.19W	88.0
047	1	091515	71-57.09N	158-00.06W	65.8
048	1	091515	72-08.32N	157-23.33W	76.2
049	1	091515	72-00.06N	156-53.65W	95.2
050	1	091615	72-05.08N	156-25.93W	149.0
051	1	091615	72-11.44N	156-12.79W	253.9
052	1	091615	72-20.20N	156-10.51W	1076.0
053	4	091615	72-20.42N	155-23.49W	1619.0
053	8	091715	72-20.37N	155-23.10W	1617.0
053	12	091715	72-21.32N	155-23.56W	1682.0
053	16	091815	72-20.50N	155-23.50W	1626.0
054	1	091815	72-28.36N	155-24.08W	2004.0
054	2	091815	72-28.25N	155-23.47W	1998.0
055	1	091915	72-22.93N	155-59.76W	1375.0
056	4	092015	72-16.29N	155-57.29W	444.0
056	8	092015	72-17.55N	156-01.64W	917.0
056	10	092115	72-16.94N	155-59.36W	789.0
056	12	092115	72-16.77N	155-58.53W	679.0
056	16	092115	72-16.90N	155-59.09W	761.0
060	1	092215	72-11.15N	153-33.50W	2110.0
061	1	092215	72-01.29N	153-50.65W	1537.0
062	1	092215	71-49.93N	153-49.47W	176.0
062	2	092215	71-49.93N	153-48.98W	173.0
063	1	092315	72-22.25N	155-31.12W	1302.0
064	1	092315	72-15.87N	155-57.94W	424.0
065	1	092315	72-11.67N	156-15.49W	258.0
066	1	092315	72-15.98N	156-24.88W	398.0
067	1	092315	72-10.05N	155-30.91W	380.0
068	1	092415	72-10.47N	156-13.45W	242.0
069	1	092415	72-10.07N	155-52.48W	274.0
070	1	092415	72-10.05N	156-40.72W	188.0
071	1	092415	72-10.07N	157-11.24W	113.0
072	1	092415	72-34.87N	159-41.40W	54.9
074	1	092415	72-46.81N	159-06.01W	183.0
075	1	092415	73-12.53N	157-48.22W	2595.0

077	1	092515	72-53.23N	158-48.04W	362.0
081	1	092515	73-12.82N	161-15.81W	371.0
082	1	092515	73-08.15N	162-17.91W	201.0
083	1	092615	73-03.57N	163-38.23W	106.0
084	1	092615	73-03.47N	164-36.11W	75.0
085	1	092615	73-18.30N	160-46.74W	428.0
085	2	092615	73-18.61N	160-45.60W	437.0
094	1	092715	73-28.52N	160-08.16W	1615.0
095	1	092815	73-34.07N	165-56.20W	103.0
096	1	092815	73-53.19N	166-09.95W	153.0
098	1	092815	74-27.70N	166-38.13W	314.0
098	2	092815	74-27.76N	166-37.02W	316.0
099	1	092915	74-30.02N	168-45.11W	194.0
100	1	092915	74-00.00N	168-45.29W	181.0
101	1	092915	73-29.92N	168-45.37W	120.0
102	1	092915	72-00.10N	168-44.74W	51.0
103	1	093015	71-30.00N	168-44.98W	48.7
104	1	093015	70-59.92N	168-44.80W	45.0
105	1	093015	70-29.96N	168-45.13W	38.0
106	1	100115	67-59.90N	168-44.82W	58.0
107	1	100115	68-29.93N	168-45.01W	54.0
108	1	100315	67-00.02N	168-44.89W	45.0
109	1	100315	66-00.12N	168-45.04W	52.5

(6) Nutrients standards

(6.1) Volumetric laboratory ware of in-house standards

All volumetric glass ware and polymethylpentene (PMP) ware used were gravimetrically calibrated. Plastic volumetric flasks were gravimetrically calibrated at the temperature of use within 0 to 4 K.

(6.1.1) Volumetric flasks

Volumetric flasks of Class quality (Class A) are used because their nominal tolerances are 0.05 % or less over the size ranges likely to be used in this work. Class A flasks are made of borosilicate glass, and the standard solutions were transferred to plastic bottles as quickly as possible after they are made up to volume and well mixed in order to prevent excessive dissolution of silicate from the glass. PMP volumetric flasks were gravimetrically calibrated and used only within 0 to 4 K of the calibration temperature.

The computation of volume contained by glass flasks at various temperatures other than the calibration temperatures were done by using the coefficient of linear expansion of borosilicate crown glass.

Because of their larger temperature coefficients of cubical expansion and lack of tables constructed for these materials, the plastic volumetric flasks were gravimetrically calibrated over the temperature range of intended use and used at the temperature of calibration within 0 to 4 K. The weights obtained in the calibration weightings were corrected for the density of water and air buoyancy.

(6.1.2) Pipettes and pipettors

All pipettes have nominal calibration tolerances of 0.1 % or better. These were gravimetrically calibrated in order to verify and improve upon this nominal tolerance.

(6.2) Reagents, general considerations

(6.2.1) Specifications

For nitrate standard, “potassium nitrate 99.995 suprapur®” provided by Merck, Lot. B0771365211, CAS No.: 7757-91-1, was used.

For nitrite standard solution, we used “nitrous acid iron standard solution (NO₂⁻ 1000) provided by Wako, Lot ECP4122, Code. No. 140-06451.” This standard solution was certified by Wako using Ion chromatograph method. Calibration result is 999 mg/L at 20 deg. C. Expanded uncertainty of calibration (k=2) is 0.7 % for the calibration result.

For phosphate standard, “potassium dihydrogen phosphate anhydrous 100.000 suprapur®” provided by Merck, Lot. B0691108204, CAS No.: 7778-77-0, was used.

For the silicate standard, we use “Silicon standard solution SiO₂ in NaOH 0.5 mol/l CertiPUR®” provided by Merck, CAS No.: 1310-73-2, of which lot number is HC382250 are used. The silicate concentration is certified by NIST-SRM3150 with the uncertainty

of 0.5 %. HC382250 is certified as 1001 mg L⁻¹.

For ammonia standard, “ammonium Chloride” provided by NMIJ. We used NMIJ CRM 3011-a. The purity of this standard was greater than 99.9%. Expanded uncertainty of calibration (k=2) is 0.065%.

(6.2.2) Ultra-pure water

Ultra-pure water (Milli-Q water) freshly drawn was used for preparation of reagent, standard solutions and for measurement of reagent and system blanks.

(6.2.3) Low nutrients seawater (LNSW)

Surface water having low nutrient concentration was taken and filtered using 0.20 µm pore size membrane filter at MR14-06 cruise on November, 2014. This water is stored in 20 liter cubitainer with paper box.

We put 800 liter LNSW into gather the 1000 liter plastic bag (SHOWA PAXXS), which was sterilized for gamma irradiation with 15 kGy. Filtering with 0.20 µm/0.45 µm pore size cartridge filter (Surtobran P 0.2 µm), we’ve sterilized UV ray to LNSW for 36 hours used by “UV sterilization system”. After that, LNSW was stored in 20 liter cubitainer with paper box again. LNSW concentrations were assigned to August, 2015 on MR15-03 cruise.

(6.2.4) Concentrations of nutrients for A, D, B and C standards

Concentrations of nutrients for A, D, B and C standards are set as shown in Table 4.2-2. The C standard is prepared according recipes as shown in Table 4.2-3. All volumetric laboratory tools were calibrated prior the cruise as stated in chapter (6.1) Then the actual concentration of nutrients in each fresh standard was calculated based on the ambient, solution temperature and determined factors of volumetric laboratory wares.

The calibration curves for each run were obtained using 4 levels, C-1, C-2, C-3 and C-4. We used 4 levels calibration curve.

Table 4.2-2 Nominal concentrations of nutrients for A, D, B and C standards.

	A	D	B	C-1	C-2	C-3	C-4
NO ₃ (µM)	22550	900	680	0	14	27	41
NO ₂ (µM)	21720	870	26	0	0.5	1.0	1.5
SiO ₂ (µM)	35000		1400	0	28	56	84
PO ₄ (µM)	3000		60	0	1.2	2.4	3.6
NH ₄ (µM)	4000		320	0	3.2	6.4	9.6

Table 4.2-3 Working calibration standard recipes.

C Std.	B-1 Std.	B-2 Std.	B-3 Std.	DIW
C-1	0 ml	0 ml	0 ml	75 ml
C-2	10 ml	10 ml	5 ml	50 ml
C-3	20 ml	20 ml	10 ml	25 ml
C-4	30 ml	30 ml	15 ml	0 ml

B-1 Std.: Mixture of nitrate, silicate and phosphate
B-2 Std.: Nitrite
B-3 Std.: Ammonia

(6.2.5) Renewal of in-house standard solutions

In-house standard solutions as stated in paragraph (6.2) were renewed as shown in Table 4.2-4(a) to (c).

Table 4.2-4(a) Timing of renewal of in-house standards.

NO ₃ , NO ₂ , SiO ₂ , PO ₄ , NH ₄	Renewal
A-1 Std. (NO ₃)	maximum a month
A-2 Std. (NO ₂)	commercial prepared solution
A-3 Std. (SiO ₂)	commercial prepared solution
A-4 Std. (PO ₄)	maximum a month
A-5 Std. (NH ₄)	maximum a month
D-1 Std.	maximum 8 days
D-2 Std.	maximum 8 days
B-1 Std. (mixture of A-1, A-3 and A-4 std.)	maximum 8 days
B-2 Std. (dilute D-2 std.)	maximum 8 days
B-3 Std. (dilute A-5 std.)	maximum 8 days

Table 4.2-4(b) Timing of renewal of working calibration standards.

Working standards	Renewal
C Std. (mixture of B-1, B-2 and B-3 Std.)	every 24 hours

Table 4.2-4(c) Timing of renewal of in-house standards for reduction estimation.

Reduction estimation	Renewal
36 µM NO ₃	when C Std. renewed
35 µM NO ₂	when C Std. renewed

(7) Certified Reference Material of nutrients in seawater

To get the more accurate and high quality nutrients data to achieve the objectives stated above, huge numbers of the bottles of the Certified Reference Material of nutrients in seawater (hereafter CRM), which were recently certified by JAMSTEC and KANSO, are prepared (Aoyama et al., 2006, 2007, 2008, 2009, Certifications BY, BU, CA, BW). In the previous worldwide expeditions, such as WOCE cruises, the higher reproducibility and precision of nutrients measurements were required (Joyce and Corry, 1994). Since no standards were available for the measurement of nutrients in seawater at that time, the requirements were described in term of reproducibility. The required reproducibility was 1 %, 1 to 2 %, 1 to 3 % for nitrate, phosphate and silicate, respectively. Although nutrient data from the WOCE one-time survey was of unprecedented quality and coverage due to much care in sampling and measurements, the differences of nutrients concentration at crossover points are still found among the expeditions (Aoyama and Joyce, 1996, Mordy et al., 2000, Gouretski and Jancke, 2001). For instance, the mean offset of nitrate concentration at deep waters was $0.5 \mu\text{mol kg}^{-1}$ for 345 crossovers at world oceans, though the maximum was $1.7 \mu\text{mol kg}^{-1}$ (Gouretski and Jancke, 2001). At the 31 crossover points in the Pacific WHP one-time lines, the WOCE standard of reproducibility for nitrate of 1 % was fulfilled at about half of the crossover points and the maximum difference was 7 % at deeper layers below 1.6 deg. C in potential temperature (Aoyama and Joyce, 1996).

(7.1) CRM for this cruise

CRM lots BY, BU, CA and BW, which cover full range of nutrients concentrations in the Arctic Ocean are prepared 55 sets.

These CRM assignment were completely done based on random number. The CRM bottles were stored at a room in the ship, REAGENT STORE, where the temperature was maintained around 16.5 - 23.0 deg. C.

(7.2) CRM concentration

We used nutrients concentrations for CRM lots BY, BU, CA and BW as shown in Table 4.2-5.

Table 4.2-5 Certified concentration of CRMs.

Lot	unit: $\mu\text{mol kg}^{-1}$				
	Nitrate	Nitrite	Phosphate	Silicate	Ammonia*
BY	0.02	0.02	0.039	1.76	0.90
BU	3.94	0.07	0.345	20.92	0.99
CA	19.66	0.06	1.407	36.58	0.67
BW	24.59	0.07	1.541	60.01	0.93

*For ammonia values are references

(8) Quality control

(8.1) Precision of nutrients analyses during the cruise

Precision of nutrients analyses during this cruise was evaluated based on the 5 to 9 measurements, which are measured every 7 to 14 samples, during a run at the concentration of C-4 std. Summary of precisions are shown as shown in Table 4.2-6 and Figures 4.2-7 to 4.2-11, Analytical precisions previously evaluated were 0.08 % for nitrate, 0.10 % for phosphate and 0.07 % for silicate in CLIVAR P21 revisited cruise of MR09-01 cruise in 2009, respectively. During in this cruise, analytical precisions were 0.10% for nitrate, 0.16% for nitrite, 0.11% for silicate, 0.12% for phosphate and 0.34% for ammonia in terms of median of precision, respectively. Then we can conclude that the analytical precisions for nitrate, nitrite, silicate, phosphate and ammonia were maintained throughout this cruise.

Table 4.2-6 Summary of precision based on the replicate analyses.

	Nitrate	Nitrite	Silicate	Phosphate	Ammonia
	CV %	CV %	CV %	CV %	CV%
Median	0.11	0.16	0.12	0.12	0.35
Mean	0.11	0.16	0.12	0.12	0.39
Maximum	0.24	0.41	0.32	0.21	0.96
Minimum	0.04	0.05	0.03	0.05	0.16
N	43	43	43	43	43

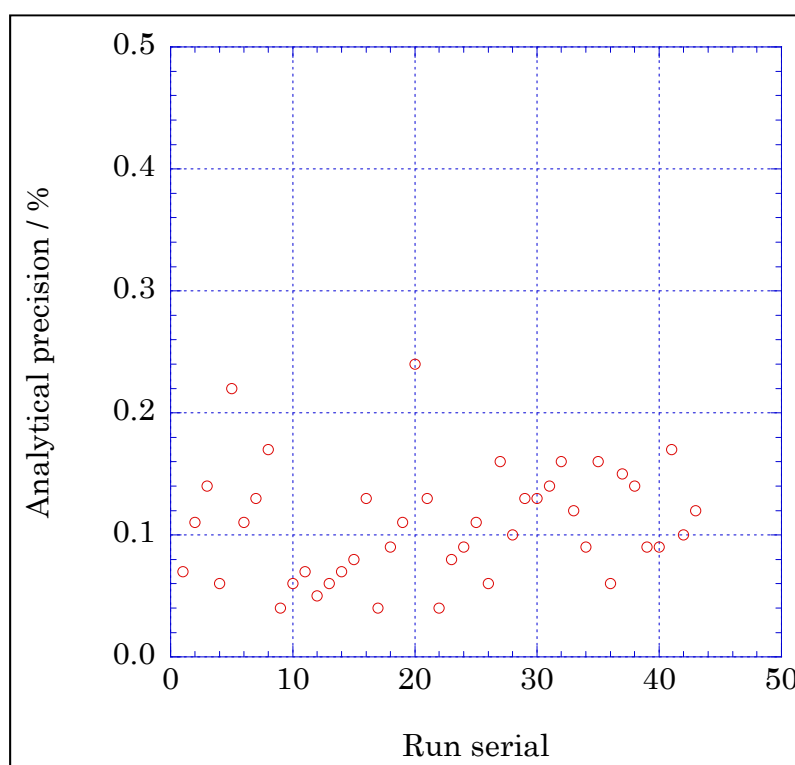

Figure 4.2-7 Time series of precision of nitrate in MR15-03.

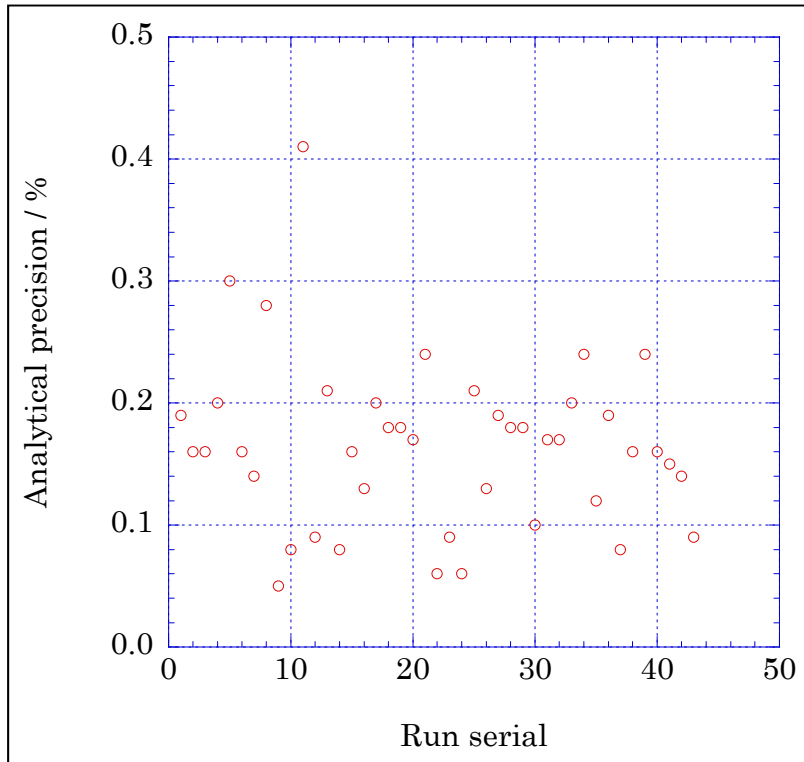

Figure 4.2-8 Time series of precision of nitrite in MR15-03.

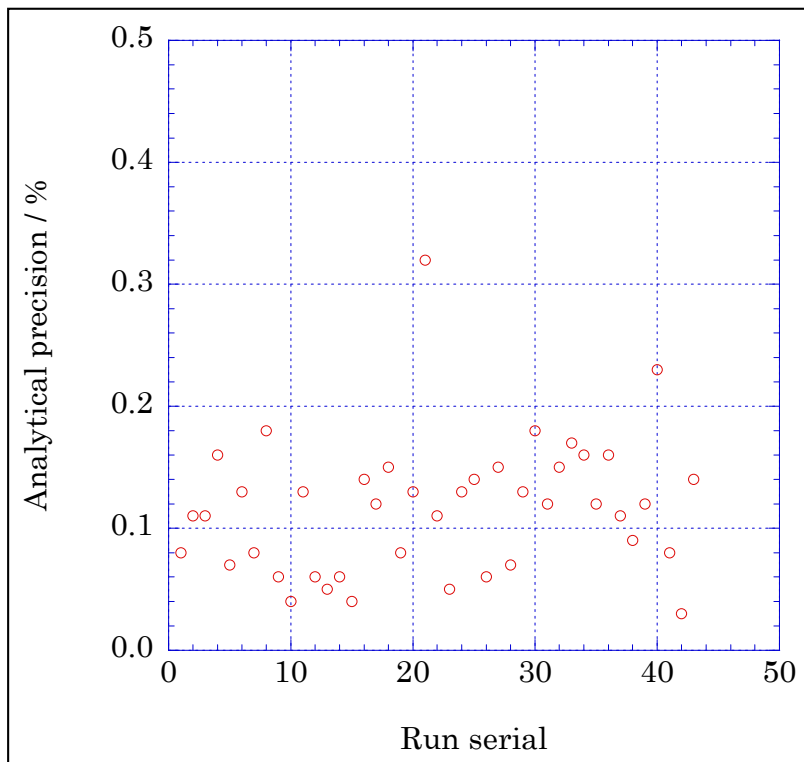

Figure 4.2-9 Time series of precision of silicate in MR15-03.

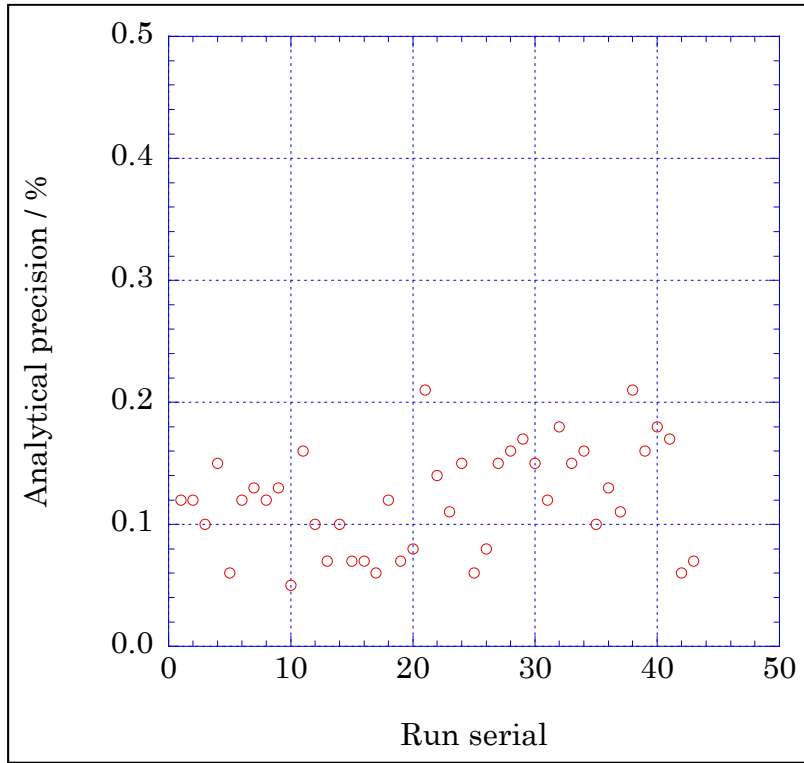

Figure 4.2-10 Time series of precision of phosphate in MR15-03.

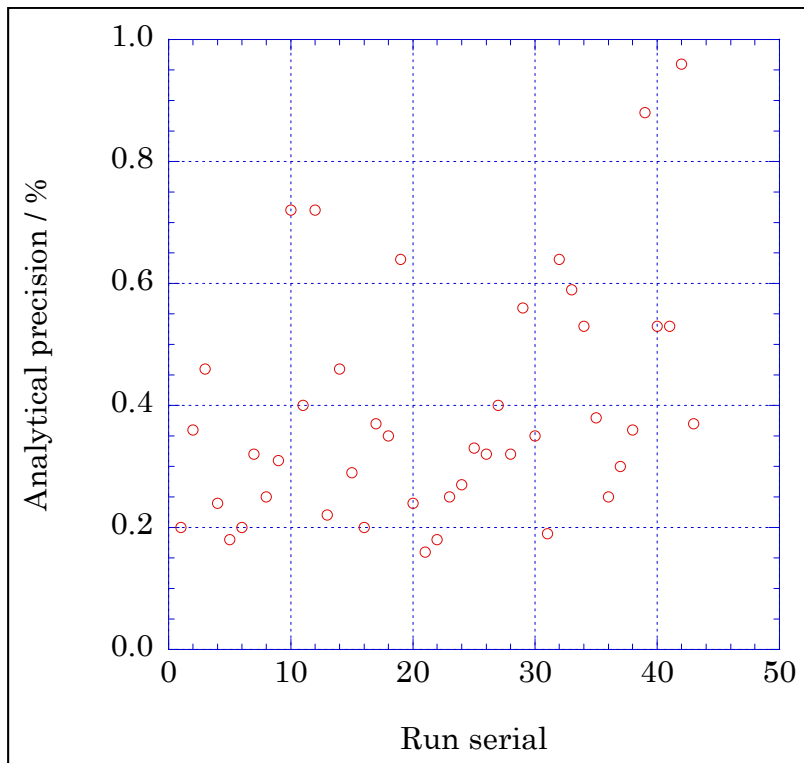

Figure 4.2-11 Time series of precision of ammonia in MR15-03.

(8.2) CRM lot. BW measurement during this cruise

CRM lot. BW was measured every run to keep the comparability. The results of lot. BW during this cruise are shown as Figures 4.2-12 to 4.2-16.

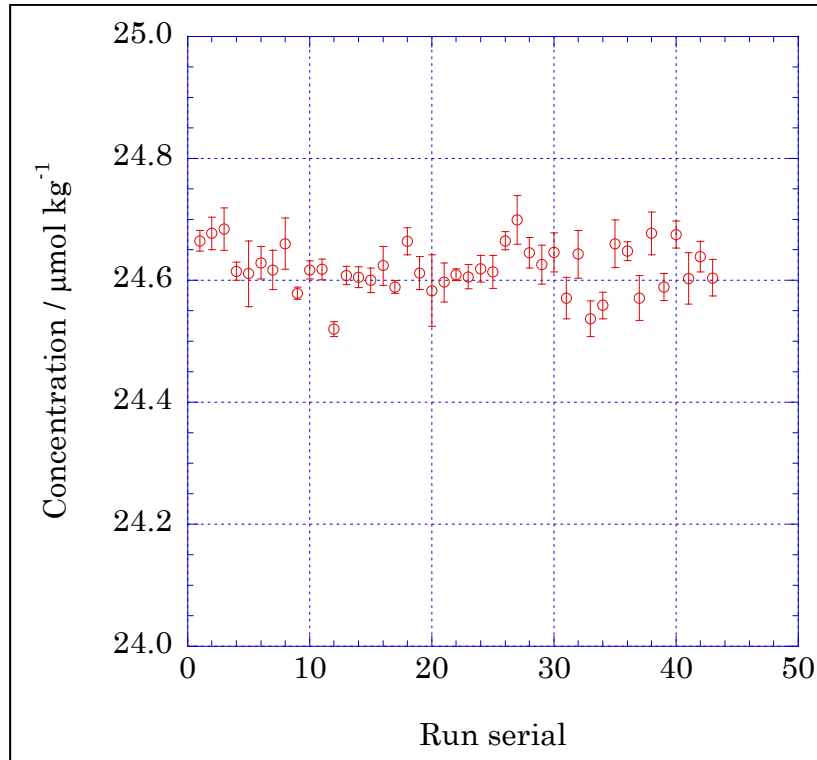

Figure 4.2-12 Time series of CRM-BW of nitrate in MR15-03.

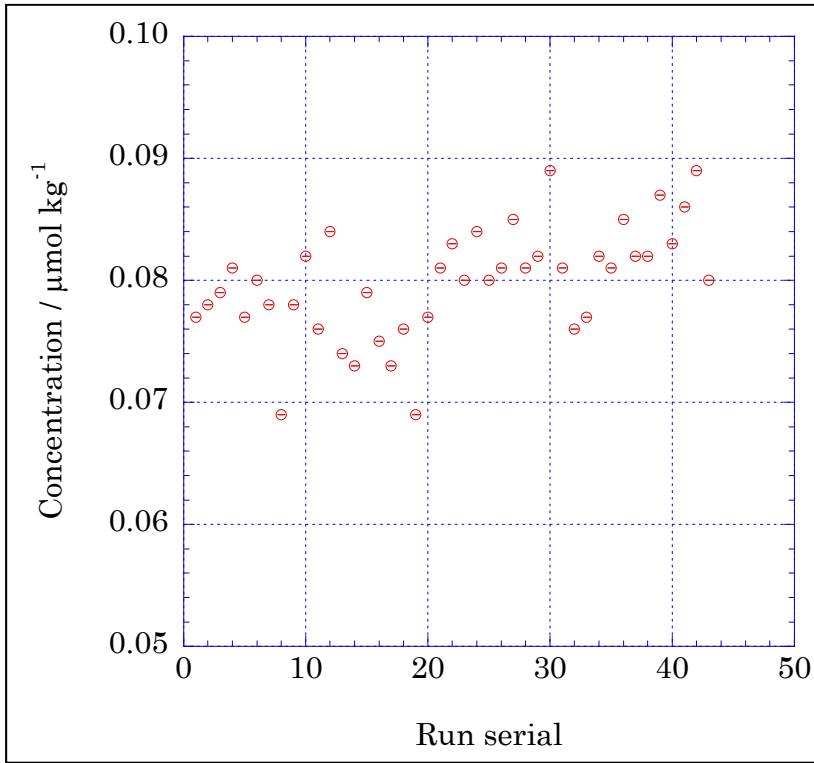

Figure 4.2-13 Time series of CRM-BW of nitrite in MR15-03.

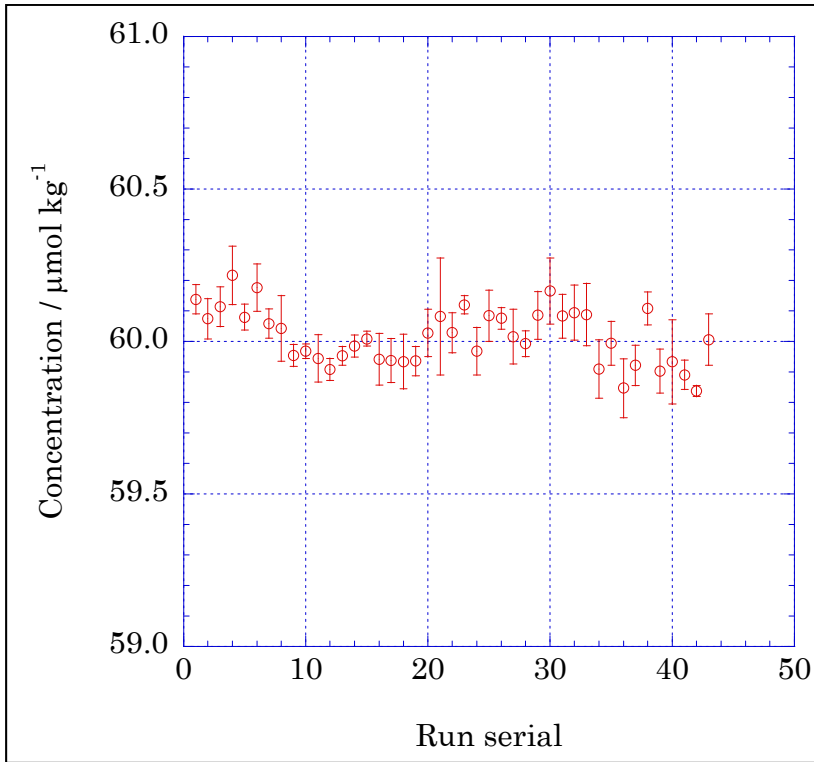

Figure 4.2-14 Time series of CRM-BW of silicate in MR15-03.

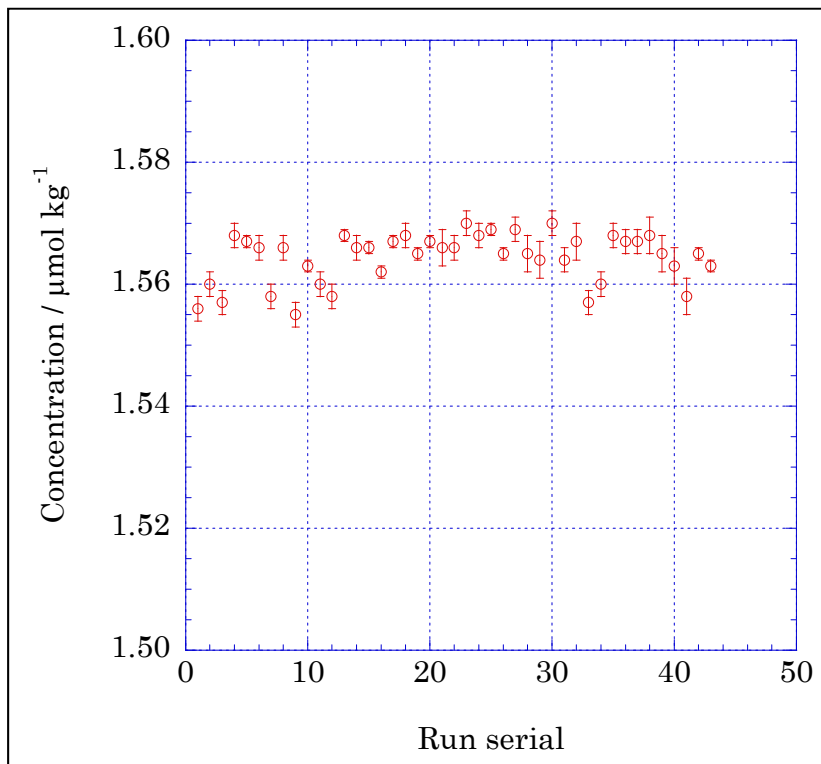

Figure 4.2-15 Time series of CRM-BW of phosphate in MR15-03.

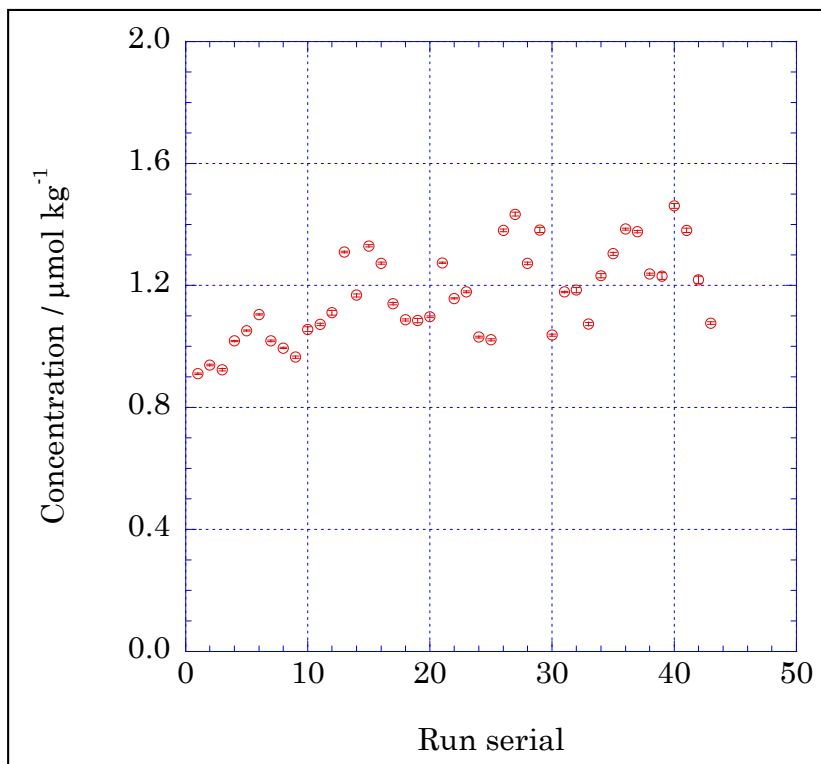

Figure 4.2-16 Time series of CRM-BW of ammonia in MR15-03.

(8.3) Carry over

We can also summarize the magnitudes of carry over throughout the cruise. These are small enough within acceptable levels as shown in Table 4.2-7 and Figure 4.2-17 to 4.2-21.

Table 4.2-7 Summary of carry over throughout MR15-03.

	Nitrate	Nitrite	Silicate	Phosphate	Ammonia
	%	%	%	%	%
Median	0.13	0.05	0.08	0.17	0.75
Mean	0.13	0.08	0.07	0.16	0.74
Maximum	0.19	0.27	0.13	0.27	1.15
Minimum	0.09	0.00	0.02	0.10	0.10
N	43	43	43	43	43

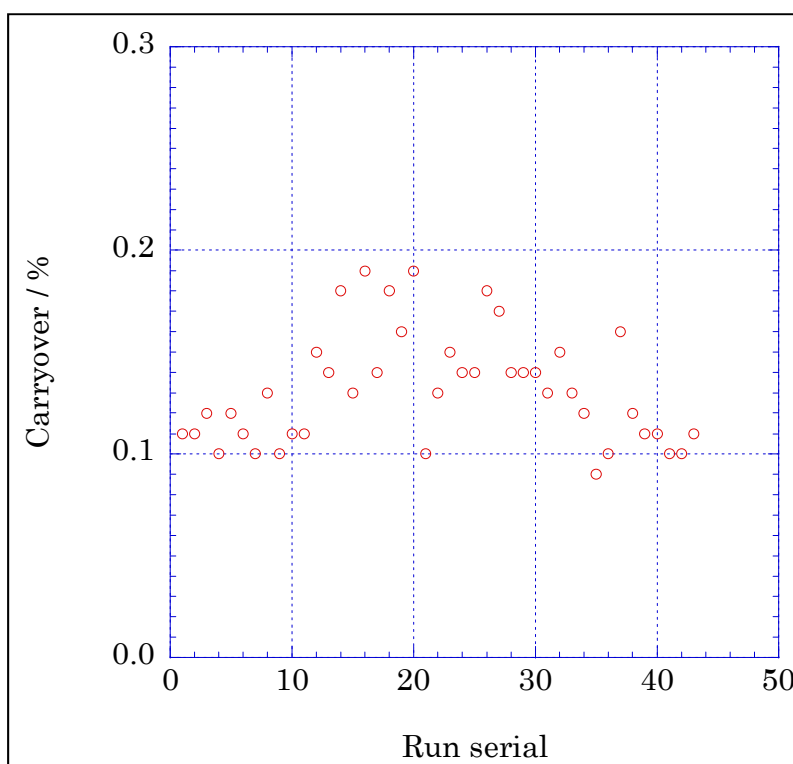

Figure 4.2-17 Time series of carry over of nitrate in MR15-03.

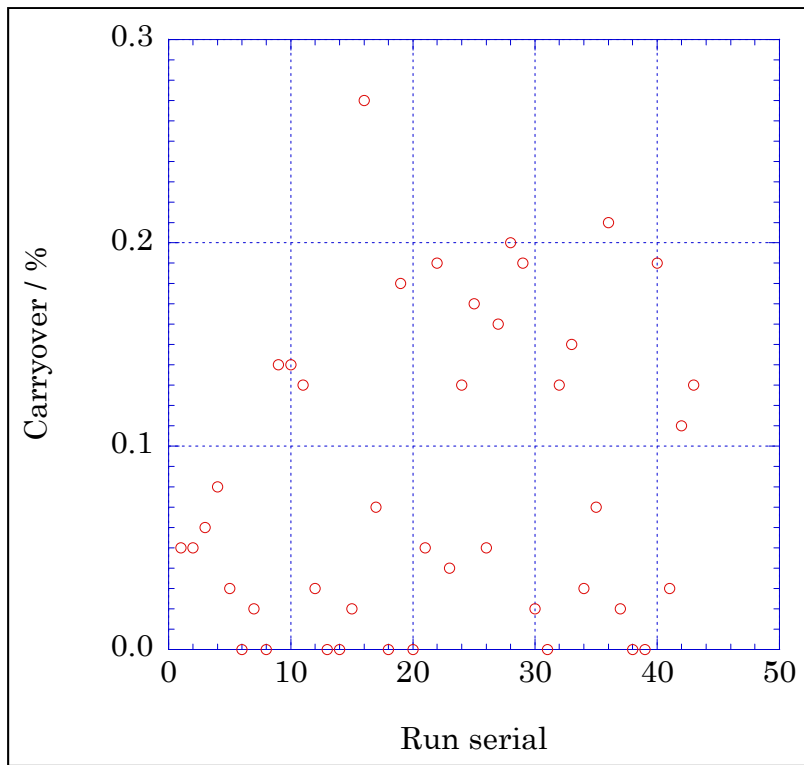

Figure 4.2-18 Time series of carry over of nitrite in MR15-03.

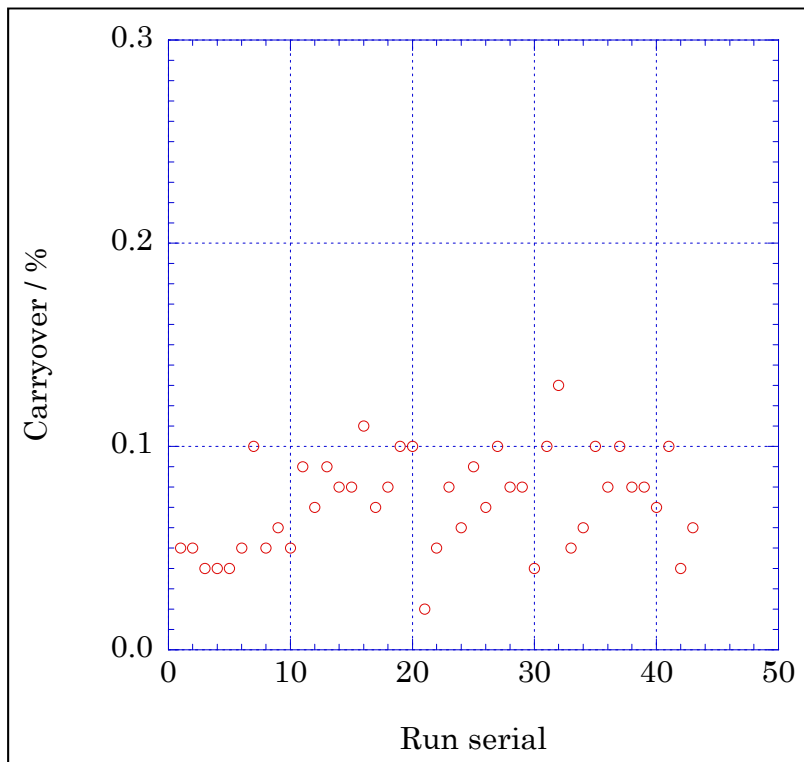

Figure 4.2-19 Time series of carry over of silicate in MR15-03.

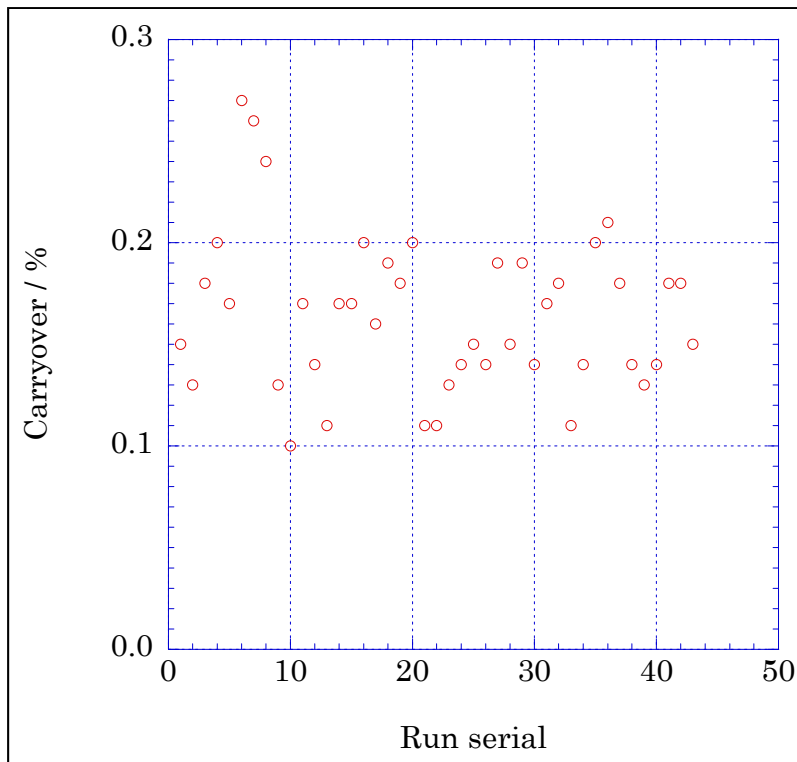

Figure 4.2-20 Time series of carry over of phosphate in MR15-03.

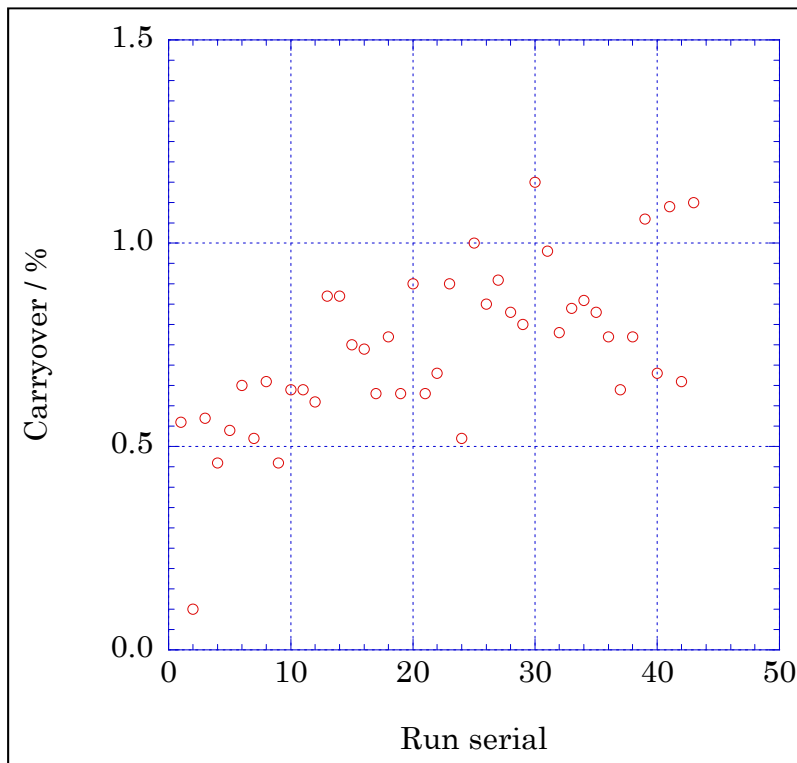

Figure 4.2-21 Time series of carry over of ammonia in MR15-03.

(8.4) Estimation of uncertainty of phosphate, nitrate and silicate concentrations

Empirical equations, eq. (1), (2) and (3) to estimate uncertainty of measurement of nitrate, silicate and phosphate are used based on measurements of 43 sets of CRMs during this cruise. These empirical equations are as follows, respectively.

Nitrate Concentration C_{NO_3} in $\mu\text{mol kg}^{-1}$:

$$\text{Uncertainty of measurement of nitrate (\%)} = 0.11465 + 1.2915 * (1 / C_{NO_3}) \quad \text{--- (1)}$$

where C_{NO_3} is nitrate concentration of sample.

Silicate Concentration C_{Si} in $\mu\text{mol kg}^{-1}$:

$$\text{Uncertainty of measurement of silicate (\%)} = 0.033074 + 8.7115 * (1 / C_{Si}) \quad \text{--- (2)}$$

where C_{Si} is silicate concentration of sample.

Phosphate Concentration C_{PO_4} in $\mu\text{mol kg}^{-1}$:

$$\text{Uncertainty of measurement of phosphate (\%)} = 0.045574 + 0.35303 * (1 / C_{PO_4}) + 0.0035464 * (1 / C_{PO_4}) * (1 / C_{PO_4}) \quad \text{--- (3)}$$

where C_{PO_4} is phosphate concentration of sample.

Empirical equations, eq. (4) and (5) to estimate uncertainty of measurement of nitrite and ammonia are used based on duplicate measurements of the samples.

Nitrite Concentration C_{NO_2} in $\mu\text{mol kg}^{-1}$:

$$\text{Uncertainty of measurement of nitrite (\%)} = -0.14377 + 0.33373 * (1 / C_{NO_2}) - 0.0009666 * (1 / C_{NO_2}) * (1 / C_{NO_2}) \quad \text{--- (4)}$$

where C_{NO_2} is nitrite concentration of sample.

Ammonia Concentration C_{NH_4} in $\mu\text{mol kg}^{-1}$:

$$\text{Uncertainty of measurement of ammonia (\%)} = 0.36001 + 2.2138 / C_{NH_4} \quad \text{--- (5)}$$

where C_{NH_4} is ammonia concentration of sample.

(9) Problems / improvements occurred and solutions.

(9.1) Use 3% H_2O_2 for line cleaning

In this cruise, we used 3% H_2O_2 for line cleaning. H_2O_2 was into for 30 second from sample probe. That was because carry over for Nitrate + Nitrite, Silicate, Phosphate were less than MR14-05 cruise (approximately 0.20%).

(9.2) filtered samples

When we found a lot of particles in the sample, we filtered samples by using $0.45 \mu\text{m}$

pore filter (Millex-HV 33 mm PVDF 0.45 μm). The filtered sample list for nutrients is shown in Table 4.2-8.

Table 4.2-8 List of filtered samples.

Station	Cast	Niskin	Depth (dbar)	Remarks
82	1	1	197.9	filtered only secondary
83	1	1	94.2	filtered only secondary
84	1	1	69.6	filtered only secondary
102	1	Bucket	0	filtered
102	1	23	4.5	filtered
102	1	22	9.9	filtered
102	1	14	12	filtered
102	1	21	20.2	filtered
102	1	10	22.4	filtered
102	1	25	22.9	filtered
102	1	20	29.8	filtered
102	1	7	31.3	filtered
102	1	3	37.1	filtered
102	1	19	39.7	filtered
102	1	8	50.1	filtered
102	1	1	50.4	filtered
103	1	21	19.9	filtered
103	1	20	29.9	filtered
103	1	19	40	filtered
103	1	1	44.3	filtered
104	1	Bucket	0	filtered
104	1	23	5.8	filtered
104	1	22	10.8	filtered
104	1	21	20.4	filtered
104	1	20	30.2	filtered
104	1	25	34.2	filtered
104	1	1	40	filtered
105	1	Bucket	0	filtered
105	1	23	5.5	filtered
105	1	25	8.1	filtered
105	1	22	9.8	filtered
105	1	21	19.7	filtered
105	1	20	29.9	filtered
105	1	1	33.1	filtered

106	1	Bucket	0	filtered
106	1	1	49.3	filtered
107	1	Bucket	0	filtered
107	1	23	5.1	filtered
107	1	22	10.2	filtered
107	1	21	20	filtered
107	1	25	24.9	filtered
107	1	20	30.1	filtered
107	1	19	40.6	filtered
107	1	1	48.5	filtered
108	1	Bucket	0	filtered
108	1	23	5.5	filtered
108	1	22	9.9	filtered
108	1	34	15.3	filtered
108	1	21	20.3	filtered
108	1	31	25.7	filtered
108	1	20	29.8	filtered
108	1	30	32.1	filtered
108	1	25	34.8	filtered
108	1	27	35.2	filtered
108	1	29	40.4	filtered
108	1	1	40.4	filtered

(10) Data archives

These data obtained in this cruise will be submitted to the Data Management Group of JAMSTEC, and will be opened to the public via “Data Research System for Whole Cruise Information in JAMSTEC (DARWIN)” in JAMSTEC web site.

<<http://www.godac.jamstec.go.jp/darwin/e>>

(11) Several works for Leg2

We collected seawater for CRM at the 1000 liter plastic bag (SHOWA PAXXS), which was sterilized for gamma irradiation with 15 kGy. Filtering with 0.20 μm /0.45 μm pore size cartridge filter (Surtobran P 0.2 μm), we’ve sterilized UV ray for 24 hours used by “UV sterilization system”. Detailed information seawater collection and nutrients concentrations before and after UV exposure are shown in Table 4.2-9 to 4.2-11.

Table 4.2-9 Sampling position and layer.

Cast	latitude	longitude	Time (UTC)	Depth (dbar)
1	45-76.70 N	166-47.43 E	10/14/2015 18:54	1200
2	45-77.47 N	166-47.04 E	10/14/2015 21:25	1200

3	45-79.90 N	166-49.42 E	10/14/2015 23:45	1200
---	------------	-------------	------------------	------

Table 4.2-10 Nutrient concentrations before UV exposure.

Cast	Niskin	Nitrate $\mu\text{mol kg}^{-1}$	Nitrite $\mu\text{mol kg}^{-1}$	Silicate $\mu\text{mol kg}^{-1}$	Phosphate $\mu\text{mol kg}^{-1}$	Ammonia $\mu\text{mol kg}^{-1}$
1	1	43.61	0.01	159.56	3.125	0.06
1	10	43.63	0.01	159.48	3.124	0.06
1	19	43.68	0.01	160.11	3.128	0.06
1	28	43.58	0.01	159.78	3.126	0.05
2	4	43.55	0.01	160.01	3.120	0.03
2	13	43.49	0.01	159.87	3.119	0.03
2	22	43.50	0.01	159.99	3.119	0.02
2	31	43.48	0.01	160.00	3.120	0.02
3	7	43.63	0.01	159.95	3.132	0.01
3	16	43.59	0.01	159.46	3.126	0.02
3	25	43.62	0.01	159.92	3.130	0.02
3	34	43.66	0.01	160.19	3.135	0.03

Table 4.2-11 Nutrient concentrations after UV exposure.

Nitrate $\mu\text{mol kg}^{-1}$	Nitrite $\mu\text{mol kg}^{-1}$	Silicate $\mu\text{mol kg}^{-1}$	Phosphate $\mu\text{mol kg}^{-1}$	Ammonia $\mu\text{mol kg}^{-1}$
43.26	0.18	159.48	3.116	0.01
43.26	0.25	159.81	3.119	0.01
43.21	0.27	159.88	3.121	0.02
43.22	0.26	159.88	3.122	0.01
43.20	0.27	159.85	3.122	0.02

(12) References

- Aminot, A. and Kerouel, R. 1991. Autoclaved seawater as a reference material for the determination of nitrate and phosphate in seawater. *Anal. Chim. Acta*, 248: 277-283.
- Aminot, A. and Kirkwood, D.S. 1995. Report on the results of the fifth ICES intercomparison exercise for nutrients in sea water, ICES coop. Res. Rep. Ser., 213.
- Aminot, A. and Kerouel, R. 1995. Reference material for nutrients in seawater: stability of nitrate, nitrite, ammonia and phosphate in autoclaved samples. *Mar. Chem.*, 49: 221-232.
- Aoyama M., and Joyce T.M. 1996, WHP property comparisons from crossing lines in North Pacific. In Abstracts, 1996 WOCE Pacific Workshop, Newport Beach, California.

- Aoyama, M., 2006: 2003 Intercomparison Exercise for Reference Material for Nutrients in Seawater in a Seawater Matrix, Technical Reports of the Meteorological Research Institute No.50, 91pp, Tsukuba, Japan.
- Aoyama, M., Susan B., Minhan, D., Hideshi, D., Louis, I. G., Kasai, H., Roger, K., Nurit, K., Doug, M., Murata, A., Nagai, N., Ogawa, H., Ota, H., Saito, H., Saito, K., Shimizu, T., Takano, H., Tsuda, A., Yokouchi, K., and Agnes, Y. 2007. Recent Comparability of Oceanographic Nutrients Data: Results of a 2003 Intercomparison Exercise Using Reference Materials. *Analytical Sciences*, 23: 1151-1154.
- Aoyama M., J. Barwell-Clarke, S. Becker, M. Blum, Braga E. S., S. C. Coverly, E. Czobik, I. Dahllof, M. H. Dai, G. O. Donnell, C. Engelke, G. C. Gong, Gi-Hoon Hong, D. J. Hydes, M. M. Jin, H. Kasai, R. Kerouel, Y. Kiyomono, M. Knockaert, N. Kress, K. A. Kroglund, M. Kumagai, S. Leterme, Yarong Li, S. Masuda, T. Miyao, T. Moutin, A. Murata, N. Nagai, G. Nausch, M. K. Ngirchchol, A. Nybakk, H. Ogawa, J. van Ooijen, H. Ota, J. M. Pan, C. Payne, O. Pierre-Duplessix, M. Pujo-Pay, T. Raabe, K. Saito, K. Sato, C. Schmidt, M. Schuett, T. M. Shammon, J. Sun, T. Tanhua, L. White, E.M.S. Woodward, P. Worsfold, P. Yeats, T. Yoshimura, A. Youenou, J. Z. Zhang, 2008: 2006 Intercomparison Exercise for Reference Material for Nutrients in Seawater in a Seawater Matrix, Technical Reports of the Meteorological Research Institute No. 58, 104pp.
- Gouretski, V.V. and Jancke, K. 2001. Systematic errors as the cause for an apparent deep water property variability: global analysis of the WOCE and historical hydrographic data • REVIEW ARTICLE, *Progress In Oceanography*, 48: Issue 4, 337-402.
- Grasshoff, K., Ehrhardt, M., Kremling K. et al. 1983. *Methods of seawater analysis*. 2nd rev. Weinheim: Verlag Chemie, Germany, West.
- Joyce, T. and Corry, C. 1994. Requirements for WOCE hydrographic programmed data reporting. WHP0 Publication, 90-1, Revision 2, WOCE Report No. 67/91.
- Kawano, T., Uchida, H. and Doi, T. WHP P01, P14 REVISIT DATA BOOK, (Ryoin Co., Ltd., Yokohama, 2009).
- Kirkwood, D.S. 1992. Stability of solutions of nutrient salts during storage. *Mar. Chem.*, 38 : 151-164.
- Kirkwood, D.S. Aminot, A. and Perttila, M. 1991. Report on the results of the ICES fourth intercomparison exercise for nutrients in sea water. *ICES coop. Res. Rep. Ser.*, 174.
- Mordy, C.W., Aoyama, M., Gordon, L.I., Johnson, G.C., Key, R.M., Ross, A.A., Jennings, J.C. and Wilson. J. 2000. Deep water comparison studies of the Pacific WOCE nutrient data set. *Eos Trans-American Geophysical Union*. 80 (supplement), OS43.
- Murphy, J., and Riley, J.P. 1962. *Analytica chim. Acta* 27, 31-36.
- Uchida, H. & Fukasawa, M. WHP P6, A10, I3/I4 REVISIT DATA BOOK Blue Earth Global Expedition 2003 1, 2, (Aiwa Printing Co., Ltd., Tokyo, 2005).

4.3. Dissolved Inorganic Carbon

4.3.1. Bottled-water analysis

(1) Personnel

Shigeto Nishino (JAMSTEC): Principal Investigator

Makoto Takada (MWJ): Operation Leader

Tomonori Watai (MWJ)

(2) Objective

The Arctic Ocean has a feature that Dissolved Inorganic Carbon (DIC) concentration is low because of the influence of inflow of the large amount of river water, dilution by sea-ice melt water and high biological productivity. Recently, the undersaturation of the calcium carbonate and a change of pCO₂ have been observed in the Arctic Ocean. It is considered that the change of seawater pH and decrease of calcium carbonate affect a growth of the species which forms shells of calcium carbonate. Therefore, quantitative understanding of the cause of these changes is necessary for better assessments and future predictions. The percentage saturation of seawater in respect to calcium carbonate can be computed from DIC and Total Alkalinity (TA; ref. Section 4.4.). Accordingly, we measured DIC on-board during the MR15-03 cruise.

(3) Parameters

Dissolved Inorganic Carbon (DIC)

(4) Instruments and Methods

I. Seawater sampling

Seawater samples were collected by 12 L Niskin bottles and a bucket at 92 casts of 78 stations (total 1484 samples). Seawater was transported into a 300 mL glass bottle (SCHOTT DURAN) which was previously soaked in 5% non-phosphoric acid detergent (pH13) solution at least 3 hours, and rinsed with fresh water for 5 times and Milli-Q deionized water for 3 times. A sampling tube was connected to the Niskin bottle when the sampling was conducted. The glass bottles were filled from the bottom, without rinsing, and were overflowed for 20 seconds. They were sealed using the 29 mm polyethylene inner lids with care not to leave any bubbles in the bottle. After collecting the samples on the deck, the sampling bottles were moved to the laboratory. Prior to the analysis, 3 mL of the samples (1% of the bottle volume) was removed from the glass bottles to make a headspace. The samples were then poisoned with 100 μ L of over

saturated solution of mercury chloride within one hour after samplings. The samples were sealed with 31.9 mm polyethylene inner lids and stored in a refrigerator at approximately 5 °C until the analysis.

II. Seawater analysis

Measurements of DIC were made with total CO₂ measuring system (System D; Nippon ANS, Inc.). The system comprises of seawater dispensing system, a CO₂ extraction system and a coulometer (Model 3000, Nippon ANS, Inc.).

The seawater dispensing system has an auto-sampler (6 ports), which takes seawater from a glass bottle to a pipette of nominal 15 mL volume by PC control. The pipette was kept at 20 ± 0.05 °C by a water jacket, in which water is circulated from a thermostatic water bath (RTE10, Thermo) set at 20 °C.

The CO₂ dissolved in a seawater sample is extracted in a stripping chamber of the CO₂ extraction system by phosphoric acid (10% v/v). The stripping chamber is made approximately 25 cm long and has a fine frit at the bottom. A constant volume of acid is added to the stripping chamber from its bottom by pressurizing an acid bottle with nitrogen gas (99.9999%). A seawater sample kept in a constant volume pipette is introduced to the stripping chamber by the same method. Nitrogen gas is bubbled through a fine frit at the bottom of the stripping chamber to make the reaction well. The stripped CO₂ is carried by the nitrogen gas (flow rate of 140 mL min⁻¹) to the coulometer through a dehydrating module consists of two electronic dehumidifiers (kept at 2 °C) and a chemical desiccant (Mg(ClO₄)₂).

Measurements of system blank (phosphoric acid blank), 1.5% CO₂ standard gas in a nitrogen base, and seawater samples (6 samples) were programmed to repeat. The variation of our own made JAMSTEC DIC reference material was used to correct the signal drift results from chemical alternation of coulometer solution.

(5) Observation log

The sampling stations for DIC were shown in Fig. 4.3.1-1.

(6) Preliminary results

During the cruise, 1484 samples were analyzed for DIC. A few replicate samples were taken at most of the stations and difference between each pair of analyses was plotted on a range control chart (Fig. 4.3.1-2). The average of the differences was 0.68 μmol kg⁻¹ (n = 202), and the standard deviation was 0.62 μmol kg⁻¹ (n = 202), which indicates the analysis was accurate enough according to the Guide to the best practices

for ocean CO₂ measurements (Dickson et al., 2007).

(7) Data archives

These data obtained in this cruise will be submitted to the Data Management Group of JAMSTEC, and will be opened to the public via “Data Research System for Whole Cruise Information in JAMSTEC (DARWIN)” in JAMSTEC web site.

<<http://www.godac.jamstec.go.jp/darwin/e>>

(8) References

Dickson, A. G., Sabine, C. L., Christian J. R. (2007) Guide to the best practices for ocean CO₂ measurements; PICES Special Publication 3, 199pp

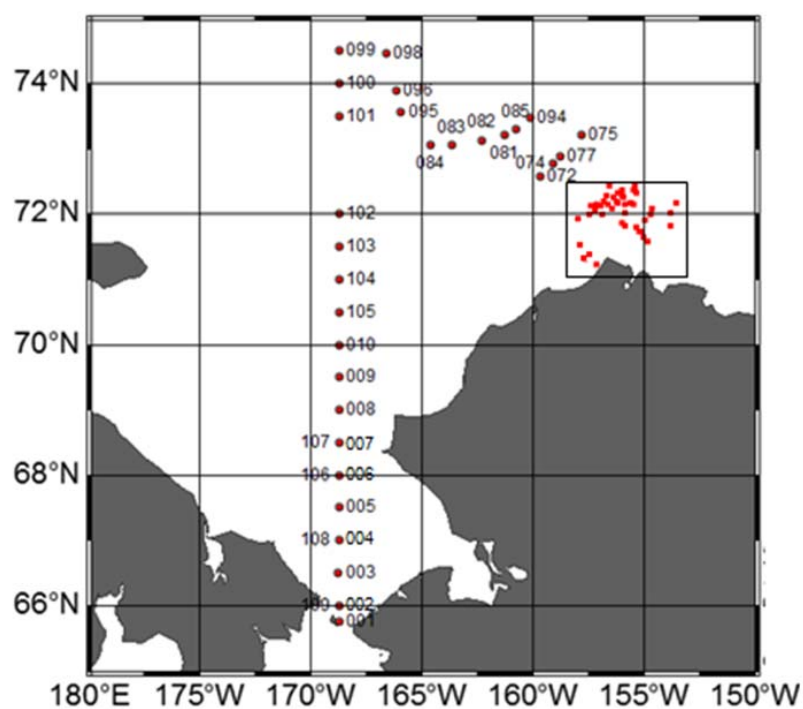

Figure 4.3.1-1 DIC sampling stations.

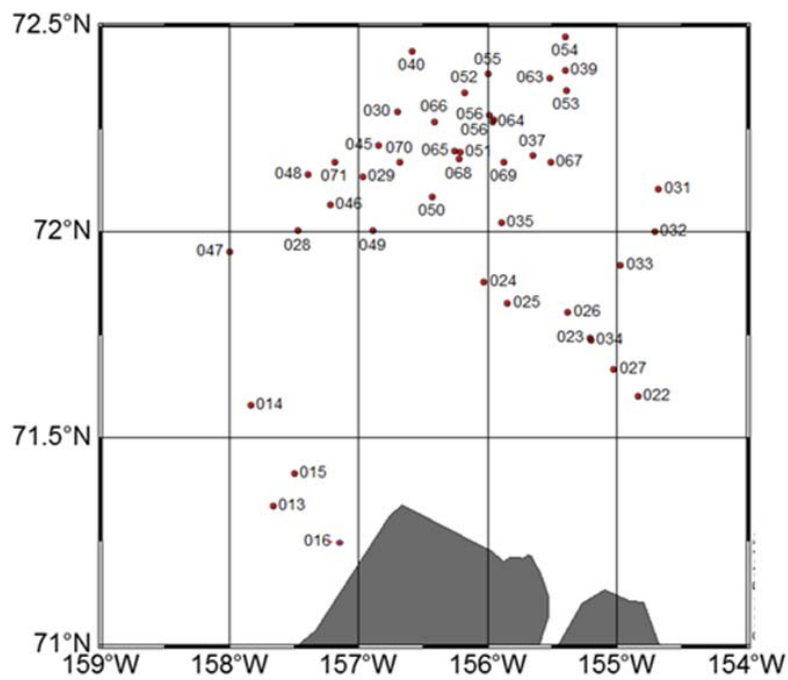

Figure 4.3.1-2 Enlarged map of selected DIC sampling stations in the boxed area of Fig. 4.3.1-1.

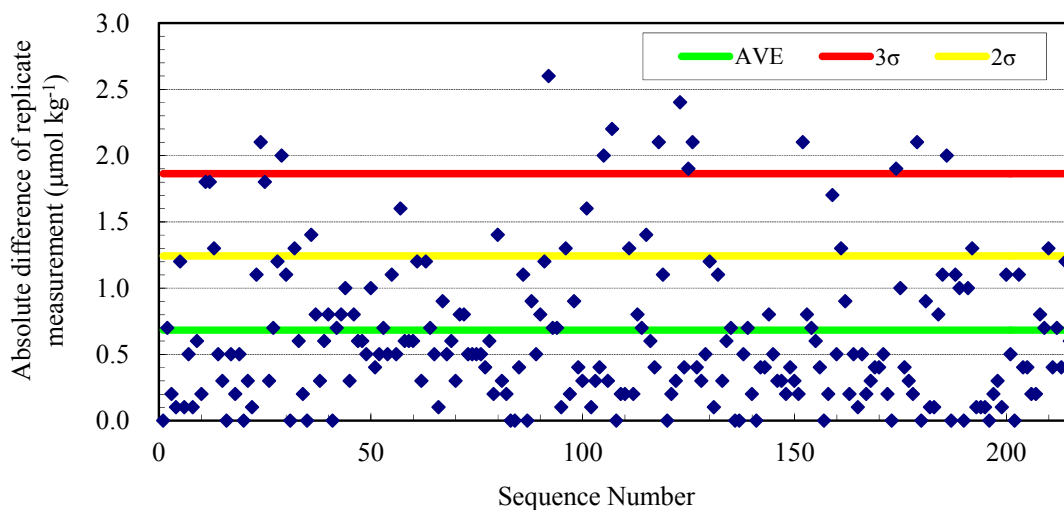

Figure 4.3.1-2 Range control chart of the absolute differences of replicate measurements carried out in the analysis of DIC during the MR15-03.

4.3.2. Underway DIC

(1) Personnel

Masao Ishii	Meteorological Research Institute / JMA: Principal Investigator
Shuji Aoki	Tohoku University
Shihiko Kameyama	Hokkaido University
Daisuke Sasano	Meteorological Research Institute / JMA
Naohiro Kosugi	Meteorological Research Institute / JMA
Hiroshi Uchida	JAMSTEC

(2) Objective

CO₂ in the atmosphere is increasing at nearly 2 μmol mol⁻¹ yr⁻¹ owing to human activities such as burning of fossil fuels, deforestation, and cement production. The ocean plays an important role in buffering the increase of atmospheric CO₂.

On the other hand, accumulation of surplus CO₂ alters budgets of ions and decreases saturation state of calcium carbonate (CaCO₃) in seawater. This phenomenon called “Ocean acidification” may be harmful to some creatures which have skeleton or shell made of CaCO₃. Furthermore, not only accumulation of CO₂ but also the dilutions of seawater by the increase of sea ice meltwater will reduce the saturation state of CaCO₃ in the Arctic Ocean. Comprehensive carbonate measurement is needed for better understanding of ocean acidification.

As for oceanic carbonate system, in case that two of 4 primary parameters (*p*CO₂, DIC, TA, and pH) were determined, we can calculate the others and additional parameters such as the saturation state of CaCO₃ and buffer factor (Revelle factor). Hence, underway DIC measurements were conducted to calculate other carbonate parameters in combination with continuous measurements of *p*CO₂ (see section 4.11.1)

(3)Parameter

Total Dissolved Inorganic Carbon (DIC)

(4) Instruments and Methods

Surface seawater was taken from an intake placed at the approximately 4.5 m below the sea surface by a pump, and was filled in a 300 ml glass bottle (SCHOTT DURAN). The glass bottles were filled from the bottom, without rinsing, and were overflowed for more than 2 times the amount. Before the analysis, the samples were put in the water bath kept about 20 deg C for one hour.

Measurements of DIC were made with total CO₂ measuring system (Nippon ANS, Inc.). The system was comprised of seawater dispensing unit, a CO₂ extraction unit, and a coulometer (Model 3000, Nippon ANS, Inc.) The seawater dispensing unit had an auto-sampler (6 ports), which dispenses the seawater from a glass bottle to a pipette of

nominal 15 ml volume. The pipette was kept at 20 ± 0.05 deg C by a water jacket, in which water circulated through a thermostatic water bath (BH201, Yamato).

Dissolved CO₂ in seawater was extracted in a stripping chamber of the CO₂ extraction unit by adding phosphoric acid (10 % v/v). The stripping chamber was made approx. 25 cm long and has a fine frit at the bottom. First, the certain amount (~2ml) of acid was taken to the constant volume tube from an acid bottle and transferred to the stripping chamber from its bottom by nitrogen gas (99.9999 %). Second, a seawater sample kept in a pipette was introduced to the stripping chamber by the same method as that for an acid. The seawater and phosphoric acid were stirred by the nitrogen bubbles through a fine frit at the bottom of the stripping chamber. The stripped CO₂ was carried to the coulometer through two electric dehumidifiers (kept at 2-10 deg C) and a chemical desiccant (Mg(ClO₄)₂) by the nitrogen gas (flow rates of 140 ml min⁻¹).

(5) Observation log

The underway measurements were conducted from 2015/8/29 (UTC) to 2015/10/6 (UTC).

(6) Calibration

During the cruise, 40 bottles of CRM (Scripps Institute of Oceanography; Batch 140) were measured in order to check a stability of the system and to determine the calibration factor.

(7) Data archives

These data obtained in this cruise will be submitted to the Data Management Group of JAMSTEC, and will be opened to the public via “Data Research System for Whole Cruise Information in JAMSTEC (DARWIN)” in JAMSTEC web site.

4.4. Total alkalinity

(1) Personnel

Shigeto Nishino (JAMSTEC): Principal Investigator

Emi Deguchi (MWJ): Operation Leader

Masanori Enoki (MWJ)

(2) Objective

As described in the Section 4.3. (DIC), total alkalinity (TA) is an essential parameter in carbonate system in the ocean. We have measured TA during the MR15-03 cruise to estimate pH, calcium carbonate saturation state and pCO₂. Furthermore, TA is a useful tracer for river water in the Arctic Ocean: TA is high in river runoff (especially in North American rivers) and low in sea ice meltwater. Because river water carries freshwater, carbon, nutrients, contaminants etc., changes in distribution of river water in the Arctic Ocean may affect regional and global climate, productivity and human health. Distribution of river water in the Chukchi Sea/Canada Basin region during the MR15-03 cruise will be estimated from TA and results will be compared with those observed in previous years.

(3) Parameters

Total alkalinity, TA

(4) Instruments and Methods

(4)-1 Seawater sampling

Seawater samples were collected at 80 stations / 94 casts in 12 L Niskin bottles mounted on the CTD-carousel system. A sampling silicone rubber with PFA tip was connected to the Niskin bottle when the sampling was carried out. The 125 ml borosilicate glass bottles (SHOTT DURAN) were filled from the bottom smoothly, without rinsing, and were overflowed for 2 times bottle volume (10 seconds) with care not to leave any bubbles in the bottle. These bottles were pre-washed by soaking in 5 % non-phosphoric acid detergent (pH = 13) for more than 3 hours and then rinsed 5 times with tap water and 3 times with Milli-Q deionized water. After collecting the samples on the deck, the bottles were carried into the lab and stored in the refrigerator until the measurement. The samples were put in the water bath kept about 25° C for one hour before the measurement.

(4)-2 Seawater analysis

Measurement of alkalinity was made using a spectrophotometric system (Nippon ANS, Inc.) using a scheme of Yao and Byrne (1998). The sampled seawater in the glass bottle is transferred to a sample cell via dispensing unit, and its temperature is kept at 25° C in a thermostatic compartment. The TA is calculated by measuring two

sets of absorbance at three wavelengths (730, 616 and 444 nm) applied by the spectrometer (TM-UV/VIS C10082CAH, HAMAMATSU). One is the absorbance of seawater sample before injecting an acid with indicator solution (bromocresol green) and another is the one after the injection. For mixing the acid with indicator solution and the seawater sufficiently, they are circulated through the line by a peristaltic pump 9 minutes before the measurement.

The TA is calculated based on the following equation:

$$\begin{aligned} \text{pH}_T = & 4.2699 + 0.002578 \times (35 - S) \\ & + \log ((R(25) - 0.00131) / (2.3148 - 0.1299 \times R(25))) \\ & - \log (1 - 0.001005 \times S), \end{aligned} \quad (1)$$

$$\begin{aligned} A_T = & (N_A \times V_A - 10^{\text{pH}_T} \times \text{DensSW}(T, S) \times (V_S + V_A)) \\ & \times (\text{DensSW}(T, S) \times V_S)^{-1}, \end{aligned} \quad (2)$$

where R(25) represents the difference of absorbance at 616 and 444 nm between before and after the injection. The absorbance of wavelength at 730 nm is used to subtract the variation of absorbance caused by the system. DensSW (T, S) is the density of seawater at temperature (T) and salinity (S), N_A the concentration of the added acid, V_A and V_S the volume of added acid and seawater, respectively.

To keep the high analysis precision, some treatments were carried out during the cruise. The acid with indicator solution stored in 1 L DURAN bottle is kept in room temperature, and about 10 mL of it is discarded at first before the batch of measurement. Furthermore, we injected the acid so that pH_T of a sample might become the range of 3.6 to 4.6 values. For mixing the seawater and the acid with indicator solution sufficiently, TYGON tube used on the peristaltic pump was periodically renewed. Absorbance measurements were done 3 times during each analysis, and each three values are averaged and used for above listed calculation for before and after the injection, respectively.

(5) Station list or Observation log

Seawater samples were collected at 80 stations / 94 casts (Figure 4.4-1, Figure 4.4-2).

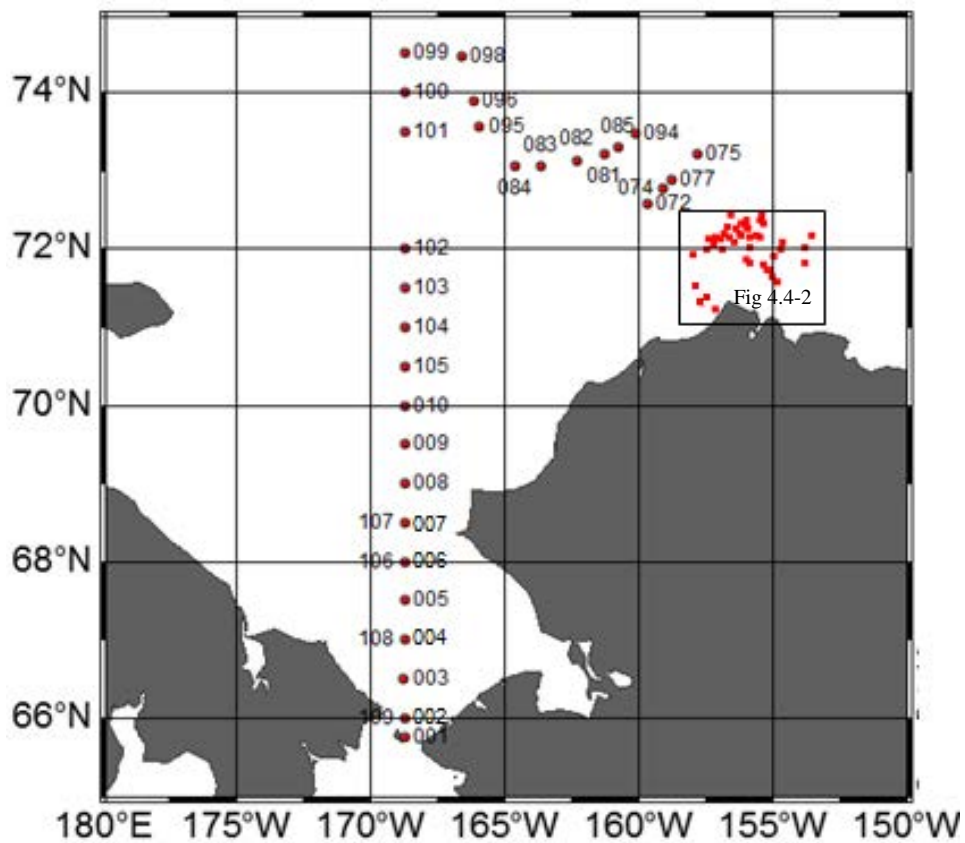

Figure 4.4-1 Map of sampling station.

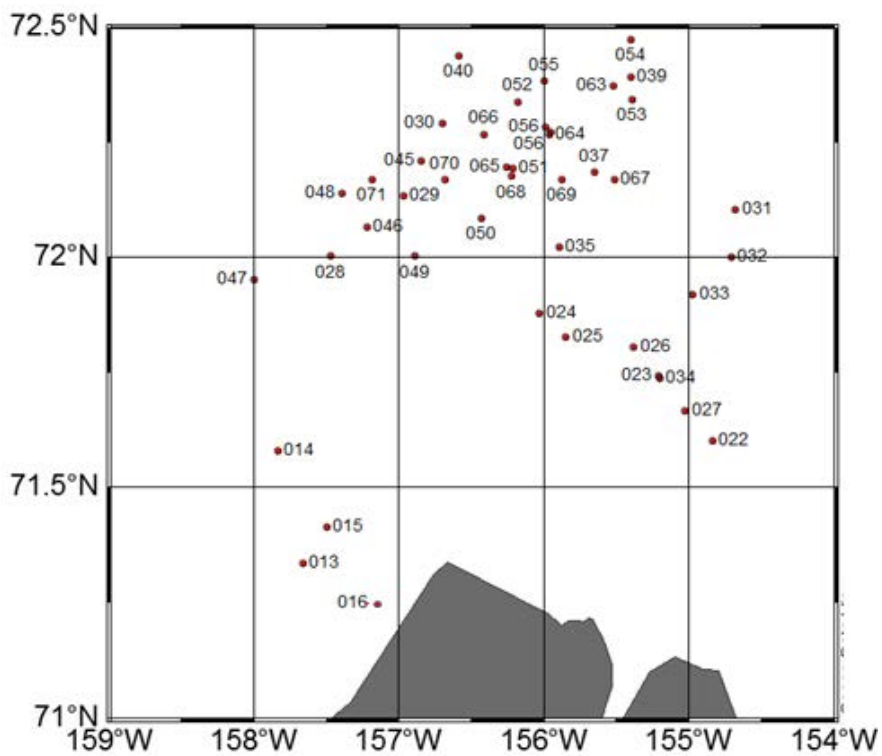

Figure 4.4-2 Enlarged Map of selected sampling station in Fig.4.4-1.

(6) Preliminary results

The repeatability of this system was $1.72 \mu\text{mol kg}^{-1}$ ($n = 19$) which was estimated from standard deviation of measured CRM value during this cruise. At each station, samples were taken in duplicate for waters of the following table 4.4-1. The difference between each pair of analyses was plotted on a range control chart (Figure 4.4-3). The average of the difference was $2.19 \mu\text{mol kg}^{-1}$ ($n = 210$ pair) with its standard deviation of $1.93 \mu\text{mol kg}^{-1}$, which indicates that the analysis was accurate enough according to Guide to best practices for ocean CO_2 measurements (Dickson et al., 2007).

Table 4.4-1 The layer taken in duplicate for waters.

Bottom depth	Duplicate layer
< 100 m	10 m, Bottom
100 - 400 m	50 m, 100 m, Bottom
> 400 m	100 m, 400 m, Bottom

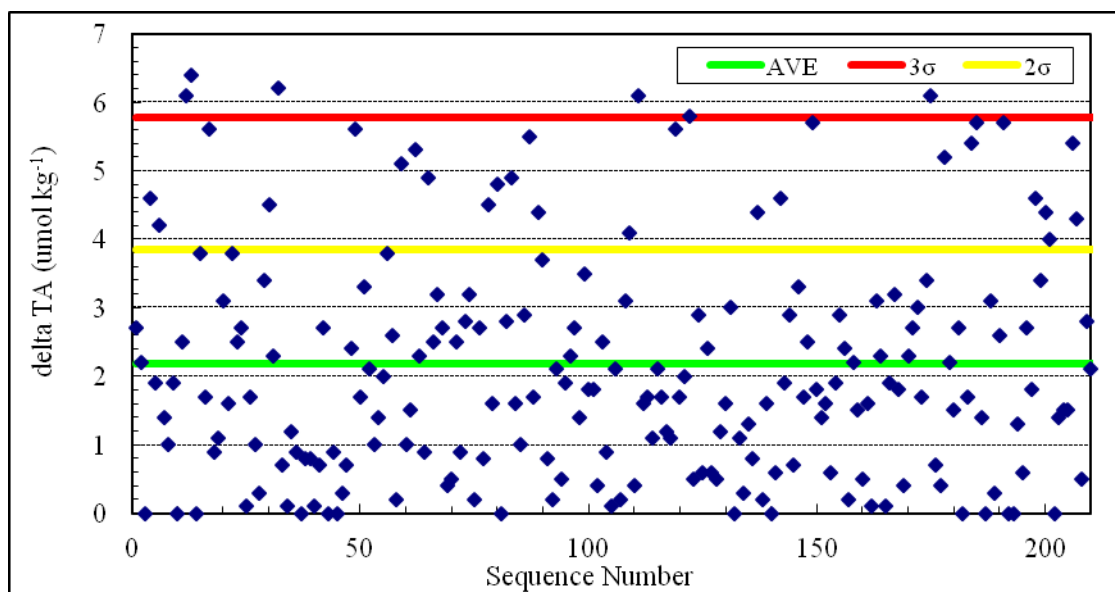

Figure 4.4-3 Range control chart of the absolute differences of duplicate measurements of TA carried out during this cruise.

(7) Data Archives

These data obtained in this cruise will be submitted to the Data Management Group of JAMSTEC, and will be opened to the public via “Data Research System for Whole Cruise Information in JAMSTEC (DARWIN)” in JAMSTEC web site.

<<http://www.godac.jamstec.go.jp/darwin/e>>

(8) References

Yao, W. and Byrne, R. H. (1998), Simplified seawater alkalinity analysis: Use of linear array spectrometers. *Deep-Sea Research Part I, Vol. 45*, 1383-1392.

Dickson, A. G., Sabine, C. L. & Christian, J. R. (2007), Guide to best practices for ocean CO₂ measurements; PICES Special Publication 3, 199

4.5. Stable isotopes of water ($\delta^{18}\text{O}$ and δD)

(1) Personnel

Hiroshi Uchida (JAMSTEC): Principal investigator
Shigeto Nishino (JAMSTEC)

(2) Objectives

Oxygen isotope ratio ($\delta^{18}\text{O}$) and hydrogen isotope ratio (δD) of seawater is a tracer to distinguish the source of freshwater between sea ice meltwater and meteoric water (river runoff and precipitation). We have collected seawater samples for $\delta^{18}\text{O}$ and δD analysis during the cruise. Results will be compared with previous observations ($\delta^{18}\text{O}$) observed during cruises of R/V Mirai in 2002, 2008, 2009, 2010 and 2014 in order to detect on-going changes in freshwater distributions in the Arctic Ocean under the recent conditions of warming and attendant increase in sea ice melt. Furthermore, a combination of $\delta^{18}\text{O}$ with total alkalinity (Section 4.4) may provide additional information about the distribution of North American river runoff because, although American and Eurasian rivers have identical oxygen isotope ratios, the total alkalinity of American river water is higher than that of Eurasian river water.

(3) Parameter

Oxygen isotope ratio ($\delta^{18}\text{O}$) and hydrogen isotope ratio (δD)

(4) Instruments and methods

Seawater samples were collected in 12L Niskin bottles mounted on the CTD-rosette system and then transferred into 10 ml glass vials for $\delta^{18}\text{O}$ and δD analysis. Samples are stored in room temperature and will be analyzed at JAMSTEC after the cruise. Results will be reported as a permil deviation of stable isotope ratio of water from that of Vienna Standard Mean Ocean Water (VSMOW):

$$\begin{aligned}\delta^{18}\text{O} [\text{‰}] &= 1000 \left\{ \frac{(^{18}\text{O}/^{16}\text{O})_{\text{sample}}}{(^{18}\text{O}/^{16}\text{O})_{\text{VSMOW}}} - 1 \right\}, \\ \delta\text{D} [\text{‰}] &= 1000 \left\{ \frac{(\text{D}/\text{H})_{\text{sample}}}{(\text{D}/\text{H})_{\text{VSMOW}}} - 1 \right\}\end{aligned}$$

(5) Observation log

The sampling list is summarized in Table 4.5-1.

(6) Data archives

These data obtained in this cruise will be submitted to the Data Management Group of JAMSTEC, and will be opened to the public via “Data Research System for Whole Cruise Information in JAMSTEC (DARWIN)” in JAMSTEC web site.

Table 4.5-1: Sampling list for $\delta^{18}\text{O}$ and δD

On board ID	Sampling Method	Date Collected				Latitude			Longitude			Depth [m]
		YYYY	MM	DD	UTC	Deg.	Min.	N/S	Deg.	Min.	E/W	
MR15-03_St001_Cast001_O18_#0001-W001	Bucket	2015	09	06	7:15	65	45.696	N	168	45.18	W	0
MR15-03_St001_Cast001_O18_#0002-W002	Niskin	2015	09	06	7:15	65	45.696	N	168	45.18	W	Chl-aMax
MR15-03_St001_Cast001_O18_#0003-W003	Niskin	2015	09	06	7:15	65	45.696	N	168	45.18	W	5
MR15-03_St001_Cast001_O18_#0004-W004	Niskin	2015	09	06	7:15	65	45.696	N	168	45.18	W	10
MR15-03_St001_Cast001_O18_#0005-W005	Niskin	2015	09	06	7:15	65	45.696	N	168	45.18	W	20
MR15-03_St001_Cast001_O18_#0006-W006	Niskin	2015	09	06	7:15	65	45.696	N	168	45.18	W	30
MR15-03_St001_Cast001_O18_#0007-W007	Niskin	2015	09	06	7:15	65	45.696	N	168	45.18	W	40
MR15-03_St001_Cast001_O18_#0008-W008	Niskin	2015	09	06	7:15	65	45.696	N	168	45.18	W	B-10
MR15-03_St001_Cast001_O18_#0009-W009	Niskin	2015	09	06	7:15	65	45.696	N	168	45.18	W	B-10
MR15-03_St002_Cast001_O18_#0010-W010	Bucket	2015	09	06	10:12	66	0.024	N	168	45.3	W	0
MR15-03_St002_Cast001_O18_#0011-W011	Niskin	2015	09	06	10:12	66	0.024	N	168	45.3	W	Chl-aMax
MR15-03_St002_Cast001_O18_#0012-W012	Niskin	2015	09	06	10:12	66	0.024	N	168	45.3	W	5
MR15-03_St002_Cast001_O18_#0013-W013	Niskin	2015	09	06	10:12	66	0.024	N	168	45.3	W	10
MR15-03_St002_Cast001_O18_#0014-W014	Niskin	2015	09	06	10:12	66	0.024	N	168	45.3	W	20
MR15-03_St002_Cast001_O18_#0015-W015	Niskin	2015	09	06	10:12	66	0.024	N	168	45.3	W	30
MR15-03_St002_Cast001_O18_#0016-W016	Niskin	2015	09	06	10:12	66	0.024	N	168	45.3	W	40
MR15-03_St002_Cast001_O18_#0017-W017	Niskin	2015	09	06	10:12	66	0.024	N	168	45.3	W	B-10
MR15-03_St002_Cast001_O18_#0018-W018	Niskin	2015	09	06	10:12	66	0.024	N	168	45.3	W	B-10
MR15-03_St003_Cast001_O18_#0019-W019	Bucket	2015	09	06	13:45	66	30.06	N	168	45.43	W	0
MR15-03_St003_Cast001_O18_#0020-W020	Niskin	2015	09	06	13:45	66	30.06	N	168	45.43	W	Chl-aMax
MR15-03_St003_Cast001_O18_#0021-W021	Niskin	2015	09	06	13:45	66	30.06	N	168	45.43	W	5
MR15-03_St003_Cast001_O18_#0022-W022	Niskin	2015	09	06	13:45	66	30.06	N	168	45.43	W	10
MR15-03_St003_Cast001_O18_#0023-W023	Niskin	2015	09	06	13:45	66	30.06	N	168	45.43	W	20
MR15-03_St003_Cast001_O18_#0024-W024	Niskin	2015	09	06	13:45	66	30.06	N	168	45.43	W	30
MR15-03_St003_Cast001_O18_#0025-W025	Niskin	2015	09	06	13:45	66	30.06	N	168	45.43	W	40
MR15-03_St003_Cast001_O18_#0026-W026	Niskin	2015	09	06	13:45	66	30.06	N	168	45.43	W	B-10
MR15-03_St003_Cast001_O18_#0027-W027	Niskin	2015	09	06	13:45	66	30.06	N	168	45.43	W	B-10
MR15-03_St004_Cast001_O18_#0028-W028	Bucket	2015	09	06	16:52	67	00.08	N	168	44.99	W	0
MR15-03_St004_Cast001_O18_#0029-W029	Niskin	2015	09	06	16:52	67	00.08	N	168	44.99	W	Chl-aMax
MR15-03_St004_Cast001_O18_#0030-W030	Niskin	2015	09	06	16:52	67	00.08	N	168	44.99	W	5
MR15-03_St004_Cast001_O18_#0031-W031	Niskin	2015	09	06	16:52	67	00.08	N	168	44.99	W	10
MR15-03_St004_Cast001_O18_#0032-W032	Niskin	2015	09	06	16:52	67	00.08	N	168	44.99	W	20
MR15-03_St004_Cast001_O18_#0033-W033	Niskin	2015	09	06	16:52	67	00.08	N	168	44.99	W	30
MR15-03_St004_Cast001_O18_#0034-W034	Niskin	2015	09	06	16:52	67	00.08	N	168	44.99	W	Not sampled

MR15-03_St004_Cast001_O18_#0035-W035	Niskin	2015	09	06	16:52	67	00.08	N	168	44.99	W	B-10
MR15-03_St004_Cast001_O18_#0036-W036	Niskin	2015	09	06	17:52	68	00.09	N	169	44.100	W	B-10
MR15-03_St005_Cast001_O18_#0037-W037	Bucket	2015	09	06	20:55	67	30.02	N	168	45.12	W	0
MR15-03_St005_Cast001_O18_#0038-W038	Niskin	2015	09	06	20:55	67	30.02	N	168	45.12	W	Chl-aMax
MR15-03_St005_Cast001_O18_#0039-W039	Niskin	2015	09	06	20:55	67	30.02	N	168	45.12	W	5
MR15-03_St005_Cast001_O18_#0040-W040	Niskin	2015	09	06	20:55	67	30.02	N	168	45.12	W	10
MR15-03_St005_Cast001_O18_#0041-W041	Niskin	2015	09	06	20:55	67	30.02	N	168	45.12	W	20
MR15-03_St005_Cast001_O18_#0042-W042	Niskin	2015	09	06	20:55	67	30.02	N	168	45.12	W	30
MR15-03_St005_Cast001_O18_#0043-W043	Niskin	2015	09	06	20:55	67	30.02	N	168	45.12	W	40
MR15-03_St005_Cast001_O18_#0044-W044	Niskin	2015	09	06	20:55	67	30.02	N	168	45.12	W	B-10
MR15-03_St005_Cast001_O18_#0045-W045	Niskin	2015	09	06	20:55	67	30.02	N	168	45.12	W	B-10
MR15-03_St006_Cast002_O18_#0046-W046	Bucket	2015	09	06	2:11	67	59.91	N	168	46.644	W	0
MR15-03_St006_Cast002_O18_#0047-W047	Niskin	2015	09	06	2:11	67	59.91	N	168	46.644	W	Chl-aMax
MR15-03_St006_Cast002_O18_#0048-W048	Niskin	2015	09	06	2:11	67	59.91	N	168	46.644	W	5
MR15-03_St006_Cast002_O18_#0049-W049	Niskin	2015	09	06	2:11	67	59.91	N	168	46.644	W	10
MR15-03_St006_Cast002_O18_#0050-W050	Niskin	2015	09	06	2:11	67	59.91	N	168	46.644	W	20
MR15-03_St006_Cast002_O18_#0051-W051	Niskin	2015	09	06	2:11	67	59.91	N	168	46.644	W	30
MR15-03_St006_Cast002_O18_#0052-W052	Niskin	2015	09	06	2:11	67	59.91	N	168	46.644	W	40
MR15-03_St006_Cast002_O18_#0053-W053	Niskin	2015	09	06	2:11	67	59.91	N	168	46.644	W	B-10
MR15-03_St006_Cast002_O18_#0054-W054	Niskin	2015	09	06	2:11	67	59.91	N	168	46.644	W	B-10
MR15-03_St007_Cast001_O18_#0055-W055	Bucket	2015	09	06	6:16	68	30.012	N	168	45.108	W	0
MR15-03_St007_Cast001_O18_#0056-W056	Niskin	2015	09	06	6:16	68	30.012	N	168	45.108	W	Chl-aMax
MR15-03_St007_Cast001_O18_#0058-W057	Niskin	2015	09	06	6:16	68	30.012	N	168	45.108	W	5
MR15-03_St007_Cast001_O18_#0058-W058	Niskin	2015	09	06	6:16	68	30.012	N	168	45.108	W	10
MR15-03_St007_Cast001_O18_#0059-W059	Niskin	2015	09	06	6:16	68	30.012	N	168	45.108	W	20
MR15-03_St007_Cast001_O18_#0060-W060	Niskin	2015	09	06	6:16	68	30.012	N	168	45.108	W	30
MR15-03_St007_Cast001_O18_#0061-W061	Niskin	2015	09	06	6:16	68	30.012	N	168	45.108	W	40
MR15-03_St007_Cast001_O18_#0062-W062	Niskin	2015	09	06	6:16	68	30.012	N	168	45.108	W	B-10
MR15-03_St007_Cast001_O18_#0063-W063	Niskin	2015	09	06	6:16	68	30.012	N	168	45.108	W	B-10
MR15-03_St008_Cast001_O18_#0064-W064	Bucket	2015	09	06	9:44	69	00.04	N	168	44.86	W	0
MR15-03_St008_Cast001_O18_#0065-W065	Niskin	2015	09	06	9:44	69	00.04	N	168	44.86	W	Chl-aMax
MR15-03_St008_Cast001_O18_#0066-W066	Niskin	2015	09	06	9:44	69	00.04	N	168	44.86	W	5
MR15-03_St008_Cast001_O18_#0067-W067	Niskin	2015	09	06	9:44	69	00.04	N	168	44.86	W	10
MR15-03_St008_Cast001_O18_#0068-W068	Niskin	2015	09	06	9:44	69	00.04	N	168	44.86	W	20
MR15-03_St008_Cast001_O18_#0069-W069	Niskin	2015	09	06	9:44	69	00.04	N	168	44.86	W	30
MR15-03_St008_Cast001_O18_#0070-W070	Niskin	2015	09	06	9:44	69	00.04	N	168	44.86	W	40
MR15-03_St008_Cast001_O18_#0071-W071	Niskin	2015	09	06	9:44	69	00.04	N	168	44.86	W	B-10
MR15-03_St008_Cast001_O18_#0072-W072	Niskin	2015	09	06	9:44	69	00.04	N	168	44.86	W	B-10

MR15-03_St009_Cast001_O18_#0073-W073	Bucket	2015	09	06	14:04	69	30.04	N	168	44.91	W	0
MR15-03_St009_Cast001_O18_#0074-W074	Niskin	2015	09	06	14:04	69	30.04	N	168	44.91	W	Chl-aMax
MR15-03_St009_Cast001_O18_#0075-W075	Niskin	2015	09	06	14:04	69	30.04	N	168	44.91	W	5
MR15-03_St009_Cast001_O18_#0076-W076	Niskin	2015	09	06	14:04	69	30.04	N	168	44.91	W	10
MR15-03_St009_Cast001_O18_#0077-W077	Niskin	2015	09	06	14:04	69	30.04	N	168	44.91	W	20
MR15-03_St009_Cast001_O18_#0078-W078	Niskin	2015	09	06	14:04	69	30.04	N	168	44.91	W	30
MR15-03_St009_Cast001_O18_#0079-W079	Niskin	2015	09	06	14:04	69	30.04	N	168	44.91	W	40
MR15-03_St009_Cast001_O18_#0080-W080	Niskin	2015	09	06	14:04	69	30.04	N	168	44.91	W	B-10
MR15-03_St009_Cast001_O18_#0081-W081	Niskin	2015	09	06	14:04	69	30.04	N	168	44.91	W	B-10
MR15-03_St010_Cast001_O18_#0082-W082	Bucket	2015	09	06	17:16	69	59.97	N	168	44.96	W	0
MR15-03_St010_Cast001_O18_#0083-W083	Niskin	2015	09	06	17:16	69	59.97	N	168	44.96	W	Chl-aMax
MR15-03_St010_Cast001_O18_#0084-W084	Niskin	2015	09	06	17:16	69	59.97	N	168	44.96	W	5
MR15-03_St010_Cast001_O18_#0085-W085	Niskin	2015	09	06	17:16	69	59.97	N	168	44.96	W	10
MR15-03_St010_Cast001_O18_#0086-W086	Niskin	2015	09	06	17:16	69	59.97	N	168	44.96	W	20
MR15-03_St010_Cast001_O18_#0087-W087	Niskin	2015	09	06	17:16	69	59.97	N	168	44.96	W	30
MR15-03_St010_Cast001_O18_#0088-W088	Niskin	2015	09	06	17:16	69	59.97	N	168	44.96	W	Not sampled
MR15-03_St010_Cast001_O18_#0089-W089	Niskin	2015	09	06	17:16	69	59.97	N	168	44.96	W	B-10
MR15-03_St010_Cast001_O18_#0090-W090	Niskin	2015	09	06	17:16	69	59.97	N	168	44.96	W	B-10
MR15-03_St011_Cast001_O18_#0091-W091	Bucket	2015	09	07	21:42	70	30.09	N	168	45.13	W	0
MR15-03_St011_Cast001_O18_#0092-W092	Niskin	2015	09	07	21:42	70	30.09	N	168	45.13	W	Chl-aMax
MR15-03_St011_Cast001_O18_#0093-W093	Niskin	2015	09	07	21:42	70	30.09	N	168	45.13	W	5
MR15-03_St011_Cast001_O18_#0094-W094	Niskin	2015	09	07	21:42	70	30.09	N	168	45.13	W	10
MR15-03_St011_Cast001_O18_#0095-W095	Niskin	2015	09	07	21:42	70	30.09	N	168	45.13	W	20
MR15-03_St011_Cast001_O18_#0096-W096	Niskin	2015	09	07	21:42	70	30.09	N	168	45.13	W	30
MR15-03_St011_Cast001_O18_#0097-W097	Niskin	2015	09	07	21:42	70	30.09	N	168	45.13	W	B-10
MR15-03_St011_Cast001_O18_#0098-W098	Niskin	2015	09	07	21:42	70	30.09	N	168	45.13	W	B-10
MR15-03_St012_Cast001_O18_#0099-W099	Bucket	2015	09	08	1:48	70	59.95	N	168	45.12	W	0
MR15-03_St012_Cast001_O18_#0100-W100	Niskin	2015	09	08	1:48	70	59.95	N	168	45.12	W	Chl-aMax
MR15-03_St012_Cast001_O18_#0101-W101	Niskin	2015	09	08	1:48	70	59.95	N	168	45.12	W	5
MR15-03_St012_Cast001_O18_#0102-W102	Niskin	2015	09	08	1:48	70	59.95	N	168	45.12	W	10
MR15-03_St012_Cast001_O18_#0103-W103	Niskin	2015	09	08	1:48	70	59.95	N	168	45.12	W	20
MR15-03_St012_Cast001_O18_#0104-W104	Niskin	2015	09	08	1:48	70	59.95	N	168	45.12	W	30
MR15-03_St012_Cast001_O18_#0105-W105	Niskin	2015	09	08	1:48	70	59.95	N	168	45.12	W	B-10
MR15-03_St012_Cast001_O18_#0106-W106	Niskin	2015	09	08	1:48	70	59.95	N	168	45.12	W	B-10
MR15-03_St015_Cast001_O18_#0107-W107	Bucket	2015	09	09	4:53	71	24.82	N	157	30.04	W	0
MR15-03_St015_Cast001_O18_#0108-W108	Niskin	2015	09	09	4:53	71	24.82	N	157	30.04	W	Chl-aMax
MR15-03_St015_Cast001_O18_#0109-W109	Niskin	2015	09	09	4:53	71	24.82	N	157	30.04	W	5
MR15-03_St015_Cast001_O18_#0110-W110	Niskin	2015	09	09	4:53	71	24.82	N	157	30.04	W	10

MR15-03_St015_Cast001_O18_#0111-W111	Niskin	2015	09	09	4:53	71	24.82	N	157	30.04	W	20
MR15-03_St015_Cast001_O18_#0112-W112	Niskin	2015	09	09	4:53	71	24.82	N	157	30.04	W	30
MR15-03_St015_Cast001_O18_#0113-W113	Niskin	2015	09	09	4:53	71	24.82	N	157	30.04	W	40
MR15-03_St015_Cast001_O18_#0114-W114	Niskin	2015	09	09	4:53	71	24.82	N	157	30.04	W	50
MR15-03_St015_Cast001_O18_#0115-W115	Niskin	2015	09	09	4:53	71	24.82	N	157	30.04	W	75
MR15-03_St015_Cast001_O18_#0116-W116	Niskin	2015	09	09	4:53	71	24.82	N	157	30.04	W	100
MR15-03_St015_Cast001_O18_#0117-W117	Niskin	2015	09	09	4:53	71	24.82	N	157	30.04	W	B-10
MR15-03_St015_Cast001_O18_#0118-W118	Niskin	2015	09	09	4:53	71	24.82	N	157	30.04	W	B-10
MR15-03_St022_Cast001_O18_#0119-W119	Bucket	2015	09	11	15:36	71	35.99	N	154	50.22	W	0
MR15-03_St022_Cast001_O18_#0120-W120	Niskin	2015	09	11	15:36	71	35.99	N	154	50.22	W	Chl-aMax
MR15-03_St022_Cast001_O18_#0121-W121	Niskin	2015	09	11	15:36	71	35.99	N	154	50.22	W	5
MR15-03_St022_Cast001_O18_#0122-W122	Niskin	2015	09	11	15:36	71	35.99	N	154	50.22	W	10
MR15-03_St022_Cast001_O18_#0123-W123	Niskin	2015	09	11	15:36	71	35.99	N	154	50.22	W	20
MR15-03_St022_Cast001_O18_#0124-W124	Niskin	2015	09	11	15:36	71	35.99	N	154	50.22	W	30
MR15-03_St022_Cast001_O18_#0125-W125	Niskin	2015	09	11	15:36	71	35.99	N	154	50.22	W	B-10
MR15-03_St023_Cast001_O18_#0126-W126	Niskin	2015	09	11	15:36	71	35.99	N	154	50.22	W	B-10
MR15-03_St023_Cast001_O18_#0127-W127	Bucket	2015	09	11	18:28	71	44.44	N	155	12.65	W	0
MR15-03_St023_Cast001_O18_#0128-W128	Niskin	2015	09	11	18:28	71	44.44	N	155	12.65	W	Chl-aMax
MR15-03_St023_Cast001_O18_#0129-W129	Niskin	2015	09	11	18:28	71	44.44	N	155	12.65	W	5
MR15-03_St023_Cast001_O18_#0126-W130	Niskin	2015	09	11	18:28	71	44.44	N	155	12.65	W	10
MR15-03_St023_Cast001_O18_#0131-W131	Niskin	2015	09	11	18:28	71	44.44	N	155	12.65	W	20
MR15-03_St023_Cast001_O18_#0132-W132	Niskin	2015	09	11	18:28	71	44.44	N	155	12.65	W	30
MR15-03_St023_Cast001_O18_#0133-W133	Niskin	2015	09	11	18:28	71	44.44	N	155	12.65	W	40
MR15-03_St023_Cast001_O18_#0134-W134	Niskin	2015	09	11	18:28	71	44.44	N	155	12.65	W	50
MR15-03_St023_Cast001_O18_#0135-W135	Niskin	2015	09	11	18:28	71	44.44	N	155	12.65	W	75
MR15-03_St023_Cast001_O18_#0136-W136	Niskin	2015	09	11	18:28	71	44.44	N	155	12.65	W	100
MR15-03_St023_Cast001_O18_#0137-W137	Niskin	2015	09	11	18:28	71	44.44	N	155	12.65	W	125
MR15-03_St023_Cast001_O18_#0138-W138	Niskin	2015	09	11	18:28	71	44.44	N	155	12.65	W	150
MR15-03_St023_Cast001_O18_#0139-W139	Niskin	2015	09	11	18:28	71	44.44	N	155	12.65	W	175
MR15-03_St023_Cast001_O18_#0140-W140	Niskin	2015	09	11	18:28	71	44.44	N	155	12.65	W	200
MR15-03_St023_Cast001_O18_#0141-W141	Niskin	2015	09	11	18:28	71	44.44	N	155	12.65	W	225
MR15-03_St023_Cast001_O18_#0142-W142	Niskin	2015	09	11	18:28	71	44.44	N	155	12.65	W	250
MR15-03_St023_Cast001_O18_#0143-W143	Niskin	2015	09	11	18:28	71	44.44	N	155	12.65	W	B-10
MR15-03_St023_Cast001_O18_#0144-W144	Niskin	2015	09	11	18:28	71	44.44	N	155	12.65	W	B-10
MR15-03_St024_Cast001_O18_#0145-W145	Bucket	2015	09	11	22:45	71	52.67	N	156	01.78	W	0
MR15-03_St024_Cast001_O18_#0146-W146	Niskin	2015	09	11	22:45	71	52.67	N	156	01.78	W	Chl-aMax
MR15-03_St024_Cast001_O18_#0147-W147	Niskin	2015	09	11	22:45	71	52.67	N	156	01.78	W	5
MR15-03_St024_Cast001_O18_#0148-W148	Niskin	2015	09	11	22:45	71	52.67	N	156	01.78	W	10

MR15-03_St024_Cast001_O18_#0149-W149	Niskin	2015	09	11	22:45	71	52.67	N	156	01.78	W	20
MR15-03_St024_Cast001_O18_#0150-W150	Niskin	2015	09	11	22:45	71	52.67	N	156	01.78	W	30
MR15-03_St024_Cast001_O18_#0151-W151	Niskin	2015	09	11	22:45	71	52.67	N	156	01.78	W	40
MR15-03_St024_Cast001_O18_#0152-W152	Niskin	2015	09	11	22:45	71	52.67	N	156	01.78	W	50
MR15-03_St024_Cast001_O18_#0153-W153	Niskin	2015	09	11	22:45	71	52.67	N	156	01.78	W	B-10
MR15-03_St024_Cast001_O18_#0154-W154	Niskin	2015	09	11	22:45	71	52.67	N	156	01.78	W	B-10
MR15-03_St025_Cast001_O18_#0155-W155	Bucket	2015	09	12	1:23	71	49.50	N	155	50.76	W	0
MR15-03_St025_Cast001_O18_#0156-W156	Niskin	2015	09	12	1:23	71	49.50	N	155	50.76	W	Chl-aMax
MR15-03_St025_Cast001_O18_#0157-W157	Niskin	2015	09	12	1:23	71	49.50	N	155	50.76	W	5
MR15-03_St025_Cast001_O18_#0158-W158	Niskin	2015	09	12	1:23	71	49.50	N	155	50.76	W	10
MR15-03_St025_Cast001_O18_#0159-W159	Niskin	2015	09	12	1:23	71	49.50	N	155	50.76	W	20
MR15-03_St025_Cast001_O18_#0160-W160	Niskin	2015	09	12	1:23	71	49.50	N	155	50.76	W	30
MR15-03_St025_Cast001_O18_#0161-W161	Niskin	2015	09	12	1:23	71	49.50	N	155	50.76	W	40
MR15-03_St025_Cast001_O18_#0162-W162	Niskin	2015	09	12	1:23	71	49.50	N	155	50.76	W	50
MR15-03_St025_Cast001_O18_#0163-W163	Niskin	2015	09	12	1:23	71	49.50	N	155	50.76	W	75
MR15-03_St025_Cast001_O18_#0164-W164	Niskin	2015	09	12	1:23	71	49.50	N	155	50.76	W	B-10
MR15-03_St025_Cast001_O18_#0165-W165	Niskin	2015	09	12	1:23	71	49.50	N	155	50.76	W	B-10
MR15-03_St026_Cast001_O18_#0166-W166	Bucket	2015	09	12	3:50	71	48.26	N	155	22.71	W	0
MR15-03_St026_Cast001_O18_#0167-W167	Niskin	2015	09	12	3:50	71	48.26	N	155	22.71	W	Chl-aMax
MR15-03_St026_Cast001_O18_#0168-W168	Niskin	2015	09	12	3:50	71	48.26	N	155	22.71	W	5
MR15-03_St026_Cast001_O18_#0169-W169	Niskin	2015	09	12	3:50	71	48.26	N	155	22.71	W	10
MR15-03_St026_Cast001_O18_#0170-W170	Niskin	2015	09	12	3:50	71	48.26	N	155	22.71	W	20
MR15-03_St026_Cast001_O18_#0171-W171	Niskin	2015	09	12	3:50	71	48.26	N	155	22.71	W	30
MR15-03_St026_Cast001_O18_#0172-W172	Niskin	2015	09	12	3:50	71	48.26	N	155	22.71	W	40
MR15-03_St026_Cast001_O18_#0173-W173	Niskin	2015	09	12	3:50	71	48.26	N	155	22.71	W	50
MR15-03_St026_Cast001_O18_#0174-W174	Niskin	2015	09	12	3:50	71	48.26	N	155	22.71	W	75
MR15-03_St026_Cast001_O18_#0175-W175	Niskin	2015	09	12	3:50	71	48.26	N	155	22.71	W	100
MR15-03_St026_Cast001_O18_#0176-W176	Niskin	2015	09	12	3:50	71	48.26	N	155	22.71	W	125
MR15-03_St026_Cast001_O18_#0177-W177	Niskin	2015	09	12	3:50	71	48.26	N	155	22.71	W	B-10
MR15-03_St026_Cast001_O18_#0178-W178	Niskin	2015	09	12	3:50	71	48.26	N	155	22.71	W	B-10
MR15-03_St027_Cast001_O18_#0179-W179	Bucket	2015	09	12	7:01	71	39.95	N	155	01.41	W	0
MR15-03_St027_Cast001_O18_#0180-W180	Niskin	2015	09	12	7:01	71	39.95	N	155	01.41	W	Chl-aMax
MR15-03_St027_Cast001_O18_#0181-W181	Niskin	2015	09	12	7:01	71	39.95	N	155	01.41	W	5
MR15-03_St027_Cast001_O18_#0182-W182	Niskin	2015	09	12	7:01	71	39.95	N	155	01.41	W	10
MR15-03_St027_Cast001_O18_#0183-W183	Niskin	2015	09	12	7:01	71	39.95	N	155	01.41	W	20
MR15-03_St027_Cast001_O18_#0184-W184	Niskin	2015	09	12	7:01	71	39.95	N	155	01.41	W	30
MR15-03_St027_Cast001_O18_#0185-W185	Niskin	2015	09	12	7:01	71	39.95	N	155	01.41	W	40
MR15-03_St027_Cast001_O18_#0186-W186	Niskin	2015	09	12	7:01	71	39.95	N	155	01.41	W	50

MR15-03_St027_Cast001_O18_#0187-W187	Niskin	2015	09	12	7:01	71	39.95	N	155	01.41	W	75
MR15-03_St027_Cast001_O18_#0188-W188	Niskin	2015	09	12	7:01	71	39.95	N	155	01.41	W	B-10
MR15-03_St027_Cast001_O18_#0189-W189	Niskin	2015	09	12	7:01	71	39.95	N	155	01.41	W	B-10
MR15-03_St028_Cast001_O18_#0190-W190	Bucket	2015	09	12	16:18	72	00.06	N	157	28.04	W	0
MR15-03_St028_Cast001_O18_#0191-W191	Niskin	2015	09	12	16:18	72	00.06	N	157	28.04	W	Chl-aMax
MR15-03_St028_Cast001_O18_#0192-W192	Niskin	2015	09	12	16:18	72	00.06	N	157	28.04	W	5
MR15-03_St028_Cast001_O18_#0193-W193	Niskin	2015	09	12	16:18	72	00.06	N	157	28.04	W	10
MR15-03_St028_Cast001_O18_#0194-W194	Niskin	2015	09	12	16:18	72	00.06	N	157	28.04	W	20
MR15-03_St028_Cast001_O18_#0195-W195	Niskin	2015	09	12	16:18	72	00.06	N	157	28.04	W	30
MR15-03_St028_Cast001_O18_#0196-W196	Niskin	2015	09	12	16:18	72	00.06	N	157	28.04	W	40
MR15-03_St028_Cast001_O18_#0197-W197	Niskin	2015	09	12	16:18	72	00.06	N	157	28.04	W	50
MR15-03_St028_Cast001_O18_#0198-W198	Niskin	2015	09	12	16:18	72	00.06	N	157	28.04	W	Not sampled
MR15-03_St028_Cast001_O18_#0199-W199	Niskin	2015	09	12	16:18	72	00.06	N	157	28.04	W	B-10
MR15-03_St028_Cast001_O18_#0200-W200	Niskin	2015	09	12	16:18	72	00.06	N	157	28.04	W	B-10
MR15-03_St029_Cast001_O18_#0201-W201	Bucket	2015	09	12	18:44	72	07.94	N	156	58.04	W	0
MR15-03_St029_Cast001_O18_#0202-W202	Niskin	2015	09	12	18:44	72	07.94	N	156	58.04	W	Chl-aMax
MR15-03_St029_Cast001_O18_#0203-W203	Niskin	2015	09	12	18:44	72	07.94	N	156	58.04	W	5
MR15-03_St029_Cast001_O18_#0204-W204	Niskin	2015	09	12	18:44	72	07.94	N	156	58.04	W	10
MR15-03_St029_Cast001_O18_#0205-W205	Niskin	2015	09	12	18:44	72	07.94	N	156	58.04	W	20
MR15-03_St029_Cast001_O18_#0206-W206	Niskin	2015	09	12	18:44	72	07.94	N	156	58.04	W	30
MR15-03_St029_Cast001_O18_#0207-W207	Niskin	2015	09	12	18:44	72	07.94	N	156	58.04	W	40
MR15-03_St029_Cast001_O18_#0208-W208	Niskin	2015	09	12	18:44	72	07.94	N	156	58.04	W	50
MR15-03_St029_Cast001_O18_#0209-W209	Niskin	2015	09	12	18:44	72	07.94	N	156	58.04	W	75
MR15-03_St029_Cast001_O18_#0210-W210	Niskin	2015	09	12	18:44	72	07.94	N	156	58.04	W	100
MR15-03_St029_Cast001_O18_#0211-W211	Niskin	2015	09	12	18:44	72	07.94	N	156	58.04	W	Not sampled
MR15-03_St029_Cast001_O18_#0212-W212	Niskin	2015	09	12	18:44	72	07.94	N	156	58.04	W	B-10
MR15-03_St029_Cast001_O18_#0213-W213	Niskin	2015	09	12	18:44	72	07.94	N	156	58.04	W	B-10
MR15-03_St030_Cast001_O18_#0214-W214	Bucket	2015	09	12	20:55	72	17.34	N	156	42.13	W	0
MR15-03_St030_Cast001_O18_#0215-W215	Niskin	2015	09	12	20:55	72	17.34	N	156	42.13	W	Chl-aMax
MR15-03_St030_Cast001_O18_#0216-W216	Niskin	2015	09	12	20:55	72	17.34	N	156	42.13	W	5
MR15-03_St030_Cast001_O18_#0217-W217	Niskin	2015	09	12	20:55	72	17.34	N	156	42.13	W	10
MR15-03_St030_Cast001_O18_#0218-W218	Niskin	2015	09	12	20:55	72	17.34	N	156	42.13	W	20
MR15-03_St030_Cast001_O18_#0219-W219	Niskin	2015	09	12	20:55	72	17.34	N	156	42.13	W	30
MR15-03_St030_Cast001_O18_#0220-W220	Niskin	2015	09	12	20:55	72	17.34	N	156	42.13	W	40
MR15-03_St030_Cast001_O18_#0221-W221	Niskin	2015	09	12	20:55	72	17.34	N	156	42.13	W	50
MR15-03_St030_Cast001_O18_#0222-W222	Niskin	2015	09	12	20:55	72	17.34	N	156	42.13	W	75
MR15-03_St030_Cast001_O18_#0223-W223	Niskin	2015	09	12	20:55	72	17.34	N	156	42.13	W	100
MR15-03_St030_Cast001_O18_#0224-W224	Niskin	2015	09	12	20:55	72	17.34	N	156	42.13	W	125

MR15-03_St030_Cast001_O18_#0225-W225	Niskin	2015	09	12	20:55	72	17.34	N	156	42.13	W	150
MR15-03_St030_Cast001_O18_#0226-W226	Niskin	2015	09	12	20:55	72	17.34	N	156	42.13	W	175
MR15-03_St030_Cast001_O18_#0227-W227	Niskin	2015	09	12	20:55	72	17.34	N	156	42.13	W	200
MR15-03_St030_Cast001_O18_#0228-W228	Niskin	2015	09	12	20:55	72	17.34	N	156	42.13	W	225
MR15-03_St030_Cast001_O18_#0229-W229	Niskin	2015	09	12	20:55	72	17.34	N	156	42.13	W	250
MR15-03_St030_Cast001_O18_#0230-W230	Niskin	2015	09	12	20:55	72	17.34	N	156	42.13	W	Not sampled
MR15-03_St030_Cast001_O18_#0231-W231	Niskin	2015	09	12	20:55	72	17.34	N	156	42.13	W	Not sampled
MR15-03_St030_Cast001_O18_#0232-W232	Niskin	2015	09	12	20:55	72	17.34	N	156	42.13	W	Not sampled
MR15-03_St030_Cast001_O18_#0233-W233	Niskin	2015	09	12	20:55	72	17.34	N	156	42.13	W	Not sampled
MR15-03_St030_Cast001_O18_#0234-W234	Niskin	2015	09	12	20:55	72	17.34	N	156	42.13	W	B-10
MR15-03_St030_Cast001_O18_#0235-W235	Niskin	2015	09	12	20:55	72	17.34	N	156	42.13	W	B-10
MR15-03_St031_Cast001_O18_#0236-W236	Bucket	2015	09	13	19:36	72	06.21	N	154	40.63	W	0
MR15-03_St031_Cast001_O18_#0237-W237	Niskin	2015	09	13	19:36	72	06.21	N	154	40.63	W	Chl-aMax
MR15-03_St031_Cast001_O18_#0238-W238	Niskin	2015	09	13	19:36	72	06.21	N	154	40.63	W	5
MR15-03_St031_Cast001_O18_#0239-W239	Niskin	2015	09	13	19:36	72	06.21	N	154	40.63	W	10
MR15-03_St031_Cast001_O18_#0240-W240	Niskin	2015	09	13	19:36	72	06.21	N	154	40.63	W	20
MR15-03_St031_Cast001_O18_#0241-W241	Niskin	2015	09	13	19:36	72	06.21	N	154	40.63	W	30
MR15-03_St031_Cast001_O18_#0241-W242	Niskin	2015	09	13	19:36	72	06.21	N	154	40.63	W	40
MR15-03_St031_Cast001_O18_#0243-W243	Niskin	2015	09	13	19:36	72	06.21	N	154	40.63	W	50
MR15-03_St031_Cast001_O18_#0244-W244	Niskin	2015	09	13	19:36	72	06.21	N	154	40.63	W	75
MR15-03_St031_Cast001_O18_#0245-W245	Niskin	2015	09	13	19:36	72	06.21	N	154	40.63	W	100
MR15-03_St031_Cast001_O18_#0246-W246	Niskin	2015	09	13	19:36	72	06.21	N	154	40.63	W	125
MR15-03_St031_Cast001_O18_#0247-W247	Niskin	2015	09	13	19:36	72	06.21	N	154	40.63	W	150
MR15-03_St031_Cast001_O18_#0248-W248	Niskin	2015	09	13	19:36	72	06.21	N	154	40.63	W	175
MR15-03_St031_Cast001_O18_#0249-W249	Niskin	2015	09	13	19:36	72	06.21	N	154	40.63	W	200
MR15-03_St031_Cast001_O18_#0250-W250	Niskin	2015	09	13	19:36	72	06.21	N	154	40.63	W	225
MR15-03_St031_Cast001_O18_#0251-W251	Niskin	2015	09	13	19:36	72	06.21	N	154	40.63	W	250
MR15-03_St031_Cast001_O18_#0252-W252	Niskin	2015	09	13	19:36	72	06.21	N	154	40.63	W	300
MR15-03_St031_Cast001_O18_#0253-W253	Niskin	2015	09	13	19:36	72	06.21	N	154	40.63	W	400
MR15-03_St031_Cast001_O18_#0254-W254	Niskin	2015	09	13	19:36	72	06.21	N	154	40.63	W	500
MR15-03_St031_Cast001_O18_#0255-W255	Niskin	2015	09	13	19:36	72	06.21	N	154	40.63	W	600
MR15-03_St031_Cast001_O18_#0256-W256	Niskin	2015	09	13	19:36	72	06.21	N	154	40.63	W	800
MR15-03_St031_Cast001_O18_#0257-W257	Niskin	2015	09	13	19:36	72	06.21	N	154	40.63	W	1000
MR15-03_St031_Cast001_O18_#0258-W258	Niskin	2015	09	13	19:36	72	06.21	N	154	40.63	W	B-10
MR15-03_St031_Cast001_O18_#0259-W259	Niskin	2015	09	13	19:36	72	06.21	N	154	40.63	W	B-10
MR15-03_St032_Cast001_O18_#0260-W260	Bucket	2015	09	13	23:10	71	59.99	N	154	42.40	W	0
MR15-03_St032_Cast001_O18_#0261-W261	Niskin	2015	09	13	23:10	71	59.99	N	154	42.40	W	Chl-aMax
MR15-03_St032_Cast001_O18_#0262-W262	Niskin	2015	09	13	23:10	71	59.99	N	154	42.40	W	5

MR15-03_St032_Cast001_O18_#0263-W263	Niskin	2015	09	13	23:10	71	59.99	N	154	42.40	W	10
MR15-03_St032_Cast001_O18_#0264-W264	Niskin	2015	09	13	23:10	71	59.99	N	154	42.40	W	20
MR15-03_St032_Cast001_O18_#0265-W265	Niskin	2015	09	13	23:10	71	59.99	N	154	42.40	W	30
MR15-03_St032_Cast001_O18_#0266-W266	Niskin	2015	09	13	23:10	71	59.99	N	154	42.40	W	40
MR15-03_St032_Cast001_O18_#0267-W267	Niskin	2015	09	13	23:10	71	59.99	N	154	42.40	W	50
MR15-03_St032_Cast001_O18_#0268-W268	Niskin	2015	09	13	23:10	71	59.99	N	154	42.40	W	75
MR15-03_St032_Cast001_O18_#0269-W269	Niskin	2015	09	13	23:10	71	59.99	N	154	42.40	W	100
MR15-03_St032_Cast001_O18_#0270-W270	Niskin	2015	09	13	23:10	71	59.99	N	154	42.40	W	125
MR15-03_St032_Cast001_O18_#0271-W271	Niskin	2015	09	13	23:10	71	59.99	N	154	42.40	W	150
MR15-03_St032_Cast001_O18_#0272-W272	Niskin	2015	09	13	23:10	71	59.99	N	154	42.40	W	175
MR15-03_St032_Cast001_O18_#0273-W273	Niskin	2015	09	13	23:10	71	59.99	N	154	42.40	W	200
MR15-03_St032_Cast001_O18_#0274-W274	Niskin	2015	09	13	23:10	71	59.99	N	154	42.40	W	225
MR15-03_St032_Cast001_O18_#0275-W275	Niskin	2015	09	13	23:10	71	59.99	N	154	42.40	W	250
MR15-03_St032_Cast001_O18_#0276-W276	Niskin	2015	09	13	23:10	71	59.99	N	154	42.40	W	300
MR15-03_St032_Cast001_O18_#0277-W277	Niskin	2015	09	13	23:10	71	59.99	N	154	42.40	W	400
MR15-03_St032_Cast001_O18_#0278-W278	Niskin	2015	09	13	23:10	71	59.99	N	154	42.40	W	500
MR15-03_St032_Cast001_O18_#0281-W279	Niskin	2015	09	13	23:10	71	59.99	N	154	42.40	W	600
MR15-03_St032_Cast001_O18_#0282-W280	Niskin	2015	09	13	23:10	71	59.99	N	154	42.40	W	800
MR15-03_St032_Cast001_O18_#0283-W281	Niskin	2015	09	13	23:10	71	59.99	N	154	42.40	W	1000
MR15-03_St032_Cast001_O18_#0279-W282	Niskin	2015	09	13	23:10	71	59.99	N	154	42.40	W	B-10
MR15-03_St032_Cast001_O18_#0280-W283	Niskin	2015	09	13	23:10	71	59.99	N	154	42.40	W	B-10
MR15-03_St033_Cast001_O18_#0284-W284	Bucket	2015	09	14	3:17	71	55.03	N	154	58.31	W	0
MR15-03_St033_Cast001_O18_#0285-W285	Niskin	2015	09	14	3:17	71	55.03	N	154	58.31	W	Chl-aMax
MR15-03_St033_Cast001_O18_#0286-W286	Niskin	2015	09	14	3:17	71	55.03	N	154	58.31	W	5
MR15-03_St033_Cast001_O18_#0287-W287	Niskin	2015	09	14	3:17	71	55.03	N	154	58.31	W	10
MR15-03_St033_Cast001_O18_#0288-W288	Niskin	2015	09	14	3:17	71	55.03	N	154	58.31	W	20
MR15-03_St033_Cast001_O18_#0289-W289	Niskin	2015	09	14	3:17	71	55.03	N	154	58.31	W	30
MR15-03_St033_Cast001_O18_#0290-W290	Niskin	2015	09	14	3:17	71	55.03	N	154	58.31	W	40
MR15-03_St033_Cast001_O18_#0291-W291	Niskin	2015	09	14	3:17	71	55.03	N	154	58.31	W	50
MR15-03_St033_Cast001_O18_#0292-W292	Niskin	2015	09	14	3:17	71	55.03	N	154	58.31	W	75
MR15-03_St033_Cast001_O18_#0293-W293	Niskin	2015	09	14	3:17	71	55.03	N	154	58.31	W	100
MR15-03_St033_Cast001_O18_#0294-W294	Niskin	2015	09	14	3:17	71	55.03	N	154	58.31	W	125
MR15-03_St033_Cast001_O18_#0295-W295	Niskin	2015	09	14	3:17	71	55.03	N	154	58.31	W	150
MR15-03_St033_Cast001_O18_#0296-W296	Niskin	2015	09	14	3:17	71	55.03	N	154	58.31	W	175
MR15-03_St033_Cast001_O18_#0297-W297	Niskin	2015	09	14	3:17	71	55.03	N	154	58.31	W	200
MR15-03_St033_Cast001_O18_#0298-W298	Niskin	2015	09	14	3:17	71	55.03	N	154	58.31	W	225
MR15-03_St033_Cast001_O18_#0299-W299	Niskin	2015	09	14	3:17	71	55.03	N	154	58.31	W	250
MR15-03_St033_Cast001_O18_#0300-W300	Niskin	2015	09	14	3:17	71	55.03	N	154	58.31	W	300

MR15-03_St033_Cast001_O18_#0301-W301	Niskin	2015	09	14	3:17	71	55.03	N	154	58.31	W	B-10
MR15-03_St033_Cast001_O18_#0302-W302	Niskin	2015	09	14	3:17	71	55.03	N	154	58.31	W	B-10
MR15-03_St039_Cast002_O18_#0303-W303	Bucket	2015	09	14	1:28	72	23.48	N	155	24.15	W	0
MR15-03_St039_Cast002_O18_#0304-W304	Niskin	2015	09	14	1:28	72	23.48	N	155	24.15	W	Chl-aMax
MR15-03_St039_Cast002_O18_#0305-W305	Niskin	2015	09	14	1:28	72	23.48	N	155	24.15	W	5
MR15-03_St039_Cast002_O18_#0306-W306	Niskin	2015	09	14	1:28	72	23.48	N	155	24.15	W	10
MR15-03_St039_Cast002_O18_#0307-W307	Niskin	2015	09	14	1:28	72	23.48	N	155	24.15	W	20
MR15-03_St039_Cast002_O18_#0308-W308	Niskin	2015	09	14	1:28	72	23.48	N	155	24.15	W	30
MR15-03_St039_Cast002_O18_#0309-W309	Niskin	2015	09	14	1:28	72	23.48	N	155	24.15	W	40
MR15-03_St039_Cast002_O18_#0310-W310	Niskin	2015	09	14	1:28	72	23.48	N	155	24.15	W	50
MR15-03_St039_Cast002_O18_#0311-W311	Niskin	2015	09	14	1:28	72	23.48	N	155	24.15	W	75
MR15-03_St039_Cast002_O18_#0312-W312	Niskin	2015	09	14	1:28	72	23.48	N	155	24.15	W	100
MR15-03_St039_Cast002_O18_#0313-W313	Niskin	2015	09	14	1:28	72	23.48	N	155	24.15	W	125
MR15-03_St039_Cast002_O18_#0314-W314	Niskin	2015	09	14	1:28	72	23.49	N	155	24.15	W	150
MR15-03_St039_Cast002_O18_#0313-W315	Niskin	2015	09	14	1:28	72	23.50	N	155	24.15	W	175
MR15-03_St039_Cast002_O18_#0316-W316	Niskin	2015	09	14	1:28	72	23.51	N	155	24.15	W	200
MR15-03_St039_Cast002_O18_#0317-W317	Niskin	2015	09	14	1:28	72	23.52	N	155	24.15	W	225
MR15-03_St039_Cast002_O18_#0318-W318	Niskin	2015	09	14	1:28	72	23.53	N	155	24.15	W	250
MR15-03_St039_Cast002_O18_#0319-W319	Niskin	2015	09	14	1:28	72	23.54	N	155	24.15	W	300
MR15-03_St039_Cast002_O18_#0320-W320	Niskin	2015	09	14	1:28	72	23.55	N	155	24.15	W	400
MR15-03_St039_Cast002_O18_#0321-W321	Niskin	2015	09	14	1:28	72	23.56	N	155	24.15	W	500
MR15-03_St039_Cast002_O18_#0322-W322	Niskin	2015	09	14	1:28	72	23.57	N	155	24.15	W	600
MR15-03_St039_Cast002_O18_#0323-W323	Niskin	2015	09	14	1:28	72	23.58	N	155	24.15	W	800
MR15-03_St039_Cast002_O18_#0324-W324	Niskin	2015	09	14	1:28	72	23.59	N	155	24.15	W	1000
MR15-03_St039_Cast002_O18_#0325-W325	Niskin	2015	09	14	1:28	72	23.60	N	155	24.15	W	Not sampled
MR15-03_St039_Cast002_O18_#0326-W326	Niskin	2015	09	14	1:28	72	23.61	N	155	24.15	W	B-10
MR15-03_St039_Cast002_O18_#0327-W327	Niskin	2015	09	14	1:28	72	23.62	N	155	24.15	W	B-10
MR15-03_St040_Cast001_O18_#0328-W328	Bucket	2015	09	14	5:11	72	26.19	N	156	35.45	W	0
MR15-03_St040_Cast001_O18_#0329-W329	Niskin	2015	09	14	5:11	72	26.19	N	156	35.45	W	Chl-aMax
MR15-03_St040_Cast001_O18_#0330-W330	Niskin	2015	09	14	5:11	72	26.19	N	156	35.45	W	5
MR15-03_St040_Cast001_O18_#0331-W331	Niskin	2015	09	14	5:11	72	26.19	N	156	35.45	W	10
MR15-03_St040_Cast001_O18_#0332-W332	Niskin	2015	09	14	5:11	72	26.19	N	156	35.45	W	20
MR15-03_St040_Cast001_O18_#0333-W333	Niskin	2015	09	14	5:11	72	26.19	N	156	35.45	W	30
MR15-03_St040_Cast001_O18_#0334-W334	Niskin	2015	09	14	5:11	72	26.19	N	156	35.45	W	40
MR15-03_St040_Cast001_O18_#0335-W335	Niskin	2015	09	14	5:11	72	26.19	N	156	35.45	W	50
MR15-03_St040_Cast001_O18_#0336-W336	Niskin	2015	09	14	5:11	72	26.19	N	156	35.45	W	75
MR15-03_St040_Cast001_O18_#0337-W337	Niskin	2015	09	14	5:11	72	26.19	N	156	35.45	W	100
MR15-03_St040_Cast001_O18_#0338-W338	Niskin	2015	09	14	5:11	72	26.19	N	156	35.45	W	125

MR15-03_St040_Cast001_O18_#0339-W339	Niskin	2015	09	14	5:11	72	26.19	N	156	35.45	W	150
MR15-03_St040_Cast001_O18_#0340-W340	Niskin	2015	09	14	5:11	72	26.19	N	156	35.45	W	175
MR15-03_St040_Cast001_O18_#0341-W341	Niskin	2015	09	14	5:11	72	26.19	N	156	35.45	W	200
MR15-03_St040_Cast001_O18_#0342-W342	Niskin	2015	09	14	5:11	72	26.19	N	156	35.45	W	225
MR15-03_St040_Cast001_O18_#0343-W343	Niskin	2015	09	14	5:11	72	26.19	N	156	35.45	W	250
MR15-03_St040_Cast001_O18_#0344-W344	Niskin	2015	09	14	5:11	72	26.19	N	156	35.45	W	300
MR15-03_St040_Cast001_O18_#0345-W345	Niskin	2015	09	14	5:11	72	26.19	N	156	35.45	W	400
MR15-03_St040_Cast001_O18_#0346-W346	Niskin	2015	09	14	5:11	72	26.19	N	156	35.45	W	500
MR15-03_St040_Cast001_O18_#0347-W347	Niskin	2015	09	14	5:11	72	26.19	N	156	35.45	W	600
MR15-03_St040_Cast001_O18_#0348-W348	Niskin	2015	09	14	5:11	72	26.19	N	156	35.45	W	800
MR15-03_St040_Cast001_O18_#0349-W349	Niskin	2015	09	14	5:11	72	26.19	N	156	35.45	W	B-10
MR15-03_St040_Cast001_O18_#0350-W350	Niskin	2015	09	14	5:11	72	26.19	N	156	35.45	W	B-10
MR15-03_St075_Cast001_O18_#0351-W351	Bucket	2015	09	25	0:45	73	12.53	N	157	48.22	W	0
MR15-03_St075_Cast001_O18_#0352-W352	Niskin	2015	09	25	0:45	73	12.53	N	157	48.22	W	Chl-aMax
MR15-03_St075_Cast001_O18_#0353-W353	Niskin	2015	09	25	0:45	73	12.53	N	157	48.22	W	5
MR15-03_St075_Cast001_O18_#0354-W354	Niskin	2015	09	25	0:45	73	12.53	N	157	48.22	W	10
MR15-03_St075_Cast001_O18_#0355-W355	Niskin	2015	09	25	0:45	73	12.53	N	157	48.22	W	20
MR15-03_St075_Cast001_O18_#0356-W356	Niskin	2015	09	25	0:45	73	12.53	N	157	48.22	W	30
MR15-03_St075_Cast001_O18_#0357-W357	Niskin	2015	09	25	0:45	73	12.53	N	157	48.22	W	40
MR15-03_St075_Cast001_O18_#0358-W358	Niskin	2015	09	25	0:45	73	12.53	N	157	48.22	W	50
MR15-03_St075_Cast001_O18_#0359-W359	Niskin	2015	09	25	0:45	73	12.53	N	157	48.22	W	75
MR15-03_St075_Cast001_O18_#0360-W360	Niskin	2015	09	25	0:45	73	12.53	N	157	48.22	W	100
MR15-03_St075_Cast001_O18_#0361-W361	Niskin	2015	09	25	0:45	73	12.53	N	157	48.22	W	125
MR15-03_St075_Cast001_O18_#0362-W362	Niskin	2015	09	25	0:45	73	12.53	N	157	48.22	W	150
MR15-03_St075_Cast001_O18_#0363-W363	Niskin	2015	09	25	0:45	73	12.53	N	157	48.22	W	175
MR15-03_St075_Cast001_O18_#0364-W364	Niskin	2015	09	25	0:45	73	12.53	N	157	48.22	W	200
MR15-03_St075_Cast001_O18_#0365-W365	Niskin	2015	09	25	0:45	73	12.53	N	157	48.22	W	250
MR15-03_St075_Cast001_O18_#0366-W366	Niskin	2015	09	25	0:45	73	12.53	N	157	48.22	W	300
MR15-03_St075_Cast001_O18_#0367-W367	Niskin	2015	09	25	0:45	73	12.53	N	157	48.22	W	400
MR15-03_St075_Cast001_O18_#0368-W368	Niskin	2015	09	25	0:45	73	12.53	N	157	48.22	W	500
MR15-03_St075_Cast001_O18_#0369-W369	Niskin	2015	09	25	0:45	73	12.53	N	157	48.22	W	600
MR15-03_St075_Cast001_O18_#0370-W370	Niskin	2015	09	25	0:45	73	12.53	N	157	48.22	W	800
MR15-03_St075_Cast001_O18_#0371-W371	Niskin	2015	09	25	0:45	73	12.53	N	157	48.22	W	1000
MR15-03_St075_Cast001_O18_#0372-W372	Niskin	2015	09	25	0:45	73	12.53	N	157	48.22	W	1500
MR15-03_St075_Cast001_O18_#0373-W373	Niskin	2015	09	25	0:45	73	12.53	N	157	48.22	W	2000
MR15-03_St075_Cast001_O18_#0374-W374	Niskin	2015	09	25	0:45	73	12.53	N	157	48.22	W	2500
MR15-03_St075_Cast001_O18_#0375-W375	Niskin	2015	09	25	0:45	73	12.53	N	157	48.22	W	B-10
MR15-03_St075_Cast001_O18_#0376-W376	Niskin	2015	09	25	0:45	73	12.53	N	157	48.22	W	B-10

MR15-03_St085_Cast002_O18_#0377-W377	Bucket	2015	09	26	19:52	73	18.61	N	160	45.60	W	0
MR15-03_St085_Cast002_O18_#0378-W378	Niskin	2015	09	26	19:52	73	18.61	N	160	45.60	W	Chl-aMax
MR15-03_St085_Cast002_O18_#0379-W379	Niskin	2015	09	26	19:52	73	18.61	N	160	45.60	W	5
MR15-03_St085_Cast002_O18_#0380-W380	Niskin	2015	09	26	19:52	73	18.61	N	160	45.60	W	10
MR15-03_St085_Cast002_O18_#0381-W381	Niskin	2015	09	26	19:52	73	18.61	N	160	45.60	W	20
MR15-03_St085_Cast002_O18_#0382-W382	Niskin	2015	09	26	19:52	73	18.61	N	160	45.60	W	30
MR15-03_St085_Cast002_O18_#0383-W383	Niskin	2015	09	26	19:52	73	18.61	N	160	45.60	W	40
MR15-03_St085_Cast002_O18_#0384-W384	Niskin	2015	09	26	19:52	73	18.61	N	160	45.60	W	50
MR15-03_St085_Cast002_O18_#0385-W385	Niskin	2015	09	26	19:52	73	18.61	N	160	45.60	W	75
MR15-03_St085_Cast002_O18_#0386-W386	Niskin	2015	09	26	19:52	73	18.61	N	160	45.60	W	100
MR15-03_St085_Cast002_O18_#0387-W387	Niskin	2015	09	26	19:52	73	18.61	N	160	45.60	W	125
MR15-03_St085_Cast002_O18_#0388-W388	Niskin	2015	09	26	19:52	73	18.61	N	160	45.60	W	150
MR15-03_St085_Cast002_O18_#0389-W389	Niskin	2015	09	26	19:52	73	18.61	N	160	45.60	W	175
MR15-03_St085_Cast002_O18_#0390-W390	Niskin	2015	09	26	19:52	73	18.61	N	160	45.60	W	200
MR15-03_St085_Cast002_O18_#0391-W391	Niskin	2015	09	26	19:52	73	18.61	N	160	45.60	W	225
MR15-03_St085_Cast002_O18_#0392-W392	Niskin	2015	09	26	19:52	73	18.61	N	160	45.60	W	250
MR15-03_St085_Cast002_O18_#0393-W393	Niskin	2015	09	26	19:52	73	18.61	N	160	45.60	W	300
MR15-03_St085_Cast002_O18_#0394-W394	Niskin	2015	09	26	19:52	73	18.61	N	160	45.60	W	400
MR15-03_St085_Cast002_O18_#0395-W395	Niskin	2015	09	26	19:52	73	18.61	N	160	45.60	W	B-10
MR15-03_St085_Cast002_O18_#0396-W396	Niskin	2015	09	26	19:52	73	18.61	N	160	45.60	W	B-10
MR15-03_St099_Cast001_O18_#0397-W397	Bucket	2015	09	29	0:54	74	30.02	N	168	45.11	W	0
MR15-03_St099_Cast001_O18_#0398-W398	Niskin	2015	09	29	0:54	74	30.02	N	168	45.11	W	Chl-aMax
MR15-03_St099_Cast001_O18_#0399-W399	Niskin	2015	09	29	0:54	74	30.02	N	168	45.11	W	5
MR15-03_St099_Cast001_O18_#0400-W400	Niskin	2015	09	29	0:54	74	30.02	N	168	45.11	W	10
MR15-03_St099_Cast001_O18_#0401-W401	Niskin	2015	09	29	0:54	74	30.02	N	168	45.11	W	20
MR15-03_St099_Cast001_O18_#0402-W402	Niskin	2015	09	29	0:54	74	30.02	N	168	45.11	W	30
MR15-03_St099_Cast001_O18_#0403-W403	Niskin	2015	09	29	0:54	74	30.02	N	168	45.11	W	40
MR15-03_St099_Cast001_O18_#0404-W404	Niskin	2015	09	29	0:54	74	30.02	N	168	45.11	W	50
MR15-03_St099_Cast001_O18_#0405-W405	Niskin	2015	09	29	0:54	74	30.02	N	168	45.11	W	75
MR15-03_St099_Cast001_O18_#0406-W406	Niskin	2015	09	29	0:54	74	30.02	N	168	45.11	W	100
MR15-03_St099_Cast001_O18_#0407-W407	Niskin	2015	09	29	0:54	74	30.02	N	168	45.11	W	125
MR15-03_St099_Cast001_O18_#0408-W408	Niskin	2015	09	29	0:54	74	30.02	N	168	45.11	W	150
MR15-03_St099_Cast001_O18_#0409-W409	Niskin	2015	09	29	0:54	74	30.02	N	168	45.11	W	175
MR15-03_St099_Cast001_O18_#0410-W410	Niskin	2015	09	29	0:54	74	30.02	N	168	45.11	W	B-10
MR15-03_St099_Cast001_O18_#0411-W411	Niskin	2015	09	29	0:54	74	30.02	N	168	45.11	W	B-10
MR15-03_St102_Cast001_O18_#0412-W412	Bucket	2015	09	29	22:20	72	00.11	N	168	44.74	W	0
MR15-03_St102_Cast001_O18_#0413-W413	Niskin	2015	09	29	22:20	72	00.11	N	168	44.74	W	Chl-aMax
MR15-03_St102_Cast001_O18_#0414-W414	Niskin	2015	09	29	22:20	72	00.11	N	168	44.74	W	5

MR15-03_St102_Cast001_O18_#0415-W415	Niskin	2015	09	29	22:20	72	00.11	N	168	44.74	W	10
MR15-03_St102_Cast001_O18_#0416-W416	Niskin	2015	09	29	22:20	72	00.11	N	168	44.74	W	20
MR15-03_St102_Cast001_O18_#0417-W417	Niskin	2015	09	29	22:20	72	00.11	N	168	44.74	W	30
MR15-03_St102_Cast001_O18_#0418-W418	Niskin	2015	09	29	22:20	72	00.11	N	168	44.74	W	40
MR15-03_St102_Cast001_O18_#0419-W419	Niskin	2015	09	29	22:20	72	00.11	N	168	44.74	W	Not sampled
MR15-03_St102_Cast001_O18_#0420-W420	Niskin	2015	09	29	22:20	72	00.11	N	168	44.74	W	B-10
MR15-03_St102_Cast001_O18_#0421-W421	Niskin	2015	09	29	22:20	72	00.11	N	168	44.74	W	B-10
MR15-03_St103_Cast001_O18_#0422-W422	Bucket	2015	09	30	2:33	71	30.01	N	168	44.98	W	0
MR15-03_St103_Cast001_O18_#0423-W423	Niskin	2015	09	30	2:33	71	30.01	N	168	44.98	W	Chl-aMax
MR15-03_St103_Cast001_O18_#0424-W424	Niskin	2015	09	30	2:33	71	30.01	N	168	44.98	W	5
MR15-03_St103_Cast001_O18_#0425-W425	Niskin	2015	09	30	2:33	71	30.01	N	168	44.98	W	10
MR15-03_St103_Cast001_O18_#0426-W426	Niskin	2015	09	30	2:33	71	30.01	N	168	44.98	W	20
MR15-03_St103_Cast001_O18_#0427-W427	Niskin	2015	09	30	2:33	71	30.01	N	168	44.98	W	30
MR15-03_St103_Cast001_O18_#0428-W428	Niskin	2015	09	30	2:33	71	30.01	N	168	44.98	W	40
MR15-03_St103_Cast001_O18_#0429-W429	Niskin	2015	09	30	2:33	71	30.01	N	168	44.98	W	B-10
MR15-03_St103_Cast001_O18_#0430-W430	Niskin	2015	09	30	2:33	71	30.01	N	168	44.98	W	B-10
MR15-03_St104_Cast001_O18_#0431-W431	Bucket	2015	09	30	6:21	70	59.92	N	168	44.81	W	0
MR15-03_St104_Cast001_O18_#0432-W432	Niskin	2015	09	30	6:21	70	59.92	N	168	44.81	W	Chl-aMax
MR15-03_St104_Cast001_O18_#0433-W433	Niskin	2015	09	30	6:21	70	59.92	N	168	44.81	W	5
MR15-03_St104_Cast001_O18_#0434-W434	Niskin	2015	09	30	6:21	70	59.92	N	168	44.81	W	10
MR15-03_St104_Cast001_O18_#0435-W435	Niskin	2015	09	30	6:21	70	59.92	N	168	44.81	W	20
MR15-03_St104_Cast001_O18_#0436-W436	Niskin	2015	09	30	6:21	70	59.92	N	168	44.81	W	30
MR15-03_St104_Cast001_O18_#0437-W437	Niskin	2015	09	30	6:21	70	59.92	N	168	44.81	W	B-10
MR15-03_St104_Cast001_O18_#0438-W438	Niskin	2015	09	30	6:21	70	59.92	N	168	44.81	W	B-10
MR15-03_St105_Cast001_O18_#0439-W439	Bucket	2015	09	30	9:44	70	29.958	N	168	45.14	W	0
MR15-03_St105_Cast001_O18_#0440-W440	Niskin	2015	09	30	9:44	70	29.958	N	168	45.14	W	Chl-aMax
MR15-03_St105_Cast001_O18_#0441-W441	Niskin	2015	09	30	9:44	70	29.958	N	168	45.14	W	5
MR15-03_St105_Cast001_O18_#0442-W442	Niskin	2015	09	30	9:44	70	29.958	N	168	45.14	W	10
MR15-03_St105_Cast001_O18_#0443-W443	Niskin	2015	09	30	9:44	70	29.958	N	168	45.14	W	20
MR15-03_St105_Cast001_O18_#0444-W444	Niskin	2015	09	30	9:44	70	29.958	N	168	45.14	W	30
MR15-03_St105_Cast001_O18_#0445-W445	Niskin	2015	09	30	9:44	70	29.958	N	168	45.14	W	B-10
MR15-03_St105_Cast001_O18_#0446-W446	Niskin	2015	09	30	9:44	70	29.958	N	168	45.14	W	B-10
MR15-03_St106_Cast001_O18_#0447-W447	Bucket	2015	10	01	0:31	72	00.11	N	168	44.74	W	0
MR15-03_St106_Cast001_O18_#0448-W448	Niskin	2015	10	01	0:31	72	00.11	N	168	44.74	W	Chl-aMax
MR15-03_St106_Cast001_O18_#0449-W449	Niskin	2015	10	01	0:31	72	00.11	N	168	44.74	W	5
MR15-03_St106_Cast001_O18_#0450-W450	Niskin	2015	10	01	0:31	72	00.11	N	168	44.74	W	10
MR15-03_St106_Cast001_O18_#0451-W451	Niskin	2015	10	01	0:31	72	00.11	N	168	44.74	W	20
MR15-03_St106_Cast001_O18_#0452-W452	Niskin	2015	10	01	0:31	72	00.11	N	168	44.74	W	30

MR15-03_St106_Cast001_O18_#0453-W453	Niskin	2015	10	01	0:31	72	00.11	N	168	44.74	W	40
MR15-03_St106_Cast001_O18_#0454-W454	Niskin	2015	10	01	0:31	72	00.11	N	168	44.74	W	Not sampled
MR15-03_St106_Cast001_O18_#0455-W455	Niskin	2015	10	01	0:31	72	00.11	N	168	44.74	W	B-10
MR15-03_St106_Cast001_O18_#0456-W456	Niskin	2015	10	01	0:31	72	00.11	N	168	44.74	W	B-10
MR15-03_St107_Cast001_O18_#0457-W457	Bucket	2015	10	01	4:24	68	29.93	N	168	45.01	W	0
MR15-03_St107_Cast001_O18_#0458-W458	Niskin	2015	10	01	4:24	68	29.93	N	168	45.01	W	Chl-aMax
MR15-03_St107_Cast001_O18_#0459-W459	Niskin	2015	10	01	4:24	68	29.93	N	168	45.01	W	5
MR15-03_St107_Cast001_O18_#0460-W460	Niskin	2015	10	01	4:24	68	29.93	N	168	45.01	W	10
MR15-03_St107_Cast001_O18_#0461-W461	Niskin	2015	10	01	4:24	68	29.93	N	168	45.01	W	20
MR15-03_St107_Cast001_O18_#0462-W462	Niskin	2015	10	01	4:24	68	29.93	N	168	45.01	W	30
MR15-03_St107_Cast001_O18_#0463-W463	Niskin	2015	10	01	4:24	68	29.93	N	168	45.01	W	40
MR15-03_St107_Cast001_O18_#0464-W464	Niskin	2015	10	01	4:24	68	29.93	N	168	45.01	W	B-10
MR15-03_St107_Cast001_O18_#0465-W465	Niskin	2015	10	01	4:24	68	29.93	N	168	45.01	W	B-10
MR15-03_St108_Cast001_O18_#0466-W466	Bucket	2015	10	03	9:48	67	00.02	N	168	44.89	W	0
MR15-03_St108_Cast001_O18_#0467-W467	Niskin	2015	10	03	9:48	67	00.02	N	168	44.89	W	Chl-aMax
MR15-03_St108_Cast001_O18_#0468-W468	Niskin	2015	10	03	9:48	67	00.02	N	168	44.89	W	5
MR15-03_St108_Cast001_O18_#0469-W469	Niskin	2015	10	03	9:48	67	00.02	N	168	44.89	W	10
MR15-03_St108_Cast001_O18_#0470-W470	Niskin	2015	10	03	9:48	67	00.02	N	168	44.89	W	20
MR15-03_St108_Cast001_O18_#0471-W471	Niskin	2015	10	03	9:48	67	00.02	N	168	44.89	W	30
MR15-03_St108_Cast001_O18_#0472-W472	Niskin	2015	10	03	9:48	67	00.02	N	168	44.89	W	B-10
MR15-03_St108_Cast001_O18_#0473-W473	Niskin	2015	10	03	9:48	67	00.02	N	168	44.89	W	B-10
MR15-03_St109_Cast001_O18_#0474-W474	Bucket	2015	10	03	16:26	66	00.12	N	168	45.04	W	0
MR15-03_St109_Cast001_O18_#0475-W475	Niskin	2015	10	03	16:26	66	00.12	N	168	45.04	W	Chl-aMax
MR15-03_St109_Cast001_O18_#0476-W476	Niskin	2015	10	03	16:26	66	00.12	N	168	45.04	W	5
MR15-03_St109_Cast001_O18_#0477-W477	Niskin	2015	10	03	16:26	66	00.12	N	168	45.04	W	10
MR15-03_St109_Cast001_O18_#0478-W478	Niskin	2015	10	03	16:26	66	00.12	N	168	45.04	W	20
MR15-03_St109_Cast001_O18_#0479-W479	Niskin	2015	10	03	16:26	66	00.12	N	168	45.04	W	30
MR15-03_St109_Cast001_O18_#0480-W480	Niskin	2015	10	03	16:26	66	00.12	N	168	45.04	W	40
MR15-03_St109_Cast001_O18_#0481-W481	Niskin	2015	10	03	16:26	66	00.12	N	168	45.04	W	B-10
MR15-03_St109_Cast001_O18_#0482-W482	Niskin	2015	10	03	16:26	66	00.12	N	168	45.04	W	B-10

4.6. Underway surface water monitoring

(1) Personnel

Shigeto Nishino	JAMSTEC	-PI
Hiroshi Uchida	JAMSTEC	
Hironori Sato	WMJ	
Haruka Tamada	MWJ	
Yoshiki Kido	MWJ	
Shinichiro Yokogawa	MWJ	

(2) Objective

Our purpose is to obtain temperature, salinity, dissolved oxygen, and fluorescence data continuously in near-sea surface water.

(3) Parameters

Temperature (surface water)
Salinity (surface water)
Dissolved oxygen (surface water)
Fluorescence (surface water)
Turbidity (surface water)
Nitrate (surface water)

(4) Instruments and Methods

The Continuous Sea Surface Water Monitoring System (Marine Works Japan Co. Ltd.) has five sensors and automatically measures temperature, salinity, dissolved oxygen and fluorescence in near-sea surface water every one minute. This system is located in the “*sea surface monitoring laboratory*” and connected to shipboard LAN-system. Measured data, time, and location of the ship were stored in a data management PC. The near-surface water was continuously pumped up to the laboratory from about 4.5 m water depth and flowed into the system through a vinyl-chloride pipe. The flow rate of the surface seawater was adjusted to be 10 dm³ min⁻¹.

A chemical-free nitrate sensor was also used with the Continuous Sea Surface Monitoring System. The nitrate sensor was attached using a flow cell next to the thermo-salinograph.

a. Instruments

Software

Seamoni-kun Ver.1.50

Sensors

Specifications of the each sensor in this system are listed below.

Temperature and Conductivity sensor

Model: SBE-45, SEA-BIRD ELECTRONICS, INC.

Serial number: 4552788-0264

Measurement range: Temperature -5 to +35 °C

Conductivity 0 to 7 S m⁻¹

Initial accuracy: Temperature 0.002 °C

Conductivity 0.0003 S m⁻¹

Typical stability (per month): Temperature 0.0002 °C

Conductivity 0.0003 S m⁻¹

Resolution: Temperatures 0.0001 °C

Conductivity 0.00001 S m⁻¹

Bottom of ship thermometer

Model: SBE 38, SEA-BIRD ELECTRONICS, INC.

Serial number: 3852788-0457

Measurement range: -5 to +35 °C

Initial accuracy: ±0.001 °C

Typical stability (per 6 month): 0.001 °C

Resolution: 0.00025 °C

Dissolved oxygen sensor

Model: OPTODE 3835, AANDERAA Instruments.

Serial number: 1915

Measuring range: 0 - 500 µmol dm⁻³

Resolution: < 1 µmol dm⁻³

Accuracy: < 8 µmol dm⁻³ or 5 % whichever is greater

Settling time: < 25 s

Dissolved oxygen sensor

Model: RINKO II, JFE ADVANTECH CO. LTD.
 Serial number: 13
 Measuring range: 0 - 540 $\mu\text{mol dm}^{-3}$
 Resolution: < 0.1 $\mu\text{mol dm}^{-3}$
 or 0.1 % of reading whichever is greater
 Accuracy: < 1 $\mu\text{mol dm}^{-3}$
 or 5 % of reading whichever is greater

Fluorescence & Turbidity sensor

Model: C3, TURNER DESIGNS
 Serial number: 2300384

Nitrate sensor

Model: Deep SUNA, SATLANTIC, LP.
 Serial number: 0385

(5) Observation log

Periods of measurement, maintenance, and problems during MR15-03 are listed in Table 4.6-1.

Table 4.6-1: Events list of the Sea surface water monitoring during MR15-03

System Date [UTC]	System Time [UTC]	Events	Remarks
2015/08/31	10:47	All the measurements started and data was available.	Leg1 start
2015/09/05	03:30	All the measurements stopped.	Filter , C3 & SUNA Cleaning
2015/09/05	22:24	All the measurements started.	Logging restart
2015/09/14	15:24	All the measurements stopped.	Filter , C3 & SUNA Cleaning
2015/09/14	16:43	All the measurements started.	Logging restart
2015/09/19	00:16	All the measurements stopped.	Filter , C3 & SUNA Cleaning
2015/09/19	02:42	All the measurements started.	Logging restart
2015/10/06	00:31	All the measurements stopped.	Leg1 end

2015/10/09	23:15	All the measurements started.	Leg2 start
2015/10/19	05:30	All the measurements stopped.	Leg2 end

We took the surface water samples once a day to compare sensor data with bottle data of salinity, dissolved oxygen, chlorophyll *a* and nitrate. The results are shown in Fig. 4.6 -2. All the salinity samples were analyzed by the Guideline 8400B “AUTOSAL” (see 3.7), and dissolve oxygen samples were analyzed by Winkler method (see 4.1), chlorophyll *a* were analyzed by 10-AU (see 4.11), and nitrate were analyzed by QuAAtro (see 4.2).

(a)

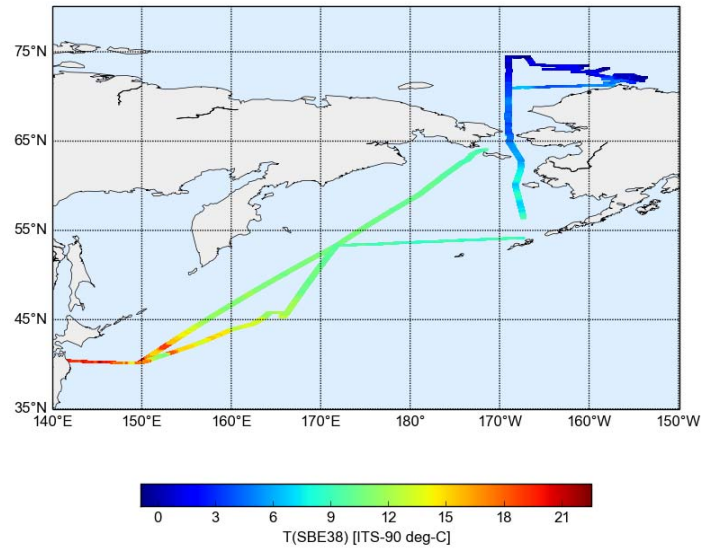

(b)

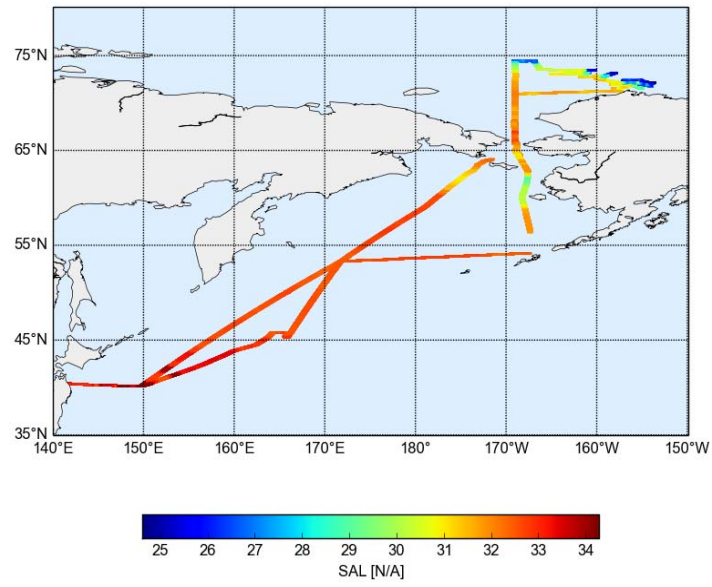

(c)

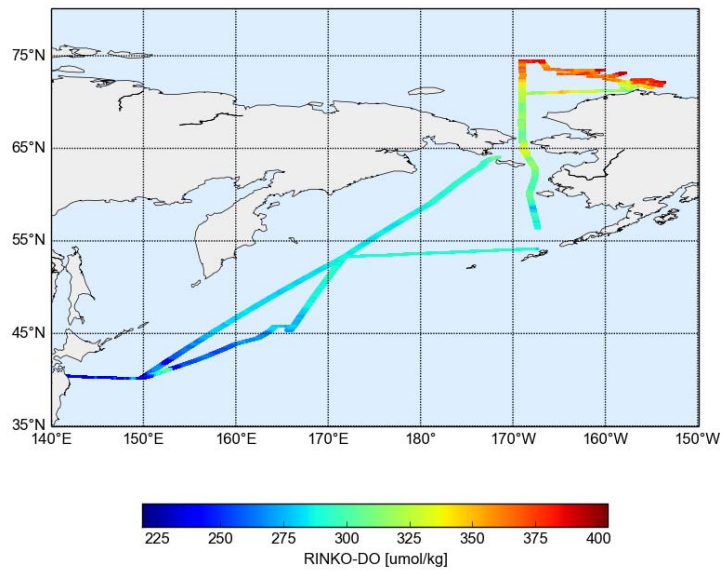

(d)

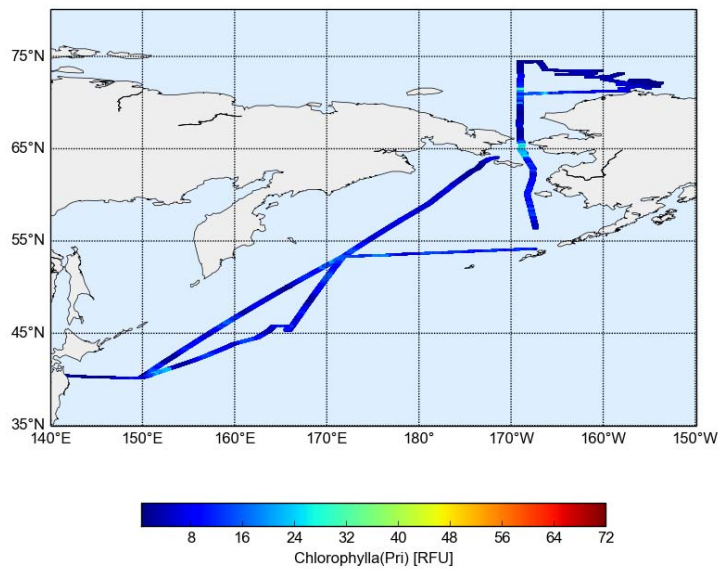

Figure 4.6-1: Spatial and temporal distribution of (a) temperature, (b) salinity, (c) dissolved oxygen, and (d) fluorescence in MR15-03 cruise.

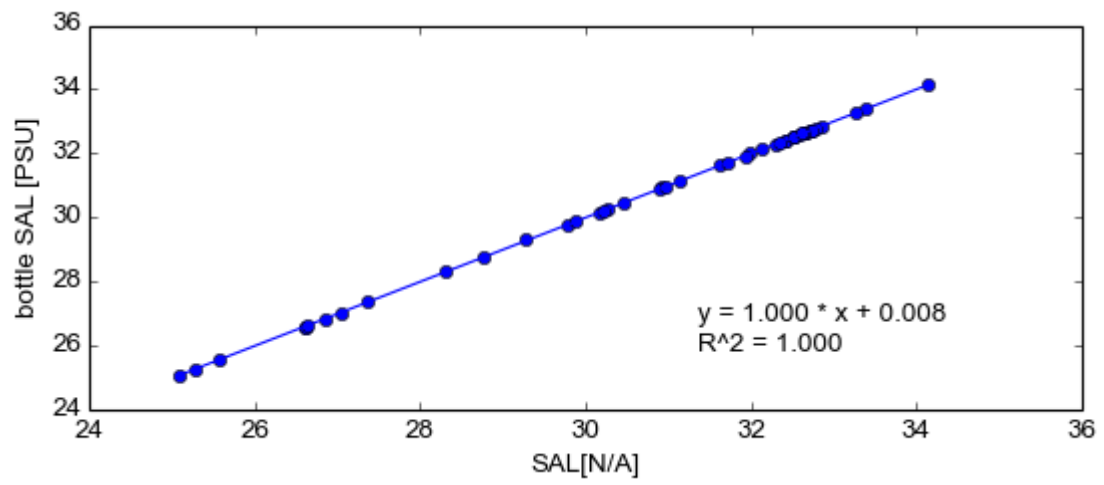

Figure 4.6-2-1: Correlation of salinity between sensor data and bottle data.

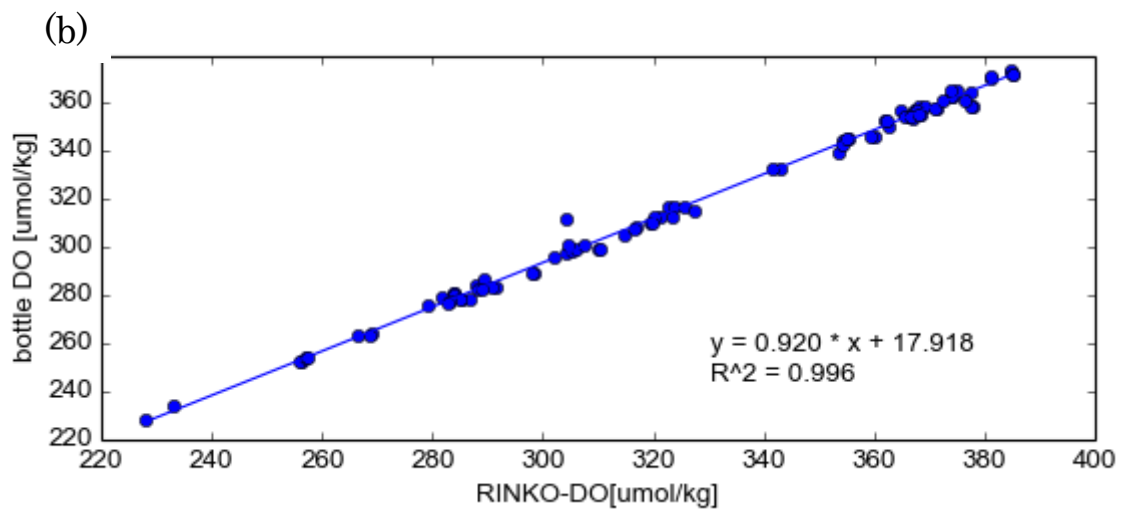
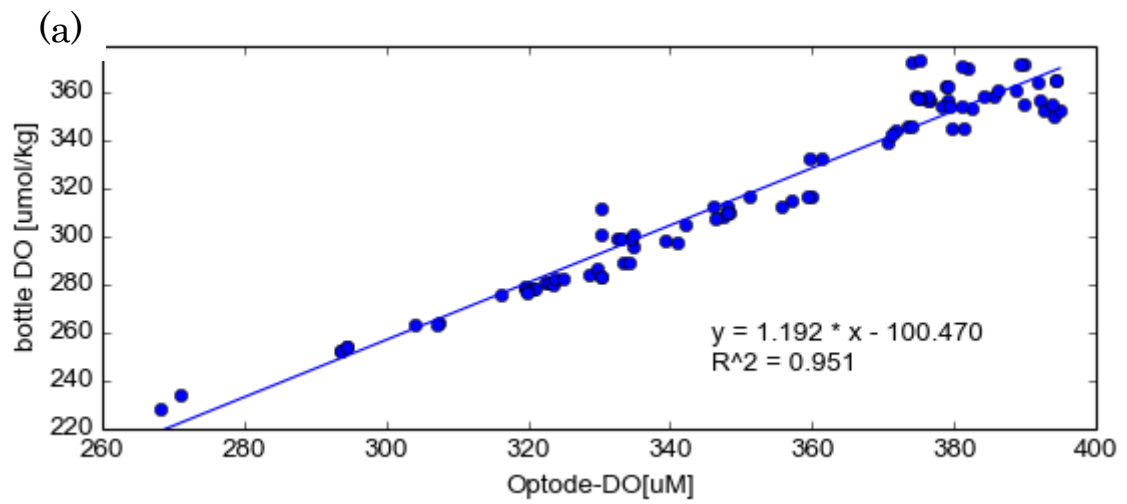

Figure 4.6-2-2: Correlation of dissolved oxygen between sensor data and bottle data.
 (a: OPTODE, b: RINKO)

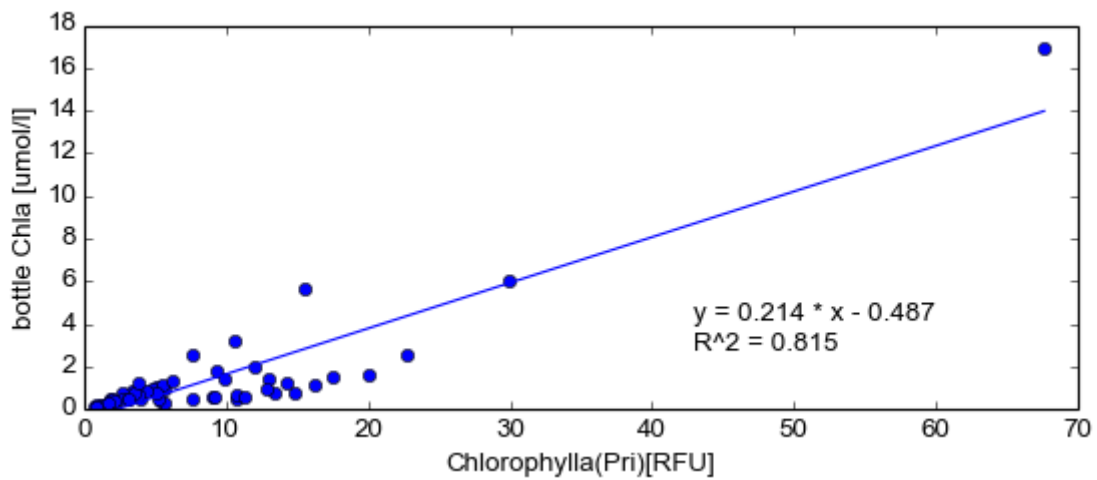

Figure 4.6-2-3: Correlation of fluorescence between sensor data and bottle data.

(6) Data archives

These data obtained in this cruise will be submitted to the Data Management Group of JAMSTEC, and will be opened to the public via “Data Research System for Whole Cruise Information in JAMSTEC (DARWIN)” in JAMSTEC web site.

<<http://www.godac.jamstec.go.jp/darwin/e>>

4.7. Dissolved greenhouse gases

4.7.1. Continuous measurement of surface water for $p\text{CO}_2/p\text{CH}_4$ by CRDS

(1) Personnel

Masao Ishii	Meteorological Research Institute / JMA: Principal Investigator
Shuji Aoki	Tohoku University
Sohiko Kameyama	Hokkaido University
Hisayuki Yoshikawa-Inoue	Hokkaido University
Daisuke Sasano	Meteorological Research Institute / JMA
Naohiro Kosugi	Meteorological Research Institute / JMA
Hiroshi Uchida	JAMSTEC

(2) Objective

The oceans have strong interactions with the atmosphere and are the major sinks for the increasing CO_2 . Although it is believed that the Arctic Ocean is playing an important role for the variations of greenhouse gases in the atmosphere, their spatial and temporal variations in the Arctic Ocean is not well known. Furthermore, sea ice in the Arctic Ocean has been decreasing in summer, leading to change the air-sea interaction and biological activity due to increasing the area of open sea, and possibly leading to affect the global carbon cycle.

Recently, a new CO_2 analyzer WS-CRDS (Picarro G2301) was developed on the basis of Cavity Ring-Down Spectroscopy. The advantage of this analyzer is a high precision and stability. In addition, the analyzer can simultaneously measure other trace gases such as CH_4 . In this study, we challenge to apply WS-CRDS to the underway measurements of $p\text{CO}_2$ and $p\text{CH}_4$ in the atmosphere and in surface seawater to clarify the distributions of $p\text{CO}_2$ and $p\text{CH}_4$ and their controlling mechanisms in the Arctic Ocean.

(3) Parameters

Partial pressure of CO_2 ($p\text{CO}_2$) and CH_4 ($p\text{CH}_4$) in the atmosphere and in near-surface seawater

(4) Instruments and Methods

We made simultaneous measurements of the CO_2 and CH_4 concentrations in the dry air equilibrated with the great excess of surface seawater during the whole cruise using an automated measuring system (Nippon ANS Co.). Seawater was taken continuously from

the seachest located ca.4.5 m below the sea level and introduced into the MRI-shower-type equilibrator. Wavelength-scanned cavity ring-down spectrometer (WS-CRDS, Picarro, G2301) was used as a detector. We used three standard gases with known CO₂ and CH₄ mixing ratios once a day. Corrections for the temperature-rise from the seachest to the equilibrator are also to be made. Partial pressure of CO₂ and CH₄ will be calculated from the concentration of CO₂ and CH₄ by taking the water vapor pressure and the atmospheric pressure into account.

(5) Observation log

The shipboard continuous measurements were conducted from 2015/8/28 (UTC) to 2015/10/6 (UTC).

(6) Calibration

3 sets of standard gas were used for calibration. Each standard gas was measured once a day to check stability and precision of output. Concentration of standard gas ranged 206.34 – 489.28 ppmv for CO₂ and 1593-2117 ppbv for CH₄.

(7) Data archives

These data obtained in this cruise will be submitted to the Data Management Group of JAMSTEC, and will be opened to the public via “Data Research System for Whole Cruise Information in JAMSTEC (DARWIN)” in JAMSTEC web site.

4.7.2. Discrete bottle sampling for CH₄, N₂O and their isotopocules

(1) Personnel

Masao Ishii	Meteorological Research Institute / JMA	-PI
Sakae Toyoda	Interdisciplinary Graduate School of Science and Engineering Tokyo Institute of Technology	
Kushi Kudo	Interdisciplinary Graduate School of Science and Engineering Tokyo Institute of Technology	
Takahito Kakimoto	Interdisciplinary Graduate School of Science and Engineering Tokyo Institute of Technology	
Keita Yamada	Interdisciplinary Graduate School of Science and Engineering Tokyo Institute of Technology	
Naohiro Yoshida	Interdisciplinary Graduate School of Science and Engineering Tokyo Institute of Technology	

(2) Objective

Methane (CH₄) and nitrous oxide (N₂O) are increasing greenhouse gases, and N₂O is also the most important ozone-depleting gas in the stratosphere (IPCC, 2013; Ravishankara et al., 2009). Although the increase of CH₄ and N₂O is mainly caused by anthropogenic emissions such as agriculture and fossil fuel combustion, they are biogenically produced or consumed, and emitted from various sources including oceans. Several studies have reported over-saturation of CH₄ and N₂O with respect to atmospheric equilibrium in the surface water of several regions in the Arctic Ocean (Kitidis et al., 2010 and references therein). In this study, we aimed (1) to reveal the horizontal and vertical distributions of CH₄ and N₂O in the Bering Strait and the Chukchi Sea, (2) to analyze their production or consumption processes based on relative abundance of isotopocules, isotope-substituted molecules such as ¹³CH₄, CH₃D, ¹⁵NNO, N¹⁵NO, and NN¹⁸O, and (3) to examine year-to-year variation by comparing the results obtained with samples collected in previous cruises (MR12-E03, MR13-06, and MR14-05) in the Arctic Ocean.

(3) Parameters

Concentration, stable carbon and hydrogen isotope ratios of dissolved CH₄

Concentration, stable nitrogen and oxygen isotope ratios including ¹⁵N-site preference (SP) in dissolved N₂O

(4) Instruments and Methods

Seawater samples were collected using CTD-CAROUSEL system equipped with 12-L Niskin bottles. Surface water were also sampled with a bucket. Sampling locations and depth profile are listed in Table 4.7.2-1. Each sample was subsampled into 30, 125, 600, and 225 (duplicate) ml glass vials to avoid air contamination for analysis of CH₄ concentration, stable carbon and hydrogen isotope ratio of CH₄ and N₂O isotope ratios, respectively. These seawater samples were sterilized by adding saturated mercuric chloride (HgCl₂) solution to avoid excess CH₄ emission from microbe, and were sealed with rubber stoppers and aluminum caps. They will be stored in a dark and cool place until measurements.

Concentration of dissolved CH₄ will be measured with a gas chromatograph equipped

with a flame ionization detector (GC-FID). Stable carbon isotope ratio will be measured with gas chromatography-combustion-isotope ratio mass spectrometry (GC-C-IRMS) (Tsunogai et al., 2000). Stable hydrogen isotope ratio will be measured with gas chromatography-high-temperature conversion-isotope ratio mass spectrometry (GC-TC-IRMS) (Yamada et al., 2003). Each analytical system is equipped with a purge and trap unit, and CH₄ is further concentrated in a cryogenic trap in the case of isotopic measurement. Precisions of repeated analyses of CH₄ concentration, and carbon and hydrogen isotope ratio are estimated to be better than 5%, 0.3‰ and 3‰, respectively.

Dissolved N₂O concentrations and its isotopic compositions will be measured similarly by mass spectrometry, although the extracted and purified N₂O is directly introduced into the mass spectrometry (GC-IRMS) which was modified for site-specific ¹⁵N analysis (Yamagishi et al., 2007)

(5) Station list or Observation log

Table 4.7.2-1. Sample list

CH ₄ conc., δ ¹³ C _{CH4}				N ₂ O conc., δ ¹⁵ N _{N2O} , δ ¹⁸ O _{N2O} , SP				CH ₃ D			
30 mL, 100 mL vial				200 mL vial *2				500 mL glass bottle			
#	Station	Bottle	Depth [dbar]	#	Station	Bottle	Depth [dbar]	#	Station	Bottle	Depth [dbar]
1	1	15	5	1	1	15	5	1	1	15	5
2		14	10	2		13	20	2		13	20
3		13	20	3		12	30	3	6	15	5
4		12	30	4		11	40	4		13	20
5		11	40	5	6	15	5	5	13	12	5
6	6	15	5	6		13	20	6		10	20
7		14	10	7		12	30	7		7	50
8		13	20	8		11	40	8	28	36	5
9		12	30	9	13	12	5	9		34	20
10		11	40	10		10	20	10		31	50
11	13	12	5	11		7	50	11	29	36	5
12		11	10	12	28	36	5	12		34	20
13		10	20	13		34	20	13		31	50
14		9	30	14		31	50	14		30	100
15		8	40	15	29	36	5	15	53	36	5
16		7	50	16		34	20	16		34	20
17		2	B-10	17		31	50	17		31	50
18	28	36	5	18		30	100	18		30	100
19		34	20	19	53	36	5	19		28	200
20		31	50	20		31	50	20	54	36	5
21	29	36	5	21		30	100	21		34	20
22		34	20	22		28	200	22		32	50
23		31	50	23		7	500	23	85	36	5
24		30	100	24		4	1000	24		34	20

25	53	36	5	25		3	1500	25		32	50
26		35	10	26	54	36	5	26		31	100
27		34	20	27		34	20	27		29	200
28		31	50	28		32	50	28	95	36	5
29		30	100	29		31	100	29		34	20
30		28	200	30		30	150	30		32	50
31		7	500	31		29	200	31	100	36	5
32		5	0	32	85	36	5	32		34	20
33		4	1000	33		32	50	33		32	50
34		3	1500	34		31	100	34	102	36	5
35	54	36	5	35		29	200	35		34	20
36		35	10	36		27	B-10	36		31	50
37		34	20	37	95	36	5	37	104	36	5
38		33	30	38		34	20	38		34	20
39		32	50	39		32	50	39		27	B-10
40		31	100	40		27	B-10	40	108	17	5
41		30	150	41	100	36	5	41		17	5
42		29	200	42		34	20	42		15	20
43	85	36	5	43		32	50	43		15	20
44		35	10	44		31	100	44		14	30
45		34	20	45		30	150	45		14	30
46		33	30	46		27	B-10	46	109	36	5
47		19	40	47	102	36	5	47		36	5
48		32	50	48		34	20	48		34	20
49		31	100	49		33	30	49		34	20
50		30	150	50		32	40	50		32	40
51		29	200	51		31	50				
52		28	300	52	104	36	5				
53		27	B-10	53		34	20				
54	95	36	5	54		27	B-10				
55		35	10	55	108	17	5				
56		34	20	56		17	5				
57		33	30	57		15	20				
58		19	40	58		15	20				
59		32	50	59		14	30				
60		27	B-10	60		14	30				
61	100	36	5	61	109	36	5				
62		35	10	62		34	20				
63		34	20	63		32	40				
64		33	30								
65		28	40								
66		32	50								

67		31	100
68		30	150
69		27	B-10
70	102	36	5
71		36	5
72		35	10
73		35	10
74		34	20
75		34	20
76		33	30
77		33	30
78		32	40
79		32	40
80		31	50
81		31	50
82	104	36	5
83		35	10
84		34	20
85		33	30
86		27	B-10
87	108	17	5
88		17	5
89		16	10
90		16	10
91		15	20
92		15	20
93		14	30
94		14	30
95	109	36	5
96		36	5
97		35	10
98		35	10
99		34	20
100		34	20
101		33	30
102		32	40

(6) Expected results

In our previous observations, concentrations of dissolved CH₄ and N₂O ranged from 0.5 to 48.5 nmol/kg and from 9.3 to 49.0 nmol/kg, respectively, and most of the samples showed oversaturation of these gases with respect to the atmosphere. The highest values were

observed near the seafloor at a shallow station in continental shelf in 2013. Results obtained from the present cruise will clarify the variability of distribution and production/consumption processes of CH₄ and N₂O.

(7) Data archives

These data obtained in this cruise will be submitted to the Data Management Group of JAMSTEC, and will be opened to the public via “Data Research System for Whole Cruise Information in JAMSTEC (DARWIN)” in JAMSTEC web site.

After the measurements and quality check, concentration and isotopic data will be submitted to JAMSTEC.

(8) References

- IPCC (2013), *Climate Change 2013: The Physical Science Basis. Contribution of Working Group I to the Fifth Assessment Report of the Intergovernmental Panel on Climate Change* 1535 pp., Cambridge University Press, Cambridge, United Kingdom and New York, NY, USA
- Kitidis, V., R. C. Upstill-Goddard, and L. G. Anderson (2010), Methane and nitrous oxide in surface water along the North-West Passage, Arctic Ocean, *Marine Chemistry*, 121(1–4), 80-86, doi:10.1016/j.marchem.2010.03.006.
- Ravishankara, A. R., J. S. Daniel, and R. W. Portmann (2009), Nitrous oxide (N₂O): The dominant ozone-depleting substance emitted in the 21st century, *Science*, 326, 123, doi:10.1126/science.1176985.
- Bange, H. W., U. H. Bartell, S. Rapsomanikis, and M. O. Andreae: Methane in the Baltic and the north seas and a reassessment of the marine emissions of methane, *Global Biogeochem. Cycles*, 8, 465–480, 1994.
- Tsunogai, U., Yoshida, N., Ishibashi, J., Gamo, T., 2000. Carbon isotopic distribution of methane in deep-sea hydrothermal plume, Myojin Knoll caldera, Izu–Bonin arc: implications for microbial methane oxidation in the oceans and applications to heat flux estimation. *Geochim. Cosmochim. Acta* 64, 2439–2452.
- Yamada, K., Ozaki, Y., Nakagawa, F., Tanaka, M., Yoshida, N., 2003. An improved method for measurement of the hydrogen isotope ratio of atmospheric methane and its application to a Japanese urban atmosphere. *Atmos. Environ.* 37, 1975–1982.
- Yamagishi, H., M. B. Westley, B. N. Popp, S. Toyoda, N. Yoshida, S. Watanabe, K. Koba, and Y. Yamanaka (2007), Role of nitrification and denitrification on the nitrous oxide cycle in the eastern tropical North Pacific and Gulf of California, *J. Geophys. Res.: Biogeosci.*, 112(G2), G02015, doi:10.1029/2005JG000227.

4.7.3. Onboard measurements for CO₂ and CH₄ and their isotopomers

(1) Personnel

Nobuyoshi Yamashita	National Institute of Advanced Industrial Science and Technology -PI
Kosuke Noborio	Meiji University
Yuki Ito	Meiji University
Shujiro Komiya	Meiji University

(2) Objective

The exchange of methane (CH₄) and carbon dioxide (CO₂) at the air-sea interface is a major contributor to the global carbon cycle. Previous studies have theoretically estimated their exchange rates by the bulk method, i.e. a gas concentration gradient between in the air and in the seawater multiplied by a gas transfer coefficient usually as a function of wind speed. Recent advancement in computers and microelectronics enabled devices to measure CO₂ concentration and three-dimensional wind speed with the time scan rate of >10 Hz. Using those instruments a standard micrometeorological procedure, e.g., eddy covariance (EC), was established to directly measure CO₂ flux in a real time manner on the ground or above the tree canopy. Kondo and Tsukamoto (2007) applied the EC procedure to directly measure CO₂ flux at the air-sea interface with the aid of a 3-axis inclinometer and accelerometer boarding on a ship. They reported that the CO₂ flux measured with the micrometeorological method was as large as 20 times that estimated with the conventional bulk method. Not much research has been reported on the direct measurement of CH₄ flux at the air-sea interface because of few high-speed instruments available for measuring CH₄ concentration until a few years back. Our research group has developed another micrometeorological procedure, e.g., relaxed eddy accumulation (REA), and successfully applied to agricultural fields. Although the REA does not require a high-speed instrument to measure gas concentration, results are comparable to those with the EC. We're interested to apply our REA to the air-sea interface. The objectives of our research were to collect CTD sampling at several station for measuring dissolved CH₄ and CO₂ and their isotopomers to compare with CH₄ and CO₂ flux at the air-sea interface along the meridian in the Arctic Ocean with MR-15-03 in 2015 by REA and the bulk method.

(3) Parameters

Dissolved CO₂, CH₄, and their isotope

(4) Instruments and Methods

The dissolved concentration of CH₄ and CO₂ and $\delta^{13}\text{C}$ of CH₄ and CO₂ in the equilibrated air with seawater, collected with CTD, was alternatively measured every 3 min with a CO₂/CH₄/ $\delta^{13}\text{C}$ laser gas analyzer (G2201-i, Picarro Inc., Santa Clara, CA) installed in Environmental Research Lab. 0.5L with plastic container and 0.06L with syringe of seawater was collected. The water collected was transferred into a dissolved gas equilibrators made of 0.25 mm thick-silicon tubings in a 0.5 L plastic container. Syringe samples were added N₂ gas and shaken for 3min. Dissolved CH₄ and CO₂ and their $\delta^{13}\text{C}$ values of plastic container were measured with the laser gas analyzer after at least 12 h

equilibration and of syringe were measured right after shaken.

(5) Observation log

Table 4.7.3-1: List of station/cast for dissolved concentration of CH₄ and CO₂ and $\delta^{13}\text{C}$ of CH₄ and CO₂ in the equilibrated air with seawater by syringe

On board ID	Sampling Method	Date Collected					Latitude			Longitude			Depth [m]	Locality	Remarks
		YYYY	MM	DD	hh:mm	UTC/JST	Deg.	Min.	N/S	Deg.	Min.	E/W			
MR1503-WB01	Bucket	2015	9	6	6:37	UTC	65	45.696	N	168	45.198	W	0.0	Sta. 001	
MR1503-WB02	Bucket	2015	9	7	1:26	UTC	67	59.91	N	168	46.644	W	0.0	Sta. 006	Cast 2
MR1503-WB03	Bucket	2015	9	9	7:08	UTC	71	14.898	N	157	9.666	W	0.0	Sta. 016	
MR1503-WB04	Bucket	2015	9	12	0:49	UTC	71	49.512	N	155	50.766	W	0.0	Sta. 025	
MR1503-WB05	Bucket	2015	9	12	3:17	UTC	71	48.264	N	155	22.716	W	0.0	Sta. 026	
MR1503-WB06	Bucket	2015	9	12	6:33	UTC	71	39.96	N	155	1.416	W	0.0	Sta. 027	
MR1503-WB07	Bucket	2015	9	14	8:52	UTC	72	1.32	N	155	53.568	W	0.0	Sta. 035	
MR1503-WB08	Bucket	2015	9	14	4:14	UTC	72	26.19	N	156	35.454	W	0.0	Sta. 040	
MR1503-WB09	Bucket	2015	9	14	4:32	UTC	72	20.202	N	156	10.518	W	0.0	Sta. 052	
MR1503-WB10	Bucket	2015	9	15	7:57	UTC	72	20.37	N	155	23.106	W	0.0	Sta. 053	Cast 8
MR1503-WB11	Bucket	2015	9	15	19:57	UTC	72	21.324	N	155	23.562	W	0.0	Sta. 053	Cast 12
MR1503-WB12	Bucket	2015	9	16	8:13	UTC	72	20.508	N	155	23.502	W	0.0	Sta. 053	Cast 16
MR1503-WB13	Bucket	2015	9	17	7:56	UTC	72	16.302	N	155	57.294	W	0.0	Sta. 056	Cast 4
MR1503-WB14	Bucket	2015	9	17	2:42	UTC	72	16.95	N	155	59.37	W	0.0	Sta. 056	Cast 10
MR1503-WB15	Bucket	2015	9	18	7:55	UTC	72	16.77	N	155	58.536	W	0.0	Sta. 056	Cast 12
MR1503-WB16	Bucket	2015	9	20	11:03	UTC	72	11.154	N	153	33.498	W	0.0	Sta. 060	
MR1503-WB17	Bucket	2015	9	21	6:25	UTC	72	22.254	N	155	31.128	W	0.0	Sta. 063	
MR1503-WB18	Bucket	2015	9	21	9:52	UTC	72	15.882	N	155	57.948	W	0.0	Sta. 064	
MR1503-WB19	Bucket	2015	9	22	13:07	UTC	72	11.67	N	156	15.498	W	0.0	Sta. 065	
MR1503-WB20	Bucket	2015	9	23	14:27	UTC	72	34.878	N	159	41.4	W	0.0	Sta. 072	
MR1503-WB21	Bucket	2015	9	23	5:47	UTC	72	53.238	N	158	48.042	W	0.0	Sta. 077	
MR1503-WB22	Bucket	2015	9	26	4:29	UTC	73	3.48	N	164	36.12	W	0.0	Sta. 084	
MR1503-WNS1	Niskin	2015	9	6	6:37	UTC	65	45.696	N	168	45.198	W	5.4	Sta. 001	
MR1503-WNS2	Niskin	2015	9	6	6:37	UTC	65	45.696	N	168	45.198	W	10.2	Sta. 001	
MR1503-WNS3	Niskin	2015	9	6	6:37	UTC	65	45.696	N	168	45.198	W	20.2	Sta. 001	
MR1503-WNS4	Niskin	2015	9	6	6:37	UTC	65	45.696	N	168	45.198	W	30.3	Sta. 001	
MR1503-WNS5	Niskin	2015	9	6	6:37	UTC	65	45.696	N	168	45.198	W	40.0	Sta. 001	
MR1503-WNS6	Niskin	2015	9	7	1:26	UTC	67	59.91	N	168	46.644	W	5.3	Sta. 006	
MR1503-WNS7	Niskin	2015	9	7	1:26	UTC	67	59.91	N	168	46.644	W	9.9	Sta. 006	
MR1503-WNS8	Niskin	2015	9	7	1:26	UTC	67	59.91	N	168	46.644	W	20.0	Sta. 006	
MR1503-WNS9	Niskin	2015	9	7	1:26	UTC	67	59.91	N	168	46.644	W	30.0	Sta. 006	
MR1503-WNS10	Niskin	2015	9	7	1:26	UTC	67	59.91	N	168	46.644	W	39.6	Sta. 006	
MR1503-WNS11	Niskin	2015	9	9	7:08	UTC	71	14.898	N	157	9.666	W	5.1	Sta. 016	
MR1503-WNS12	Niskin	2015	9	9	7:08	UTC	71	14.898	N	157	9.666	W	10.2	Sta. 016	

MR1503-WNS13	Niskin	2015	9	9	7:08	UTC	71	14.898	N	157	9.666	W	20.0	Sta. 016	
MR1503-WNS14	Niskin	2015	9	9	7:08	UTC	71	14.898	N	157	9.666	W	30.2	Sta. 016	
MR1503-WNS15	Niskin	2015	9	12	0:49	UTC	71	49.512	N	155	50.766	W	5.9	Sta. 025	
MR1503-WNS16	Niskin	2015	9	12	0:49	UTC	71	49.512	N	155	50.766	W	5.9	Sta. 025	
MR1503-WNS17	Niskin	2015	9	12	0:49	UTC	71	49.512	N	155	50.766	W	5.9	Sta. 025	
MR1503-WNS18	Niskin	2015	9	12	6:33	UTC	71	39.96	N	155	1.416	W	5.3	Sta. 027	
MR1503-WNS19	Niskin	2015	9	12	6:33	UTC	71	39.96	N	155	1.416	W	5.3	Sta. 027	
MR1503-WNS20	Niskin	2015	9	12	6:33	UTC	71	39.96	N	155	1.416	W	5.3	Sta. 027	
MR1503-WNS21	Niskin	2015	9	12	6:33	UTC	71	39.96	N	155	1.416	W	5.3	Sta. 027	
MR1503-WNS22	Niskin	2015	9	12	6:33	UTC	71	39.96	N	155	1.416	W	5.3	Sta. 027	
MR1503-WNS23	Niskin	2015	9	15	4:14	UTC	72	26.19	N	156	35.454	W	799.9	Sta. 040	
MR1503-WNS24	Niskin	2015	9	15	4:14	UTC	72	26.19	N	156	35.454	W	600.0	Sta. 040	
MR1503-WNS25	Niskin	2015	9	15	4:14	UTC	72	26.19	N	156	35.454	W	5.6	Sta. 040	
MR1503-WNS26	Niskin	2015	9	15	4:14	UTC	72	26.19	N	156	35.454	W	5.6	Sta. 040	
MR1503-WNS27	Niskin	2015	9	15	4:14	UTC	72	26.19	N	156	35.454	W	50.1	Sta. 040	
MR1503-WNS28	Niskin	2015	9	15	4:14	UTC	72	26.19	N	156	35.454	W	50.1	Sta. 040	
MR1503-WNS29	Niskin	2015	9	15	4:14	UTC	72	26.19	N	156	35.454	W	199.5	Sta. 040	
MR1503-WNS30	Niskin	2015	9	15	4:14	UTC	72	26.19	N	156	35.454	W	399.7	Sta. 040	
MR1503-WNS31	Niskin	2015	9	17	7:57	UTC	72	20.37	N	155	23.106	W	5.3	Sta. 053	cast 8
MR1503-WNS32	Niskin	2015	9	17	7:57	UTC	72	20.37	N	155	23.106	W	10.1	Sta. 053	
MR1503-WNS33	Niskin	2015	9	17	7:57	UTC	72	20.37	N	155	23.106	W	20.1	Sta. 053	
MR1503-WNS34	Niskin	2015	9	17	7:57	UTC	72	20.37	N	155	23.106	W	30.1	Sta. 053	
MR1503-WNS35	Niskin	2015	9	17	7:57	UTC	72	20.37	N	155	23.106	W	40.0	Sta. 053	
MR1503-WNS36	Niskin	2015	9	17	7:57	UTC	72	20.37	N	155	23.106	W	50.1	Sta. 053	
MR1503-WNS37	Niskin	2015	9	17	7:57	UTC	72	20.37	N	155	23.106	W	100.0	Sta. 053	
MR1503-WNS38	Niskin	2015	9	17	7:57	UTC	72	20.37	N	155	23.106	W	199.9	Sta. 053	
MR1503-WNS39	Niskin	2015	9	17	19:57	UTC	72	21.324	N	155	23.562	W	4.8	Sta. 053	cast 12
MR1503-WNS40	Niskin	2015	9	17	19:57	UTC	72	21.324	N	155	23.562	W	9.7	Sta. 053	
MR1503-WNS41	Niskin	2015	9	17	19:57	UTC	72	21.324	N	155	23.562	W	19.6	Sta. 053	
MR1503-WNS42	Niskin	2015	9	17	19:57	UTC	72	21.324	N	155	23.562	W	29.6	Sta. 053	
MR1503-WNS43	Niskin	2015	9	17	19:57	UTC	72	21.324	N	155	23.562	W	39.7	Sta. 053	
MR1503-WNS44	Niskin	2015	9	17	19:57	UTC	72	21.324	N	155	23.562	W	50.1	Sta. 053	
MR1503-WNS45	Niskin	2015	9	17	19:57	UTC	72	21.324	N	155	23.562	W	100.2	Sta. 053	
MR1503-WNS46	Niskin	2015	9	17	19:57	UTC	72	21.324	N	155	23.562	W	200.6	Sta. 053	
MR1503-WNS47	Niskin	2015	9	17	19:57	UTC	72	21.324	N	155	23.562	W	999.1	Sta. 053	
MR1503-WNS48	Niskin	2015	9	17	19:57	UTC	72	21.324	N	155	23.562	W	1499.7	Sta. 053	
MR1503-WNS49	Niskin	2015	9	18	8:13	UTC	72	20.508	N	155	23.502	W	5.4	Sta. 053	cast 16
MR1503-WNS50	Niskin	2015	9	18	8:13	UTC	72	20.508	N	155	23.502	W	9.9	Sta. 053	
MR1503-WNS51	Niskin	2015	9	18	8:13	UTC	72	20.508	N	155	23.502	W	20.1	Sta. 053	
MR1503-WNS52	Niskin	2015	9	18	8:13	UTC	72	20.508	N	155	23.502	W	30.1	Sta. 053	
MR1503-WNS53	Niskin	2015	9	18	8:13	UTC	72	20.508	N	155	23.502	W	40.0	Sta. 053	
MR1503-WNS54	Niskin	2015	9	18	8:13	UTC	72	20.508	N	155	23.502	W	49.9	Sta. 053	

MR1503-WNS55	Niskin	2015	9	18	8:13	UTC	72	20.508	N	155	23.502	W	100.0	Sta. 053	
MR1503-WNS56	Niskin	2015	9	18	8:13	UTC	72	20.508	N	155	23.502	W	199.7	Sta. 053	
MR1503-WNS57	Niskin	2015	9	18	8:13	UTC	72	20.508	N	155	23.502	W	500.5	Sta. 053	
MR1503-WNS58	Niskin	2015	9	18	8:13	UTC	72	20.508	N	155	23.502	W	999.5	Sta. 053	
MR1503-WNS59	Niskin	2015	9	20	7:56	UTC	72	16.302	N	155	57.294	W	5.4	Sta. 056	cast 4
MR1503-WNS60	Niskin	2015	9	20	7:56	UTC	72	16.302	N	155	57.294	W	9.9	Sta. 056	
MR1503-WNS61	Niskin	2015	9	20	7:56	UTC	72	16.302	N	155	57.294	W	19.8	Sta. 056	
MR1503-WNS62	Niskin	2015	9	20	7:56	UTC	72	16.302	N	155	57.294	W	29.8	Sta. 056	
MR1503-WNS63	Niskin	2015	9	20	7:56	UTC	72	16.302	N	155	57.294	W	49.8	Sta. 056	
MR1503-WNS64	Niskin	2015	9	20	7:56	UTC	72	16.302	N	155	57.294	W	99.8	Sta. 056	
MR1503-WNS65	Niskin	2015	9	20	7:56	UTC	72	16.302	N	155	57.294	W	200.1	Sta. 056	
MR1503-WNS66	Niskin	2015	9	20	7:56	UTC	72	16.302	N	155	57.294	W	419.0	Sta. 056	
MR1503-WNS67	Niskin	2015	9	21	2:42	UTC	72	16.95	N	155	59.37	W	5.6	Sta. 056	cast 10
MR1503-WNS68	Niskin	2015	9	21	2:42	UTC	72	16.95	N	155	59.37	W	10.1	Sta. 056	
MR1503-WNS69	Niskin	2015	9	21	2:42	UTC	72	16.95	N	155	59.37	W	20.2	Sta. 056	
MR1503-WNS70	Niskin	2015	9	21	2:42	UTC	72	16.95	N	155	59.37	W	30.3	Sta. 056	
MR1503-WNS71	Niskin	2015	9	21	2:42	UTC	72	16.95	N	155	59.37	W	50.2	Sta. 056	
MR1503-WNS72	Niskin	2015	9	21	2:42	UTC	72	16.95	N	155	59.37	W	100.0	Sta. 056	
MR1503-WNS73	Niskin	2015	9	21	2:42	UTC	72	16.95	N	155	59.37	W	200.1	Sta. 056	
MR1503-WNS74	Niskin	2015	9	21	7:55	UTC	72	16.77	N	155	58.536	W	5.7	Sta. 056	cast 12
MR1503-WNS75	Niskin	2015	9	21	7:55	UTC	72	16.77	N	155	58.536	W	10.3	Sta. 056	
MR1503-WNS76	Niskin	2015	9	21	7:55	UTC	72	16.77	N	155	58.536	W	20.3	Sta. 056	
MR1503-WNS77	Niskin	2015	9	21	7:55	UTC	72	16.77	N	155	58.536	W	30.1	Sta. 056	
MR1503-WNS78	Niskin	2015	9	21	7:55	UTC	72	16.77	N	155	58.536	W	50.1	Sta. 056	
MR1503-WNS79	Niskin	2015	9	21	7:55	UTC	72	16.77	N	155	58.536	W	100.3	Sta. 056	
MR1503-WNS80	Niskin	2015	9	21	7:55	UTC	72	16.77	N	155	58.536	W	200.5	Sta. 056	
MR1503-WNS81	Niskin	2015	9	22	11:03	UTC	72	11.154	N	153	33.498	W	5.1	Sta. 060	
MR1503-WNS82	Niskin	2015	9	22	11:03	UTC	72	11.154	N	153	33.498	W	50.0	Sta. 060	
MR1503-WNS83	Niskin	2015	9	22	11:03	UTC	72	11.154	N	153	33.498	W	99.9	Sta. 060	
MR1503-WNS84	Niskin	2015	9	22	11:03	UTC	72	11.154	N	153	33.498	W	202.3	Sta. 060	
MR1503-WNS85	Niskin	2015	9	22	11:03	UTC	72	11.154	N	153	33.498	W	498.7	Sta. 060	
MR1503-WNS86	Niskin	2015	9	22	11:03	UTC	72	11.154	N	153	33.498	W	998.8	Sta. 060	
MR1503-WNS87	Niskin	2015	9	22	11:03	UTC	72	11.154	N	153	33.498	W	1999.3	Sta. 060	
MR1503-WNS88	Niskin	2015	9	24	14:27	UTC	72	34.878	N	159	41.4	W	5.8	Sta. 072	
MR1503-WNS89	Niskin	2015	9	24	14:27	UTC	72	34.878	N	159	41.4	W	11.2	Sta. 072	
MR1503-WNS90	Niskin	2015	9	24	14:27	UTC	72	34.878	N	159	41.4	W	20.9	Sta. 072	
MR1503-WNS91	Niskin	2015	9	24	14:27	UTC	72	34.878	N	159	41.4	W	30.5	Sta. 072	
MR1503-WNS92	Niskin	2015	9	25	5:47	UTC	72	53.238	N	158	48.042	W	5.8	Sta. 077	
MR1503-WNS93	Niskin	2015	9	25	5:47	UTC	72	53.238	N	158	48.042	W	10.4	Sta. 077	
MR1503-WNS94	Niskin	2015	9	25	5:47	UTC	72	53.238	N	158	48.042	W	19.6	Sta. 077	
MR1503-WNS95	Niskin	2015	9	25	5:47	UTC	72	53.238	N	158	48.042	W	30.0	Sta. 077	
MR1503-WNS96	Niskin	2015	9	25	5:47	UTC	72	53.238	N	158	48.042	W	49.6	Sta. 077	

MR1503-WNS97	Niskin	2015	9	25	5:47	UTC	72	53.238	N	158	48.042	W	100.0	Sta. 077	
MR1503-WNS98	Niskin	2015	9	25	5:47	UTC	72	53.238	N	158	48.042	W	151.2	Sta. 077	
MR1503-WNS99	Niskin	2015	9	25	5:47	UTC	72	53.238	N	158	48.042	W	201.2	Sta. 077	
MR1503-WNS100	Niskin	2015	9	25	5:47	UTC	72	53.238	N	158	48.042	W	302.1	Sta. 077	
MR1503-WNS101	Niskin	2015	9	26	4:29	UTC	73	3.48	N	164	36.12	W	5.6	Sta. 084	
MR1503-WNS102	Niskin	2015	9	26	4:29	UTC	73	3.48	N	164	36.12	W	9.9	Sta. 084	
MR1503-WNS103	Niskin	2015	9	26	4:29	UTC	73	3.48	N	164	36.12	W	20.3	Sta. 084	
MR1503-WNS104	Niskin	2015	9	26	4:29	UTC	73	3.48	N	164	36.12	W	30.1	Sta. 084	
MR1503-WNS105	Niskin	2015	9	26	4:29	UTC	73	3.48	N	164	36.12	W	50.7	Sta. 084	
MR1503-WNS106	Niskin	2015	9	26	4:29	UTC	73	3.48	N	164	36.12	W	69.8	Sta. 084	
MR1503-WNS107	Niskin	2015	9	26	19:00	UTC	73	18.618	N	160	45.606	W	4.6	Sta. 085	cast 2
MR1503-WNS108	Niskin	2015	9	26	19:00	UTC	73	18.618	N	160	45.606	W	9.4	Sta. 085	
MR1503-WNS109	Niskin	2015	9	26	19:00	UTC	73	18.618	N	160	45.606	W	19.8	Sta. 085	
MR1503-WNS110	Niskin	2015	9	26	19:00	UTC	73	18.618	N	160	45.606	W	29.8	Sta. 085	
MR1503-WNS111	Niskin	2015	9	26	19:00	UTC	73	18.618	N	160	45.606	W	49.8	Sta. 085	
MR1503-WNS112	Niskin	2015	9	26	19:00	UTC	73	18.618	N	160	45.606	W	99.8	Sta. 085	
MR1503-WNS113	Niskin	2015	9	26	19:00	UTC	73	18.618	N	160	45.606	W	149.8	Sta. 085	
MR1503-WNS114	Niskin	2015	9	26	19:00	UTC	73	18.618	N	160	45.606	W	200.0	Sta. 085	
MR1503-WNS115	Niskin	2015	9	26	19:00	UTC	73	18.618	N	160	45.606	W	300.6	Sta. 085	
MR1503-WNS116	Niskin	2015	9	26	19:00	UTC	73	18.618	N	160	45.606	W	432.6	Sta. 085	
MR1503-WNS117	Niskin	2015	9	28	10:49	UTC	73	34.074	N	165	56.202	W	5.3	Sta. 095	
MR1503-WNS118	Niskin	2015	9	28	10:49	UTC	73	34.074	N	165	56.202	W	10.0	Sta. 095	
MR1503-WNS119	Niskin	2015	9	28	10:49	UTC	73	34.074	N	165	56.202	W	20.3	Sta. 095	
MR1503-WNS120	Niskin	2015	9	28	10:49	UTC	73	34.074	N	165	56.202	W	30.2	Sta. 095	
MR1503-WNS121	Niskin	2015	9	28	10:49	UTC	73	34.074	N	165	56.202	W	50.0	Sta. 095	
MR1503-WNS122	Niskin	2015	9	28	10:49	UTC	73	34.074	N	165	56.202	W	96.9	Sta. 095	
MR1503-WNS123	Niskin	2015	9	29	4:42	UTC	74	0.006	N	168	45.288	W	6.0	Sta. 100	
MR1503-WNS124	Niskin	2015	9	29	4:42	UTC	74	0.006	N	168	45.288	W	10.0	Sta. 100	
MR1503-WNS125	Niskin	2015	9	29	4:42	UTC	74	0.006	N	168	45.288	W	19.9	Sta. 100	
MR1503-WNS126	Niskin	2015	9	29	4:42	UTC	74	0.006	N	168	45.288	W	29.9	Sta. 100	
MR1503-WNS127	Niskin	2015	9	29	4:42	UTC	74	0.006	N	168	45.288	W	39.4	Sta. 100	
MR1503-WNS128	Niskin	2015	9	29	4:42	UTC	74	0.006	N	168	45.288	W	50.3	Sta. 100	
MR1503-WNS129	Niskin	2015	9	29	4:42	UTC	74	0.006	N	168	45.288	W	100.1	Sta. 100	
MR1503-WNS130	Niskin	2015	9	29	4:42	UTC	74	0.006	N	168	45.288	W	150.2	Sta. 100	
MR1503-WNS131	Niskin	2015	9	29	4:42	UTC	74	0.006	N	168	45.288	W	175.0	Sta. 100	
MR1503-WNS132	Niskin	2015	9	30	6:21	UTC	70	59.922	N	168	44.808	W	5.8	Sta. 104	
MR1503-WNS133	Niskin	2015	9	30	6:21	UTC	70	59.922	N	168	44.808	W	10.8	Sta. 104	
MR1503-WNS134	Niskin	2015	9	30	6:21	UTC	70	59.922	N	168	44.808	W	20.4	Sta. 104	
MR1503-WNS135	Niskin	2015	9	30	6:21	UTC	70	59.922	N	168	44.808	W	30.1	Sta. 104	
MR1503-WNS136	Niskin	2015	9	30	6:21	UTC	70	59.922	N	168	44.808	W	39.9	Sta. 104	
MR1503-WNS137	Niskin	2015	10	3	9:19	UTC	67	0.03	N	168	44.892	W	5.2	Sta. 108	
MR1503-WNS138	Niskin	2015	10	3	9:19	UTC	67	0.03	N	168	44.892	W	10.0	Sta. 108	

MR1503-WNS139	Niskin	2015	10	3	9:19	UTC	67	0.03	N	168	44.892	W	20.1	Sta. 108	
MR1503-WNS140	Niskin	2015	10	3	9:19	UTC	67	0.03	N	168	44.892	W	29.9	Sta. 108	

Table 4.7.3-2: List of station/cast for dissolved concentration of CH₄ and CO₂ and δ¹³C of CH₄ and CO₂ in the equilibrated air with seawater by plastic bottle

On board ID	Sampling Method	Date Collected					Latitude			Longitude			Depth [m]	Locality
		YYYY	MM	DD	hh : mm : ss	UTC/JST	Deg.	Min.	N/S	Deg.	Min.	E/W		
MR1503-WNR1	Niskin	2015	9	6	6:37	UTC	65	45.696	N	168	45.198	W	10.2	Sta. 001
MR1503-WNR2	Niskin	2015	9	6	6:37	UTC	65	45.696	N	168	45.198	W	20.2	Sta. 001
MR1503-WNR3	Niskin	2015	9	6	6:37	UTC	65	45.696	N	168	45.198	W	30.3	Sta. 001
MR1503-WNR4	Niskin	2015	9	6	6:37	UTC	65	45.696	N	168	45.198	W	40.0	Sta. 001
MR1503-WNR5	Niskin	2015	9	7	1:26	UTC	67	59.91	N	168	46.644	W	5.3	Sta. 006
MR1503-WNR6	Niskin	2015	9	7	1:26	UTC	67	59.91	N	168	46.644	W	9.9	Sta. 006
MR1503-WNR7	Niskin	2015	9	7	1:26	UTC	67	59.91	N	168	46.644	W	20.0	Sta. 006
MR1503-WNR8	Niskin	2015	9	7	1:26	UTC	67	59.91	N	168	46.644	W	30.0	Sta. 006
MR1503-WNR9	Niskin	2015	9	7	1:26	UTC	67	59.91	N	168	46.644	W	39.6	Sta. 006
MR1503-WNR10	Niskin	2015	9	9	7:08	UTC	71	14.898	N	157	9.666	W	5.1	Sta. 016
MR1503-WNR11	Niskin	2015	9	9	7:08	UTC	71	14.898	N	157	9.666	W	10.2	Sta. 016
MR1503-WNR12	Niskin	2015	9	9	7:08	UTC	71	14.898	N	157	9.666	W	20.0	Sta. 016
MR1503-WNR13	Niskin	2015	9	9	7:08	UTC	71	14.898	N	157	9.666	W	30.2	Sta. 016
MR1503-WNR14	Niskin	2015	9	15	4:14	UTC	72	26.19	N	156	35.454	W	5.6	Sta. 040
MR1503-WNR15	Niskin	2015	9	15	4:14	UTC	72	26.19	N	156	35.454	W	5.6	Sta. 040
MR1503-WNR16	Niskin	2015	9	15	4:14	UTC	72	26.19	N	156	35.454	W	50.1	Sta. 040
MR1503-WNR17	Niskin	2015	9	15	4:14	UTC	72	26.19	N	156	35.454	W	50.1	Sta. 040
MR1503-WNR18	Niskin	2015	9	25	5:47	UTC	72	53.238	N	158	48.042	W	5.8	Sta. 077
MR1503-WNR19	Niskin	2015	9	25	5:47	UTC	72	53.238	N	158	48.042	W	19.6	Sta. 077
MR1503-WNR20	Niskin	2015	9	25	5:47	UTC	72	53.238	N	158	48.042	W	100.0	Sta. 077
MR1503-WNR21	Niskin	2015	9	25	5:47	UTC	72	53.238	N	158	48.042	W	151.2	Sta. 077
MR1503-WNR22	Niskin	2015	9	25	5:47	UTC	72	53.238	N	158	48.042	W	201.2	Sta. 077
MR1503-WNR23	Niskin	2015	10	3	9:19	UTC	67	0.03	N	168	44.892	W	5.2	Sta. 108
MR1503-WNR24	Niskin	2015	10	3	9:19	UTC	67	0.03	N	168	44.892	W	10.0	Sta. 108
MR1503-WNR25	Niskin	2015	10	3	9:19	UTC	67	0.03	N	168	44.892	W	20.1	Sta. 108
MR1503-WNR26	Niskin	2015	10	3	9:19	UTC	67	0.03	N	168	44.892	W	29.9	Sta. 108

(6) Data archives

These data obtained in this cruise will be submitted to the Data Management Group of JAMSTEC, and will be opened to the public via “Data Research System for Whole Cruise Information in JAMSTEC (DARWIN)” in JAMSTEC web site.

(7) Referances

Kondo, F., and O. Tsukamoto. 2007. Air-sea CO₂ flux by eddy covariance technique in the equatorial Indian ocean. *J. Oceanography* 63:449-456.

McInnes, K.J., and J.L. Heilman. 2005. Relaxed eddy accumulation. pp. 437-454. In

Hatfield et al. (eds.) *Micrometeorology in agricultural systems*. Agronomy monograph no. 47. ASA-CSSA-SSSA, Madison, WI.

4.8. VOC/DMS

(1) Personnel

Masao Ishii	Meteorological Research Institute / JMA: PI
Sohiko Kameyama	Hokkaido University
Mahomi Inagawa	Hokkaido University
Bui Thi Ngoc Oanh	Hokkaido University
Hisayuki Yoshikawa	Hokkaido University
Shuji Aoki	Tohoku University
Sakae Toyoda	Tokyo Institute of Technology
Koji Sugie	Japan Agency for Marine-Earth Science and Technology

(2) Objective

Air–sea exchange of volatile organic compounds (VOCs) plays an important role in the earth’s biogeochemical cycles and in the chemistry of the atmosphere. It is known that the Arctic Ocean is sensitive to climate change such as global warming and ocean acidification. To estimate behavior of especially biogenic VOCs in future, it is important to know the distribution of VOCs in the “changing” Arctic Ocean. The variability of phytoplankton activity is large there; therefore, distribution of biogenic VOCs including dimethyl sulfide (DMS) and isoprene should be variable. DMS and isoprene is known as a precursor of cloud condensation nuclei (CCN) over the ocean (Andreae and Raemdonck, 1983; Grenfell et al., 1999), but the degree of its contribution to formation of cloud is still uncertain. In order to investigate the factor controlling the distribution of VOCs especially sulfur compounds and hydrocarbons in surface water column we took seawater samples during the cruise. In addition, we collected seawater samples for measurements of dissolved methane concentration to investigate methane flux from the Alaskan coastal area.

(3) Parameters

- Sulfur compounds including DMS/DMSP and methanethiol
- Hydrocarbons including isoprene and monoterpene
- Methane concentration and its carbon isotopic ratio

(4) Instruments and Methods

Depth samples to 200-m depth were taken approximately once a half day for DMS/DMSP. Samples of VOCs including methanethiol and hydrocarbons were taken 15 times during the cruise. Samples for methane measurements were collected with high special resolution at offshore Barrow. Seawater sample for DMS measurement was subsampled to glass vial bottle with filtration by the GF/F filter and stored at 4°C until the measurement and measured within 3 hours after sampling. Samples for VOCs, DMSP and methane were taken without the filter and overflowed for the twice volume of the sample to avoid contamination. For dissolved DMSP sample, we made gravity filtering in the laboratory according to the method of Kiene and Slezak (2006). Dissolved and particulate DMSP samples were acidified by adding 0.5- and 1.0-mL of HCl solution (5 mol/L) for preservation, respectively. Methane samples were treated with the same manner described in section 4.7.2 “Discrete bottle sampling for CH₄, N₂O and their isotopocules”.

In addition, DMS/DMSP samples were taken from an incubation experiment held onboard. This incubation experiment aims to clarify the influence of acidification, warming and low-salinity of the Arctic seawater to biochemical cycling (see section 4.19. “Clean sampling and incubation” for details). DMS/DMSP samples were treated with the same manner of usual seawater sampling after subsampling.

All samples were measured by gas chromatography (GC) coupling with conventional purge and trap extraction system. Briefly, seawater sample was introduced into a purge bottle and extracted by pure He carrier gas for 14 and 30 minutes for measurements of DMS and VOC, respectively. Extracted gas stream including DMS and VOCs passed through cold dehydration trap (dry ice/ethanol cooled hollow U-shaped glass tube) and concentrated on the cold trap (dry ice/ethanol temperature) with TENAX TA. Concentrated gas was eliminated by replacing the Dewar bottle of from dry ice/ethanol refrigerant to boiled water. Eliminated gas was introduced to GC (GC-2014, Shimadzu) with flame photometric detector (FPD) for DMS and other sulfur compounds and flame ionization detector (FID) for hydrocarbons, respectively.

(5) Station list or Observation log

Table 4.8-1 Sampling stations and depths (m) for each parameter

Station	DMS/DMSP	VOC	Isotope	CH ₄
1	5,10,20,40			
4	5,10,20,40			
6	5,10,20,40	5	5	
10	5,10,20,40			
13	5,10,20,50,94	5		
14				5,10,20,30,40,50,59
15				5,10,20,30,40,50,100,119
16				5,10,20,30,40
22				5,10,20,30
23	5,10,20,50,100,200			5,10,20,30,40,50,100,150,200,250,307
24				5,10,20,30,40,50
25				5,10,20,30,40,50
26				5,10,20,30,40,50,100
27				5,10,20,30,40,50,75
30				5,10,20,30,40,50,100,200,264
31				5,10,20,30,40,50,100,200,500,1000
32	5,10,20,50,100,200			5,10,20,30,40,50,100,200,500
33				5,10,20,30,40,50,100,200,327
35				5,10,20,30,40,50,100,145
37				5,10,20,30,40,50,100,200,351
39	5,10,20,50,100,200			5,10,20,30,40,50,100,200,500,1000,1353
40				5,10,20,30,40,50,100,200,500,859

	47	5,10,20,50			5,10,20,30,40,50
53_4,8,12,16		5,10,20,50,100,200	5		
	54	5,10,20,50,100,200	5		
	55	5,10,20,50,100,200			
56_4,8,10,12,16		5,10,20,50,100,200			
	62	5,10,20,50,100			5,10,20,30,40,50,100
	65	5,10,20,50,100,200			
	71	5,10,20,50,100			
	75	5,10,20,50,100,200			
	77	5,10,20,50,100,200			
	82	5,10,20,50,100,197			
	85	5,10,20,50,100,200	5		
	94	5,10,20,50,100,200			
	95	5,10,20,50,97	5		
	100	5,10,20,50,100,200	5		
	104	5,10,20,30			
	108	5,10,20,30		5	

(6) Preliminary results

We measured all samples for DMS and VOCs concentration. Figure4.8-1-a,b show the vertical distribution of DMS in seawater during the first (sta. 053) and second (sta. 056) 2-days fixed point observations (FPOs). During FPOs observations, we successfully collected samples inside/outside of warm water column (maybe the early stage of eddy?) and eddy. DMS distributions were changed during both 2-days observations. These results obviously suggest that “patchy” distribution of DMS were created by small scale physical variation of water mass such as eddy. We need the further analysis by comparing physicochemical parameters to understand the controlling factors of the features.

Figure4.8-2 shows the time series of DMS concentration during the incubation experiment. The productions of DMS for high temperature (HT) series were higher than those of low temperature (LT) series in general. Samples of low salinity series (LTLs and HTLS) tended to show lower concentration than the other treatments. For further discussion, we need to normalize the concentration data with biological parameter such as production rate of phytoplankton.

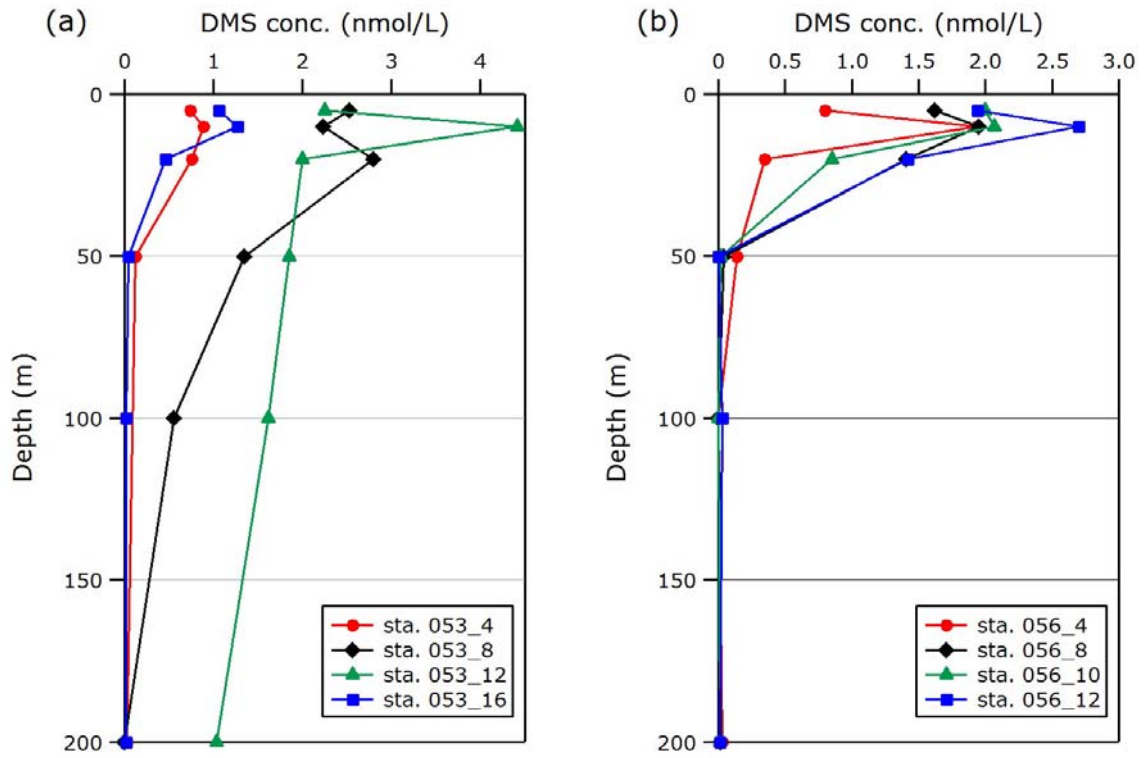

Figure 4.8-1: Vertical distribution of DMS concentration during fixed point observations in (a) sta. 053 and (b) sta. 056.

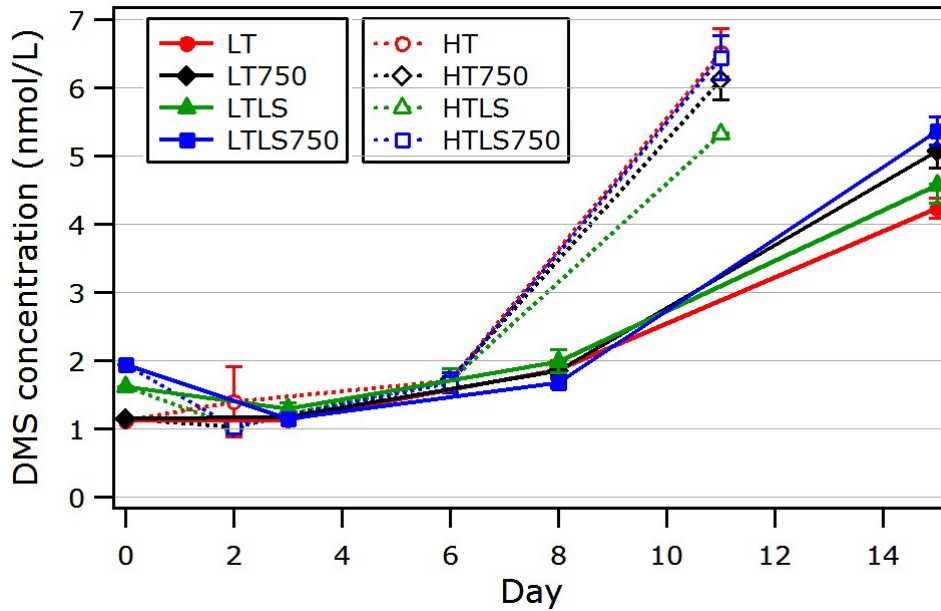

Figure 4.8-2: Time series of DMS concentrations during incubation experiment.

(7) Data archives

These data obtained in this cruise will be submitted to the Data Management Group of JAMSTEC, and will be opened to the public via “Data Research System for Whole Cruise Information in JAMSTEC (DARWIN)” in JAMSTEC web site.

4.9. Perfluoroalkyl substances (PFASs)

(1) Personnel

Nobuyoshi Yamashita	National Institute of Advanced Industrial Science and Technology (AIST)	- PI
Hui GE	AIST	

(2) Objective

Environmentally persistent perfluoroalkyl substances (PFASs, shown in Figure 4.9- 1) have appeared as a new class of global pollutants for the last thirteen years.

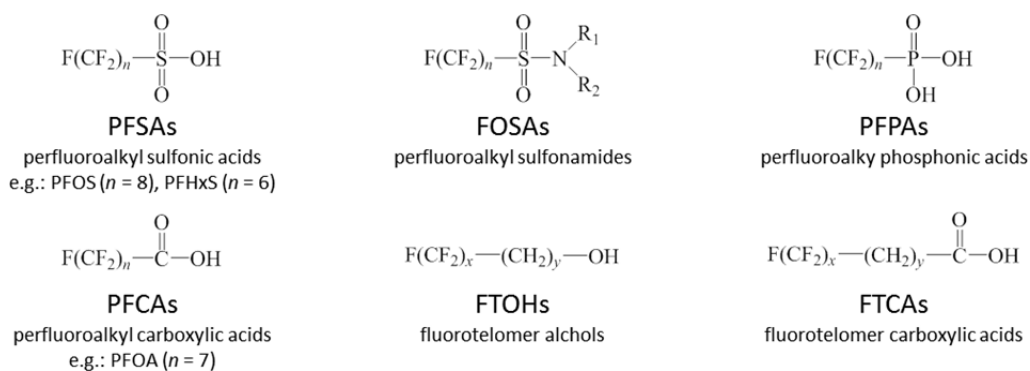

Figure 4.9- 1 Perfluoroalkyl substances (PFASs)

These compounds have recently emerged as a priority environmental pollutant due to its widespread finding in biota including both Arctic and Antarctic species and its persistent and bioaccumulative nature, especially for PFOS (perfluorooctane sulfonate) and PFOA (perfluorooctane carboxylic acid). The physicochemical properties of PFASs, especially of PFASs (perfluoroalkyl sulfonic acids) and PFCAs (perfluoroalkyl carboxylic acids) are unique in that they have high water solubility despite the low reactivity of carbon-fluorine bond, which also imparts high stability in the environment. However, little is known on the distribution of PFASs in the oceans around the world, so far. We have conducted several international joint cruises, including South China Sea and Sulu Seas (KH-02-4), the central to Western Pacific Ocean (KH03-1 and MR11-08), North Pacific Ocean (KH-12-04, MR14-04), Arctic Ocean (MR13-06, MR14-05), North and middle Atlantic Ocean, Southern Pacific and Antarctic Ocean (KH04-5, MR12-05, KH14-06), Labrador Sea and coastal seawater from Asian countries (Japan, China,

Hong Kong, Korea) ^(1, 2, 3). Vertical profiles of PFASs in the marine water column were associated with the global ocean circulation theory. We found that vertical profiles of PFASs in water columns from the Labrador Sea reflected the influx of the North Atlantic Current in surface waters, the Labrador Current in subsurface waters, and the Denmark Strait Overflow Water in deep layers below 2000 m. Striking differences in the vertical and spatial distribution of PFASs, depending on the oceans, suggest that these persistent organic acids can serve as useful chemical tracers to allow us to study oceanic transportation by major water currents. The results provide evidence that PFAS concentrations and profiles in the oceans adhere to a pattern consistent with the global “Broecker’s Conveyor Belt” theory of open ocean water circulation.

In MR15-03 cruise, we will survey PFASs in surface and vertical seawater to understand the Arctic and global distribution of PFASs in Open Ocean environment.

(3) Parameters

Perfluoroalkyl substances (PFASs)

(4) Instruments and Methods

Water samples were stored in clean polypropylene bottles and were kept frozen until analysis. Samples were thawed at room temperature, and a solid phase extraction method using Oasis®WAX-Sea cartridge (500 mg, 30 µm) (Waters Co.) for seawater samples which cartridge was developed specially for open seawater samples by AIST. The HPLC tandem mass spectrometry (HPLC-MS/MS) was used for sample analysis ^(4,5). Briefly, after preconditioning with ammonium hydroxide in methanol, methanol, and then Millipore water, the cartridges were loaded water samples at approximately 1 drop sec⁻¹. Seawater samples were adjusted pH3 by acetic acid and then spiked surrogate standard (1 ng of each compound) before sample loading. The cartridges were then washed with Milli-Q water and then 25 mM ammonium acetate buffer (pH 4) in Milli-Q water and dried. The elution was then divided into two fractions. The first fraction was carried out with methanol and the second with 0.1% ammoniumhydroxide in methanol. Both fractions were reduced to 1 mL under a nitrogen stream and analyzed separately. HPLC-MS/MS, composed of a HP1100 liquid chromatograph (Agilent Technologies, Palo Alto, CA) interfaced with a Micromass® (Beverly, MA) Quattro Ultima Pt mass spectrometer was operated in the electrospray negative ionization mode. A 10-µL aliquot of the

sample extract was injected into a Betasil C18 column (2.1 mm i.d. × 50 mm length, 5 μm; Termo Hypersil-Keystone, Bellefonte, PA). The capillary is held at 1.2 kV. Cone-gas and desolvation-gas flows are kept at 60 and 650 L/h, respectively. Source and desolvation temperatures were kept at 120 and 420°C respectively. MS/MS parameters are optimized so as to transmit the [M-K]⁻ or [M-H]⁻ ions.

(5) Observation log

List of seawater samples (surface, subsurface and deep water) collected were presented in Table 4.9-1 and Table 4.9-1. Deep seawater samples were taken by Conductivity temperature depth profiler-Carousel multiple sampling system (CTD-CMS) attached X-Niskin samplers of 12 L, together with surface seawater samples taken by stainless bucket at all the water sampling stations. Subsurface waters were also collected from the out let tube of surface water analysis facility in MIRAI.

(6) Data archives

These data obtained in this cruise will be submitted to the Data Management Group of JAMSTEC, and will be opened to the public via “Data Research System for Whole Cruise Information in JAMSTEC (DARWIN)” in JAMSTEC web site.

(7) References

- 1) Yamashita N, Kannan K, Taniyasu S, Horii Y, Petrick G, Gamo T, A global survey of perfluorinated acids in oceans, *Marine Pollution Bulletin* 51 (2005) 658–668
- 2) Wei S, Chen LQ, Taniyasu S, So MK, Murphy MB, Yamashita N, Yeung LWY, Lam PKS, Distribution of perfluorinated compounds in surface seawaters between Asia and Antarctica, *Marine Pollution Bulletin* 54 (2007) 1813–1838
- 3) Yamashita N, Taniyasu S, Petrick G, Wei S, Gamo T, Lam PKL, Kannan K, Perfluorinated acids as novel chemical tracers of global circulation of ocean waters, *Chemosphere* 70 (2008) 1247–1255
- 1) Yamashita N, Kannan K, Taniyasu S, Horii Y, Okazawa T, Petrick G, Gamo T, Analysis of Perfluorinated Acids at Parts-Per-Quadrillion Levels in Seawater Using Liquid Chromatography-Tandem Mass Spectrometry, *Environ. Sci. Technol.* (2004) 38, 5522-5528
- 2) Taniyasu S, Kannan K, So MK, Gulkowskad A, Sinclair E, Okazawa T, Yamashita N, Analysis of fluorotelomer alcohols, fluorotelomer acids, and

short- and long-chain perfluorinated acids in water and biota, *Journal of Chromatography A*, 1093 (2005) 89–97

- 3) ISO 25101 (2009 March 1st) Water quality — Determination of perfluorooctanesulfonate (PFOS) and perfluorooctanoate (PFOA) — Method for unfiltered samples using solid phase extraction and liquid chromatography/mass spectrometry

Table 4.9-1: Summary of sub-surface seawater sampling for PFASs analysis

On board ID	Stn	Cast	Date collected					Latitude			Longitude		
			YYYY	MM	DD	hh:mm	UTC/JST/LST	deg	min	N/S	deg	min	E/W
MR15-03-WS01			2015	8	26	12:26	UTC	40	24.0000	N	142	12.0000	E
MR15-03-WS02			2015	9	04	00:29	UTC	59	09.8000	N	178	34.3800	E
MR15-03-WS03			2015	9	5	02:52	UTC	64	02.2200	N	171	39.1800	W
MR15-03-WS04			2015	9	6	04:05	UTC	65	30.0400	N	168	31.0700	W
MR15-03-WS05	1	1	2015	9	6	08:24	UTC	65	47.6100	N	168	46.0100	W
MR15-03-WS06	6	2	2015	9	7	00:14	UTC	68	00.0100	N	168	45.0500	W
MR15-03-WS07	10	1	2015	9	7	18:14	UTC	70	03.1000	N	168	44.6500	W
MR15-03-WS08	12	1	2015	9	8	01:34	UTC	70	59.7800	N	168	45.1300	W
MR15-03-WS09	14	1	2015	9	9	03:15	UTC	71	34.3500	N	157	49.8700	W
MR15-03-WS10	15	1	2015	9	9	04:10	UTC	71	24.8000	N	157	30.0600	W
MR15-03-WS11	16	1	2015	9	9	07:19	UTC	71	14.9100	N	157	09.7300	W
MR15-03-WS12	32	1	2015	9	13	23:27	UTC	71	59.9900	N	154	43.3000	W
MR15-03-WS13	37	1	2015	9	14	12:28	UTC	72	11.0000	N	155	38.9000	W
MR15-03-WS14	39	1	2015	9	14	23:05	UTC	72	23.5400	N	155	26.1100	W
MR15-03-WS15	53	8	2015	9	17	08:00	UTC	72	20.3700	N	155	23.0100	W
MR15-03-WS16	53	12	2015	9	17	19:35	UTC	72	21.3300	N	155	23.6500	W
MR15-03-WS17	53	16	2015	9	18	08:11	UTC	72	20.5100	N	155	23.4800	W
MR15-03-WS18	54	2	2015	9	19	02:11	UTC	72	28.2800	N	155	23.5400	W
MR15-03-WS19	56	4	2015	9	20	07:55	UTC	72	16.3000	N	155	57.2900	W
MR15-03-WS20	56	12	2015	9	21	07:49	UTC	72	16.7500	N	155	58.4700	W
MR15-03-WS21	85	2	2015	9	27	02:19	UTC	73	18.0400	N	160	47.0700	W
MR15-03-WS22	94	1	2015	9	27	23:40	UTC	73	28.4000	N	160	07.6300	W
MR15-03-WS23	98	2	2015	9	28	19:40	UTC	74	27.7620	N	167	37.0320	W
MR15-03-WS24	108	1	2015	10	3	09:19	UTC	67	00.0300	N	168	44.8920	W
MR15-03-WS25			2015	10	4	04:30	UTC	64	01.1200	N	168	04.0300	W
MR15-03-WS26			2015	10	9	22:57	UTC	54	13.7600	N	164	09.7600	W
MR15-03-WS27			2015	10	11	08:11	UTC	53	49.3000	N	176	30.2300	W
MR15-03-WS28			2015	10	12	20:25	UTC	52	38.8700	N	171	28.0100	E
MR15-03-WS29			2015	10	16	07:44	UTC	44	37.2100	N	162	46.9300	E
MR15-03-WS30			2015	10	17	00:18	UTC	43	48.5700	N	159	57.7400	E
MR15-03-WS31			2015	10	18	22:57	UTC	40	11.1400	N	149	18.0800	E
MR15-03-WS32			2015	10	19	10:32	UTC	40	15.9800	N	146	23.9500	E
MR15-03-WS33			2015	10	19	23:41	UTC	40	23.3200	N	143	02.3600	E

4.10. Radionuclides

(1) Personnel

Yuichiro Kumamoto (JAMSTEC): Principal investigator
Hisao Nagai (Nihon University)

(2) Objective

Determination of activity concentrations of radionuclides, including radiocesium and radioiodine.

(3) Parameters

^{134}Cs , ^{137}Cs , and ^{129}I

(4) Instruments and Methods

a. Sampling

Seawater samples for the radionuclides were collected using 12-liter Niskin-X bottles. Surface seawater was collected from continuous pumped-up water from about 4-m depth. The seawater sample was collected into a 20-L plastic container after two time washing. In our laboratory on shore, a seawater sample was divided into two for radiocesium (about 20-L) and radioiodine (about 1-L). The seawater for radiocesium was then acidified by 40-cm³ of concentrated nitric acid. The seawater for radioiodine was siphoned into 1-L plastic bottle.

b. Preparation and analysis

In our laboratory on shore, radiocesium in the seawater samples will be concentrated using ammonium phosphomolybdate (AMP) that forms insoluble compound with cesium. The radiocesium (^{134}Cs and ^{137}Cs) in AMP will be measured using Ge γ -ray spectrometer. Measurements of radioiodine will be also conducted at our laboratory on shore. Iodine in the seawater samples is extracted by the solvent extraction technique. Extracted iodine is then precipitated as silver iodide by the addition of the silver nitrate. Iodine isotopic ratios ($^{129}\text{I}/^{127}\text{I}$) of the silver iodide are measured by the Accelerator Mass Spectrometry (AMS). To evaluate the ^{129}I concentration in the seawater samples, iodine concentration (^{127}I) will be measured by the inductively coupled plasma mass spectrometry (ICP-MS) and/or the voltammetry.

(5) Sample list

We collected 27 seawaters for the radionuclide measurement in the Arctic Ocean, Bering Sea, and northern North Pacific Ocean during this cruise (Table 4.10-1).

(6) Data archives

These data obtained in this cruise will be submitted to the Data Management Group

of JAMSTEC, and will be opened to the public via “Data Research System for Whole Cruise Information in JAMSTEC (DARWIN)” in JAMSTEC web site.

Table 4.10-1: Seawater samples collected for the radionuclides measurement.

No.	Station	Sampling depth (m)	Method	Latitude (N)	Longitude (E)	Date (UTC)
1	surface	4	pump	71.06	193.14	08-Sep-15
2	surface	4	pump	71.84	205.50	10-Sep-15
3	surface	4	pump	72.40	203.47	12-Sep-15
4	surface	4	pump	71.76	204.83	14-Sep-15
5	surface	4	pump	72.34	204.62	16-Sep-15
6	surface	4	pump	72.30	204.84	18-Sep-15
7	054-3	5	niskin	72.48	204.60	19-Sep-15
8	054-3	25	niskin	72.48	204.60	19-Sep-15
9	054-3	50	niskin	72.48	204.60	19-Sep-15
10	054-3	100	niskin	72.48	204.60	19-Sep-15
11	054-3	150	niskin	72.48	204.60	19-Sep-15
12	054-3	200	niskin	72.48	204.60	19-Sep-15
13	054-3	300	niskin	72.48	204.60	19-Sep-15
14	054-3	400	niskin	72.48	204.60	19-Sep-15
15	054-3	600	niskin	72.48	204.60	19-Sep-15
16	054-3	800	niskin	72.48	204.60	19-Sep-15
17	surface	4	pump	72.28	204.01	20-Sep-15
18	surface	4	pump	72.21	205.36	22-Sep-15
19	surface	4	pump	72.33	201.85	24-Sep-15
20	surface	4	pump	73.17	197.04	26-Sep-15
21	surface	4	pump	73.55	195.31	28-Sep-15
22	surface	4	pump	70.66	191.25	30-Sep-15
23	surface	4	pump	68.06	191.10	02-Oct-15
24	surface	4	pump	63.85	192.07	04-Oct-15
25	surface	4	pump	53.99	187.26	10-Oct-15
26	surface	4	pump	49.23	168.90	13-Oct-15
27	surface	4	pump	43.93	160.33	16-Oct-15

4.11. Chlorophyll *a*

(1) Personnel

Shigeto Nishino (JAMSTEC): Principal Investigator

Amane Fujiwara (JAMSTEC)

Misato Kuwahara (MWJ): Operation Leader

Masahiro Orui (MWJ)

Kenzaburo Sawano (MWJ)

Nobuhiro Anraku (MWJ)

(2) Objective

Phytoplankton distributes in various species and sizes in the ocean were examined. Phytoplankton species are roughly characterized by the cell size. The objective of this study is to investigate the vertical and horizontal distributions of phytoplankton biomass and size in the Arctic Ocean, in terms of phytoplankton pigment, chlorophyll *a*, by using the size-fractionated filtration method.

(3) Parameters

Total chlorophyll *a*

Size-fractionated chlorophyll *a*

(4) Instruments and methods

We collected samples for total chlorophyll *a* (chl-*a*) from 7 to 14 depths and size-fractionated chl-*a* from 5 to 12 depths between the surface and 200 m depth including a chl-*a* maximum layer. The chl-*a* maximum layer was determined by a fluorometer (Seapoint Sensors, Inc.) attached to the CTD system.

Water samples for total chl-*a* were vacuum-filtrated (<0.02MPa) through 25mm-diameter Whatman GF/F filter. Water samples for size-fractionated chl-*a* were passed through 20 μm pore-size Nylon filter (47 mm in diameter), 10μm and 2μm pore-size nuclepore filters (47 mm in diameter), and Whatman GF/F filter (25 mm in diameter) under gentle vacuum (<0.02MPa). In an intensive observation area of the eddy that was focused on in the present cruise, water samples for size-fractionated chl-*a* were passed through 20 μm pore-size Nylon filter (47 mm in diameter), 10μm pore-size nuclepore filter (47 mm in diameter), and Whatman GF/F filter (25 mm in diameter). Phytoplankton pigments retained on the filters were immediately extracted in a polypropylene tube with 7 ml of N,N-dimethylformamide. The tubes were stored at

–20°C under the dark condition to extract chl-*a* at least for 24 hours.

Fluorescences of each sample were measured by Turner Design fluorometer (10-AU-005), which was calibrated against a pure chl-*a* (Sigma chemical Co.). We applied fluorometric determination for the samples of chl-*a* “Non-acidification method” (Welschmeyer, 1994). Analytical conditions of this method were listed in Table 4.11-1.

(5) Station list

Samples for total and size-fractionated chl-*a* were collected at 94 (see Fig. 4.11-1) and 40 casts (see Fig. 4.11-2), respectively. The numbers of samples for total and size-fractionated chl-*a* were 1214 and 1511, respectively. Water samples in the eddy area for size-fractionated chl-*a* were collected at 9 casts (see Fig. 4.11-3).

(6) Preliminary results

At each station, water samples were taken in replicate for water of 5 m and chl-*a* maximum layer. The CV (coefficient of variance) was 2.6 % (n = 156), and the relative error was 4 % (n = 156).

(7) Data archives

These data obtained in this cruise will be submitted to the Data Management Group of JAMSTEC, and will be opened to the public via “Data Research System for Whole Cruise Information in JAMSTEC (DARWIN) in JAMSTEC web site.

<<http://www.godac.jamstec.go.jp/darwin/e>>

(8) Reference

Welschmeyer, N. A. (1994): Fluorometric analysis of chlorophyll *a* in the presence of chlorophyll *b* and pheopigments. *Limnol. Oceanogr.*, 39, 1985–1992.

Table 4.11-1. Analytical conditions of non-acidification method for chlorophyll *a* with Turner Design fluorometer (10-AU-005).

	Non-acidification method
Excitation filter (nm)	436
Emission filter (nm)	680
Lamp	Blue F4T5,B2/BP

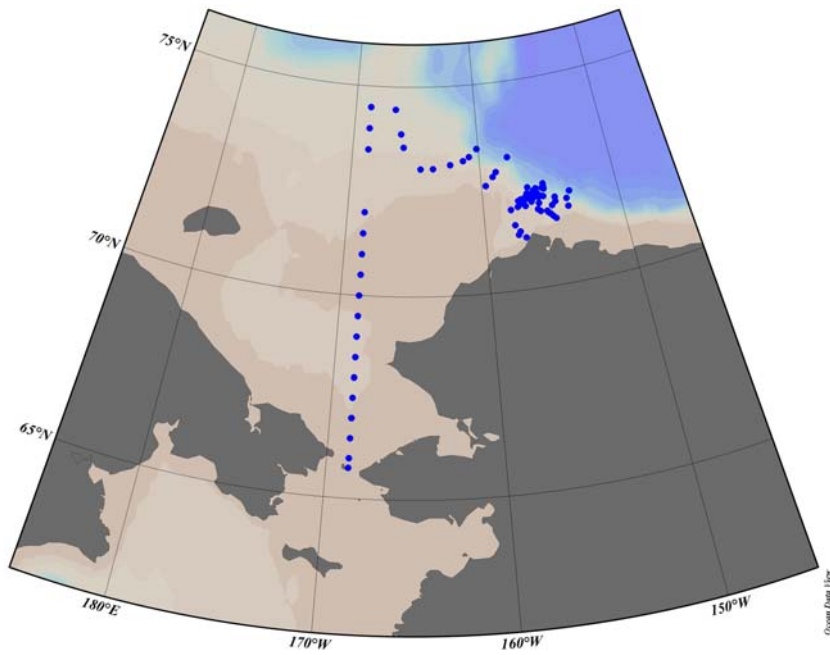

Figure 4.11-1. Sampling positions of total chlorophyll *a*.

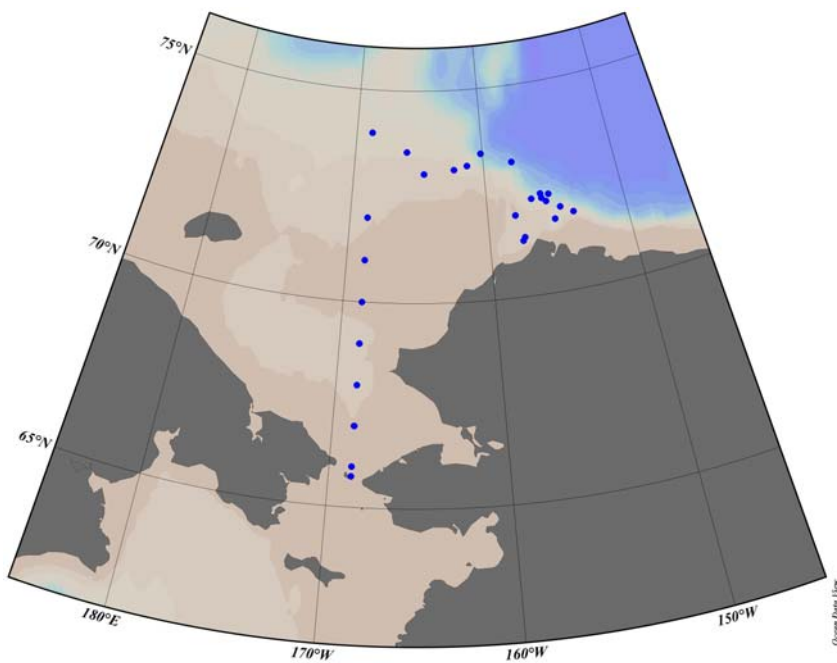

Figure 4.11-2. Sampling positions of size-fractionated chlorophyll *a*.

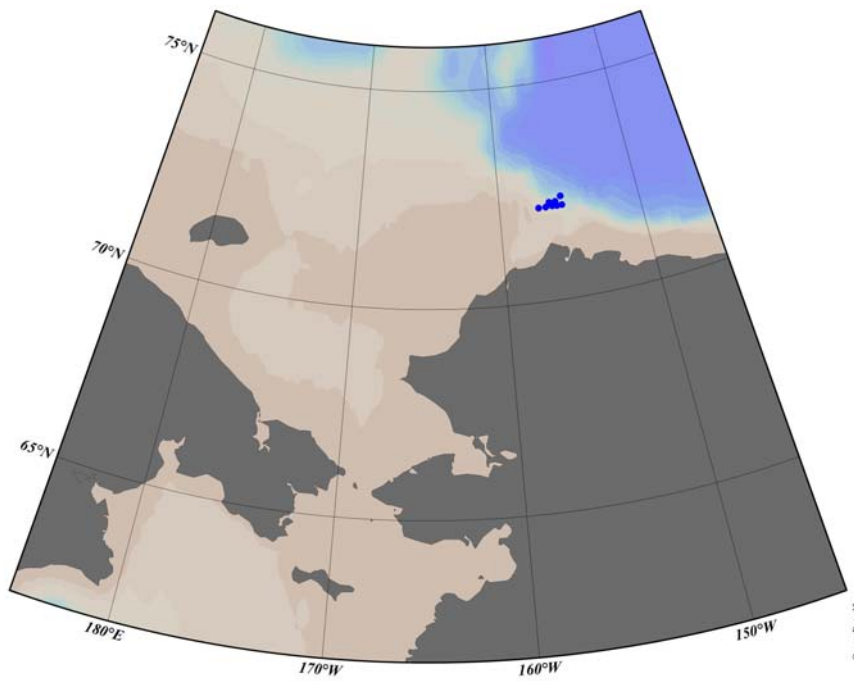

Figure 4.11-3. Sampling positions of size-fractionated chlorophyll *a* in the eddy area.

4.12. Phytoplankton pigments

(1) Personnel

Amane Fujiwara JAMSTEC

(2) Objectives

To investigate vertical and horizontal distribution of phytoplankton community structure corresponding to other oceanic environmental parameters (e.g., temperature, salinity and nutrients), the samples of phytoplankton pigment composition were collected.

(3) Parameters

Phytoplankton pigments

(4) Instruments and methods

Seawater samples for phytoplankton pigments were collected from the sea surface and several depths shallower than 75 m using a bucket or Niskin-X bottles on a CTD/Carousel Multi Sampler (Sea-Bird Electronics Inc.). 1–4 liters of water sample were filtered on a glass fiber filter (Whatman GF/F, 47 mm) and stored in liquid nitrogen for at least 1 day and then stored in a super freezer (-80°C). Pigments concentration will be analyzed on land with using performance liquid chromatography (HPLC) after the cruise.

(5) Station list or Observation log

Table 4.12-1: List of station/cast for HPLC

Table 4.12-1: List of station/cast for HPLC

Date	Station ID	CTD cast No	lat (N)	long (W)
09/06/2015	001	1	65.762	168.753
09/07/2015	006	2	67.999	168.777
09/07/2015	011	1	70.502	168.752
09/08/2015	013	1	71.335	157.665
09/11/2015	023	2	71.774	155.331
09/14/2015	032	2	72.003	154.761
09/15/2015	039	2	72.392	155.467
09/15/2015	047	1	71.952	158.001
09/16/2015	053	4	72.340	155.392
09/17/2015	053	12	72.355	155.393
09/18/2015	054	2	72.471	155.391
09/19/2015	055	1	72.382	155.996
09/20/2015	056	4	72.272	155.955
09/20/2015	056	8	72.293	156.027
09/21/2015	056	10	72.283	155.990
09/21/2015	056	12	72.280	155.976
09/21/2015	056	16	72.282	155.985
09/22/2015	062	1	71.832	153.825
09/23/2015	063	1	72.371	155.519
09/23/2015	064	1	72.265	155.966
09/23/2015	065	1	72.195	156.258
09/23/2015	066	1	72.267	156.415
09/23/2015	067	1	72.168	155.515
09/24/2015	068	1	72.175	156.224
09/24/2015	069	1	72.168	155.875
09/24/2015	070	1	72.168	156.679
09/24/2015	071	1	72.168	157.187
09/24/2015	075	1	73.209	157.804
09/25/2015	081	1	73.214	161.264
09/26/2015	085	2	73.310	160.760
09/27/2015	094	1	73.476	160.136
09/28/2015	098	2	74.463	166.617
09/29/2015	102	1	72.002	168.746
09/30/2015	104	1	70.999	168.747
10/01/2015	106	1	67.998	168.747
10/03/2015	108	1	67.001	168.748

(6) Data archives

These data obtained in this cruise will be submitted to the Data Management Group of JAMSTEC, and will be opened to the public via “Data Research System for Whole Cruise Information in JAMSTEC (DARWIN)” in JAMSTEC web site.

<<http://www.godac.jamstec.go.jp/darwin/e>>

4.13. Optical measurements (PRR & LI-190R)

(1) Personnel

Amane Fujiwara	JAMSTEC: -PI
Shigeto Nishino	JAMSTEC

(2) Objectives

In-water spectroradiometer (PRR-800, Biospherical) was used to investigate the vertical distribution of spectral downwelling irradiance $E_d(\lambda, z)$ ($\mu\text{W cm}^{-2} \text{ nm}^{-1}$) and upwelling radiance $L_u(\lambda, z)$ ($\mu\text{W cm}^{-2} \text{ nm}^{-1} \text{ str}^{-1}$). $E_d(\lambda, z)$ was also used to determine the optical depth for water sampling of primary production measurement (4.14). Downwelling photosynthetically available radiation (PAR) (400–700 nm) incident irradiance was continuously monitored using quantum sensor (Li190R). Daily incident PAR and day length were determined from monitored PAR value.

(3) Parameters

- A) Underwater spectral irradiance and radiance (PRR)
- B) Incident photosynthetic available radiation (PAR)

(4) Instruments and methods

- A) Underwater spectral irradiance and radiance (PRR-800/810)

$E_d(\lambda, z)$ and $L_u(\lambda, z)$ at 17 wavelengths over 380–765 nm and downwelling PAR were measured with a spectroradiometer, PRR-800 (Biospherical Instrument Inc.). The PRR-800 was deployed in free-fall mode up to 80 m deep distancing from the stern of ship to avoid her shadow. Incident downwelling irradiance to sea surface $E_d(\lambda, 0^+)$ ($\mu\text{W cm}^{-2} \text{ nm}^{-1}$) was monitored by reference spectroradiometer, PRR-810 (Biospherical Instrument Inc.) with same specification as the underwater sensor. Before each deployment of the instrument, 10 minutes averaged dark values were recorded.

- B) Incident photosynthetic available radiation (PAR)

Incident PAR, $E_q(0^+)$, was monitored with a LI-190R air quantum sensor. Mean value for five minutes was recorded to a LI-1500 data logger (LICOR Inc.) during the cruise.

(5) Station list

Table 4.13-1: Station and cast where PRR observation conducted

Table 4.13-1: Station and cast where PRR observation conducted

Station ID	lon(N)	lat(E)	Start Date(UTC)	Weather	Bot.Dpth (m)
001	65.76	191.25	2015/9/6 6:11	o	52
006	68.00	191.25	2015/9/7 0:43	o	59
011	70.50	191.25	2015/9/7 20:52	o	39
013	71.34	202.34	2015/9/8 23:06	o	99
023	71.74	204.79	2015/9/11 17:20	o	307
032	72.00	205.29	2015/9/13 21:40	o	1008
039	72.39	204.60	2015/9/14 21:37	c	1448
047	71.95	202.00	2015/9/15 18:46	c	66
053	72.34	204.61	2015/9/16 19:24	o	1619
054	72.47	204.60	2015/9/18 19:05	c	2004
055	72.38	204.00	2015/9/19 19:16	c	1375
056	72.29	203.97	2015/9/20 19:18	bc	917
062	71.83	206.18	2015/9/22 18:17	bc	173
068	72.17	203.78	2015/9/24 0:01	c	242
074	72.78	200.90	2015/9/24 22:06	o	183
082	73.14	197.70	2015/9/25 21:02	o	201
085	73.31	199.22	2015/9/26 17:06	o	428
094	73.48	199.86	2015/9/27 21:20	bc	1615
098	74.46	193.36	2015/9/28 17:48	s	314
102	72.00	191.25	2015/9/29 22:04	bc	51

(6) Data archives

These data obtained in this cruise will be submitted to the Data Management Group of JAMSTEC, and will be opened to the public via “Data Research System for Whole Cruise Information in JAMSTEC (DARWIN)” in JAMSTEC web site.

<<http://www.godac.jamstec.go.jp/darwin/e>>

4.14. Primary production

(1) Personnel

Shigeto Nishino (JAMSTEC): Principal Investigator

Amane Fujiwara (JAMSTEC)

Keitaro Matsumoto (MWJ): Operation Leader

Hiroshi Hoshino (MWJ)

(2) Objectives

Primary production was measured to estimate underwater photosynthesis by phytoplankton in the Arctic Ocean.

(3) Parameters

Primary production

(4) Instruments and methods

a. Instruments

Stable isotope analyzer

ANCA-SL by Europa Scientific Ltd.; now SerCon Ltd.

Software

ANCA Ver.3.6

b. Methods

Primary production was measured at 13 stations (Sta. 001, 006, 023, 032, 039, 053, 054, 055, 062, 068, 082, 085 and 098) by simulated in situ incubation method (See Fig. 4.14-1 and Table 4.14-1). We sampled seawater using shading and acid-treatment bottles and tubes connected to the Niskin bottles, which are derived from 7 optical depths, 100%, 42%, 17%, 7%, 3%, 1.5% and 0.5% of surface irradiance.

After sampling, the seawater was dispensed into four 1L Nalgene polycarbonate bottles for incubation in a dark room (Duplicate for the light level controlled incubation, and in a single for the dark incubation and isotope ratio of ^{13}C of ambient seawater). The isotope ratio of ^{13}C of ambient seawater sample was filtered immediately onto GF/F filter. The Nalgene bottles were used after acid treatment. These seawater samples were inoculated with labeled carbon substrate ($\text{NaH}^{13}\text{CO}_3$) for the measurements of primary production. The concentration of labeled carbon ($\text{NaH}^{13}\text{CO}_3$) was 200 μM that was ca. 10 % enrichment to the total inorganic carbon in the ambient water. The bottles

were placed into incubators with neutral density filters corresponding to light levels at the seawater sampling depths. Incubations using dark bottles were also conducted at each light level.

Samples for the measurements of primary production were incubated in a bath on the deck for 24 hours. At the end of the incubation period, samples were filtered through glass fiber filters (Whatman GF/F 25mm, pre-combusted under 450 degC over 4 hours). The filters were kept to freeze -20 degC until measurements. Before the measurements, the filters were oven-dried at 45 degC for at least 20 hours and treated with hydrochloric acid to remove the inorganic carbon. The measurements were performed on board the ship using a stable isotope analyzer (ANCA-SL, Europa Scientific Ltd.; now SerCon Ltd.).

(5) Station list

Table 4.14-1 shows a station list for the measurement of primary production, date, and positions.

(6) Preliminary results

We re-measured the light levels of incubation bottles after the observations, but we found that pre-measurements of light level of incubation bottle were wrong for 7 and 1.5% optical depths for all stations and 3% optical depth for the first 5 stations. Therefore, we gave quality flag=4 (bad measurement) for the samples collected at these depths.

(7) Data archives

These data obtained in this cruise will be submitted to the Data Management Group of JAMSTEC, and will be opened to the public via “Data Research System for Whole Cruise Information in JAMSTEC (DARWIN)” in JAMSTEC web site.

<<http://www.godac.jamstec.go.jp/darwin/e>>

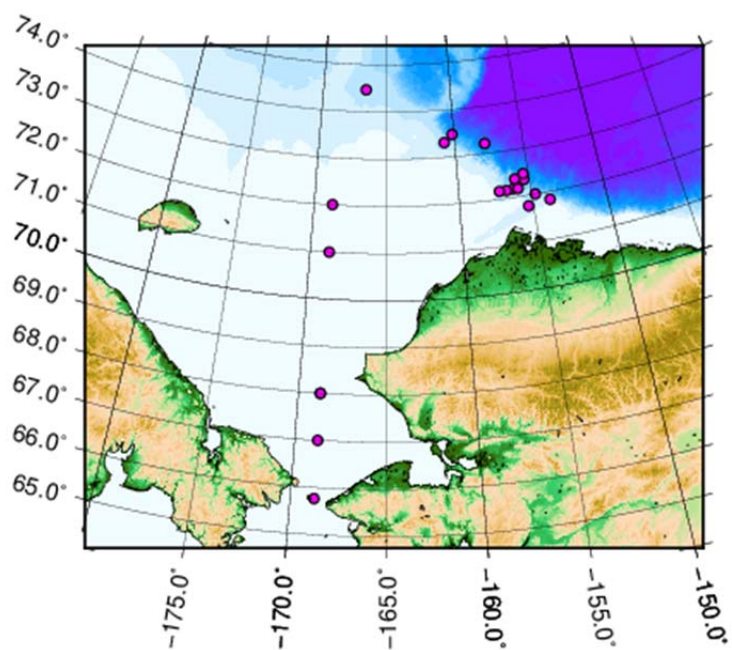

Fig. 4.14-1. Map of stations for the measurements of primary production.

Table 4.14-1. List of stations, date, and positions.

Station	Cast	Date(UTC)	Latitude	Longitude
001	01	9/6	65-45.70N	168-45.20W
006	02	9/7	67-59.91N	168-46.65W
023	02	9/11	71-46.42N	155-19.84W
032	02	9/14	72-19.20N	154-45.66W
039	01	9/14	72-23.49N	155-24.17W
053	04	9/16	72-20.43N	155-23.50W
054	01	9/18	72-28.37N	155-24.09W
055	01	9/19	72-22.94N	155-59.77W
062	02	9/22	71-49.94N	153-48.99W
068	01	9/24	72-10.48N	156-13.46W
082	01	9/25	73-08.16N	162-17.92W
085	01	9/26	73-18.31N	160-46.75W
098	01	9/28	74-27.71N	166-38.14W

4.15. New production

(1) Personnel

Koji Hamasaki: Atmosphere and Ocean Research Institute, Univ. Tokyo -PI

Toshi Nagata: Atmosphere and Ocean Research Institute, Univ. Tokyo

Takuhei Shiozaki: Atmosphere and Ocean Research Institute, Univ. Tokyo

Minoru Ijichi: Atmosphere and Ocean Research Institute, Univ. Tokyo

(2) Objectives

The ocean contains the largest active reservoir of carbon on Earth and determines atmospheric carbon dioxide. Understanding the efficiency and the factors limiting the carbon export from the sunlit surface waters to the ocean interior is consequently essential for tracing anthropogenic carbon dioxide which causes global warming and ocean acidification. The efficiency of microbe-mediated carbon sequestration, the biological carbon pump, is commonly evaluated by comparing so-called new production with primary production. Marine primary production is generally limited by nitrogen availability, and scales with the input of new nitrogen to the photic zone. New production is defined as production based on nitrogenous nutrient newly introduced from outside of the productive layer, and is balanced with sinking particle flux in a steady-state system. To elucidate spatial variation of new production in the Arctic Ocean, we conducted following experiments during this cruise.

(3) Parameters

Nitrogen fixation rate

Nitrate assimilation rate

Ammonium assimilation rate

Ammonia oxidation rate

Primary production

Chlorophyll *a*

Nutrients

Microbial community (microscopy, DNA, and RNA)

(4) Instruments and methods

Water samples for incubation experiments, nutrients, chlorophyll *a*, microscopic observation, and DNA analysis were collected in an acid-cleaned bucket and Niskin-X bottles from those layers having surface light intensities of 100, 10, 1, and 0.1%. Further, samples for nitrification were collected from one additional depths, which were 100 m or bottom depth minus 10 m when the bottom was less than 100 m. The depth profiles of light intensity were obtained using PRR-800 (Biospherical Instruments) before the sampling.

Nitrogen fixation, nitrate assimilation, ammonium assimilation, and nitrification

rates were evaluated using ^{15}N tracer. Nitrogen fixation rate was determined by the gas dissolution method (Mohr et al., 2010, PLoS one). Primary production was determined using ^{13}C tracer. After addition of the tracers, the incubation bottles were placed into on-deck incubators cooled by flowing surface seawater. Light levels were adjusted using neutral-density screens. Samples of 4.5 L collected for estimating the initial ^{15}N and ^{13}C enrichment of particulate organic matter were filtered immediately at the beginning of the incubation. The incubations for nitrogen fixation, nitrate assimilation, and ammonia assimilation were terminated by gentle vacuum filtration of the seawater samples through a precombusted GF/F filter. Those for nitrification were terminated by filtration using 0.2 μm pore-size filters, and filtrate was collected. The filters and filtrate were kept frozen ($-20\text{ }^{\circ}\text{C}$) for on-shore analysis.

Samples for nutrients analysis were collected in 10 mL acrylic tubes and were immediately determined on board using a QuAAtro system (see a report of S. Nishino and colleagues in this issue). Samples for chlorophyll *a* of 290 ml were filtered onto 25-mm Whatman GF/F filters, and the chlorophyll *a* concentrations were measured fluorometrically using a Turner Design 10-AU fluorometer after extraction with N^{\prime} , N^{\prime} -dimethylformamide on board. Samples for microscopic observation were collected in 500-ml PP bottles and were preserved with acidified Lugol's solution. Samples for DNA and RNA analyses were filtered onto Sterivex-GP pressure filter units with a 0.22 μm pore size (Millipore). RNA samples were filtered within 30 min of the water sampling and then added to RNA*later* Stabilization Solution (Life Technologies). The Sterivex filter units were frozen at -80°C until onshore analyses.

(5) Data archives

These data obtained in this cruise will be submitted to the Data Management Group of JAMSTEC, and will be opened to the public via "Data Research System for Whole Cruise Information in JAMSTEC (DARWIN)" in JAMSTEC web site.

4.16. FRRF measurement

(1) Personnel

Fumihito Itoh (JAMSTEC / University of Tsukuba)

Naomi Harada (JAMSTEC): PI

(2) Objectives

In the Arctic ocean shelf region and Chukchi sea, the marine primary production is usually higher than the low latitude ocean. We used FRRF to investigate photosynthetic and light response property in Arctic Ocean.

(3) Parameters

F_v/F_m : Ratio of effective PhotoSystemII reaction centers

σ PSII: Effective absorption cross section

rETR: Relative photosynthetic electron transport rates

(4) Instruments and methods

Water samples were taken by bucket and CTD niskin sampler. Water samples for FRRF analysis were adapted in dark(10-min adaptation before exposure). FRRF were measured by double modulation fluorometer FL-3500 with FastHead (Photonsystem Inc.Cz). Measurement method was Rapid light curve mode. Measurement condition was described in Table 4.16-1.

Table 4.16-1: FRRF measurement condition

FRRF instrument settings	
pulse intensity	50,000 μE
pulse duration	5 μsec
pulse interval	2 μsec
number of flash	120 times
light curve duration	25 sec
Actinic light intensity step1	0 μE
Actinic light intensity step2	56.9 μE
Actinic light intensity step3	74.9 μE
Actinic light intensity step4	92.9 μE
Actinic light intensity step5	110 μE
Actinic light intensity step6	128 μE
Actinic light intensity step7	200 μE
Actinic light intensity step8	380 μE
Actinic light intensity step9	560 μE

Actinic light intensity step10	1010 μ E
Actinic light intensity step11	1741 μ E

(5) Station list or Observation log

40 stations were made in the MR15-03 cruise. Details are shown in Table 4.16-2.

Table 4.16-2: Information of FRRF observation.

Station No.	Sampling Method	Latitude			Longitude			Depth [m]
		Deg.	Min.	N/S	Deg.	Min.	E/W	
st.01	Bucket sampling	65	45.8	N	168	45.6	W	0
st.01	Niskin Sampler	65	45.8	N	168	45.6	W	10
st.01	Niskin Sampler	65	45.8	N	168	45.6	W	20
st.01	Niskin Sampler	65	45.8	N	168	45.6	W	30
st.01	Niskin Sampler	65	45.8	N	168	45.6	W	40
st.04	Bucket sampling	67	0	N	168	45	W	0
st.04	Niskin Sampler	67	0	N	168	45	W	10
st.04	Niskin Sampler	67	0	N	168	45	W	20
st.04	Niskin Sampler	67	0	N	168	45	W	30
st.04	Niskin Sampler	67	0	N	168	45	W	40
st.05	Bucket sampling	67	30	N	168	45	W	0
st.05	Niskin Sampler	67	30	N	168	45	W	10
st.05	Niskin Sampler	67	30	N	168	45	W	20
st.05	Niskin Sampler	67	30	N	168	45	W	30
st.05	Niskin Sampler	67	30	N	168	45	W	40
st.06	Bucket sampling	68	0	N	168	45	W	0
st.06	Niskin Sampler	68	0	N	168	45	W	10
st.06	Niskin Sampler	68	0	N	168	45	W	20
st.06	Niskin Sampler	68	0	N	168	45	W	30
st.06	Niskin Sampler	68	0	N	168	45	W	40
st.07	Bucket sampling	68	30	N	168	45	W	0
st.07	Niskin Sampler	68	30	N	168	45	W	10
st.07	Niskin Sampler	68	30	N	168	45	W	20
st.07	Niskin Sampler	68	30	N	168	45	W	30
st.07	Niskin Sampler	68	30	N	168	45	W	40
st.10	Bucket sampling	70	0	N	168	45	W	0
st.10	Niskin Sampler	70	0	N	168	45	W	10
st.10	Niskin Sampler	70	0	N	168	45	W	20
st.10	Niskin Sampler	70	0	N	168	45	W	30

st.11	Bucket sampling	70	30	N	168	45	W	0
st.11	Niskin Sampler	70	30	N	168	45	W	10
st.11	Niskin Sampler	70	30	N	168	45	W	20
st.11	Niskin Sampler	70	30	N	168	45	W	30
st.12	Bucket sampling	71	0	N	168	45	W	0
st.12	Niskin Sampler	71	0	N	168	45	W	10
st.12	Niskin Sampler	71	0	N	168	45	W	20
st.12	Niskin Sampler	71	0	N	168	45	W	30
st.13	Bucket sampling	71	20	N	157	40	W	0
st.13	Niskin Sampler	71	20	N	157	40	W	10
st.13	Niskin Sampler	71	20	N	157	40	W	20
st.13	Niskin Sampler	71	20	N	157	40	W	30
st.13	Niskin Sampler	71	20	N	157	40	W	40
st.13	Niskin Sampler	71	20	N	157	40	W	50
st.13	Niskin Sampler	71	20	N	157	40	W	75
st.13	Niskin Sampler	71	20	N	157	40	W	8
st.14	Bucket sampling	71	34.7	N	157	50.3	W	0
st.14	Niskin Sampler	71	34.7	N	157	50.3	W	10
st.14	Niskin Sampler	71	34.7	N	157	50.3	W	20
st.14	Niskin Sampler	71	34.7	N	157	50.3	W	30
st.14	Niskin Sampler	71	34.7	N	157	50.3	W	40
st.14	Niskin Sampler	71	34.7	N	157	50.3	W	50
st.14	Niskin Sampler	71	34.7	N	157	50.3	W	51
st.15	Bucket sampling	71	24.8	N	157	29.9	W	0
st.15	Niskin Sampler	71	24.8	N	157	29.9	W	10
st.15	Niskin Sampler	71	24.8	N	157	29.9	W	20
st.15	Niskin Sampler	71	24.8	N	157	29.9	W	30
st.15	Niskin Sampler	71	24.8	N	157	29.9	W	40
st.15	Niskin Sampler	71	24.8	N	157	29.9	W	50
st.15	Niskin Sampler	71	24.8	N	157	29.9	W	75
st.15	Niskin Sampler	71	24.8	N	157	29.9	W	115
st.15	Niskin Sampler	71	24.8	N	157	29.9	W	14
st.22	Bucket sampling	71	35.52	N	154	48.78	W	0
st.22	Niskin Sampler	71	35.52	N	154	48.78	W	10
st.22	Niskin Sampler	71	35.52	N	154	48.78	W	20
st.22	Niskin Sampler	71	35.52	N	154	48.78	W	30
st.22	Niskin Sampler	71	35.52	N	154	48.78	W	29

st.23	Bucket sampling	71	44.1	N	155	11.88	W	0
st.23	Niskin Sampler	71	44.1	N	155	11.88	W	10
st.23	Niskin Sampler	71	44.1	N	155	11.88	W	20
st.23	Niskin Sampler	71	44.1	N	155	11.88	W	30
st.23	Niskin Sampler	71	44.1	N	155	11.88	W	75
st.23	Niskin Sampler	71	44.1	N	155	11.88	W	125
st.23	Niskin Sampler	71	44.1	N	155	11.88	W	200
st.23	Niskin Sampler	71	44.1	N	155	11.88	W	24
st.24	Bucket sampling	71	52.62	N	156	2.28	W	0
st.24	Niskin Sampler	71	52.62	N	156	2.28	W	10
st.24	Niskin Sampler	71	52.62	N	156	2.28	W	20
st.24	Niskin Sampler	71	52.62	N	156	2.28	W	30
st.24	Niskin Sampler	71	52.62	N	156	2.28	W	40
st.24	Niskin Sampler	71	52.62	N	156	2.28	W	50
st.24	Niskin Sampler	71	52.62	N	156	2.28	W	35
st.25	Bucket sampling	71	49.5	N	155	50.1	W	0
st.25	Niskin Sampler	71	49.5	N	155	50.1	W	10
st.25	Niskin Sampler	71	49.5	N	155	50.1	W	20
st.25	Niskin Sampler	71	49.5	N	155	50.1	W	30
st.25	Niskin Sampler	71	49.5	N	155	50.1	W	40
st.25	Niskin Sampler	71	49.5	N	155	50.1	W	50
st.25	Niskin Sampler	71	49.5	N	155	50.1	W	75
st.25	Niskin Sampler	71	49.5	N	155	50.1	W	21
st.26	Bucket sampling	71	48.06	N	155	22.98	W	0
st.26	Niskin Sampler	71	48.06	N	155	22.98	W	10
st.26	Niskin Sampler	71	48.06	N	155	22.98	W	20
st.26	Niskin Sampler	71	48.06	N	155	22.98	W	30
st.26	Niskin Sampler	71	48.06	N	155	22.98	W	40
st.26	Niskin Sampler	71	48.06	N	155	22.98	W	50
st.26	Niskin Sampler	71	48.06	N	155	22.98	W	75
st.26	Niskin Sampler	71	48.06	N	155	22.98	W	72
st.28	Bucket sampling	72	0	N	157	28.12	W	0
st.28	Niskin Sampler	72	0	N	157	28.12	W	30
st.28	Niskin Sampler	72	0	N	157	28.12	W	40
st.28	Niskin Sampler	72	0	N	157	28.12	W	50
st.28	Niskin Sampler	72	0	N	157	28.12	W	21
st.29	Bucket sampling	72	7.85	N	156	58.36	W	0

st.29	Niskin Sampler	72	7.85	N	156	58.36	W	30
st.29	Niskin Sampler	72	7.85	N	156	58.36	W	50
st.29	Niskin Sampler	72	7.85	N	156	58.36	W	100
st.29	Niskin Sampler	72	7.85	N	156	58.36	W	24
st.30	Bucket sampling	72	17.25	N	156	41.72	W	0
st.30	Niskin Sampler	72	17.25	N	156	41.72	W	30
st.30	Niskin Sampler	72	17.25	N	156	41.72	W	50
st.30	Niskin Sampler	72	17.25	N	156	41.72	W	100
st.30	Niskin Sampler	72	17.25	N	156	41.72	W	10
st.31	Bucket sampling	72	6.12	N	154	40	W	0
st.31	Niskin Sampler	72	6.12	N	154	40	W	30
st.31	Niskin Sampler	72	6.12	N	154	40	W	50
st.31	Niskin Sampler	72	6.12	N	154	40	W	100
st.31	Niskin Sampler	72	6.12	N	154	40	W	24
st.32	Bucket sampling	72	0	N	154	42	W	0
st.32	Niskin Sampler	72	0	N	154	42	W	30
st.32	Niskin Sampler	72	0	N	154	42	W	50
st.32	Niskin Sampler	72	0	N	154	42	W	100
st.32	Niskin Sampler	72	0	N	154	42	W	28
st.33	Bucket sampling	71	55	N	154	58.3	W	0
st.33	Niskin Sampler	71	55	N	154	58.3	W	30
st.33	Niskin Sampler	71	55	N	154	58.3	W	50
st.33	Niskin Sampler	71	55	N	154	58.3	W	100
st.33	Niskin Sampler	71	55	N	154	58.3	W	19
st.37	Bucket sampling	72	10.88	N	155	38.52	W	0
st.37	Niskin Sampler	72	10.88	N	155	38.52	W	30
st.37	Niskin Sampler	72	10.88	N	155	38.52	W	50
st.37	Niskin Sampler	72	10.88	N	155	38.52	W	100
st.37	Niskin Sampler	72	10.88	N	155	38.52	W	200
st.37	Niskin Sampler	72	10.88	N	155	38.52	W	300
st.37	Niskin Sampler	72	10.88	N	155	38.52	W	21
st.39	Bucket sampling	72	23.46	N	155	23.34	W	0
st.39	Niskin Sampler	72	23.46	N	155	23.34	W	30
st.39	Niskin Sampler	72	23.46	N	155	23.34	W	50
st.39	Niskin Sampler	72	23.46	N	155	23.34	W	100
st.39	Niskin Sampler	72	23.46	N	155	23.34	W	200
st.39	Niskin Sampler	72	23.46	N	155	23.34	W	300

st.39	Niskin Sampler	72	23.46	N	155	23.34	W	67
st.45	Bucket sampling	72	12.55	N	156	50.04	W	0
st.45	Niskin Sampler	72	12.55	N	156	50.04	W	10
st.45	Niskin Sampler	72	12.55	N	156	50.04	W	20
st.45	Niskin Sampler	72	12.55	N	156	50.04	W	30
st.45	Niskin Sampler	72	12.55	N	156	50.04	W	40
st.45	Niskin Sampler	72	12.55	N	156	50.04	W	50
st.45	Niskin Sampler	72	12.55	N	156	50.04	W	75
st.45	Niskin Sampler	72	12.55	N	156	50.04	W	100
st.46	Bucket sampling	72	3.93	N	157	13.24	W	0
st.46	Niskin Sampler	72	3.93	N	157	13.24	W	10
st.46	Niskin Sampler	72	3.93	N	157	13.24	W	20
st.46	Niskin Sampler	72	3.93	N	157	13.24	W	30
st.46	Niskin Sampler	72	3.93	N	157	13.24	W	40
st.46	Niskin Sampler	72	3.93	N	157	13.24	W	50
st.46	Niskin Sampler	72	3.93	N	157	13.24	W	75
st.47	Bucket sampling	71	57	N	158	0	W	0
st.47	Niskin Sampler	71	57	N	158	0	W	30
st.47	Niskin Sampler	71	57	N	158	0	W	50
st.47	Niskin Sampler	71	57	N	158	0	W	17
st.53_4	Bucket sampling	72	20.46	N	155	23.34	W	0
st.53_4	Niskin Sampler	72	20.46	N	155	23.34	W	30
st.53_4	Niskin Sampler	72	20.46	N	155	23.34	W	50
st.53_4	Niskin Sampler	72	20.46	N	155	23.34	W	100
st.53_4	Niskin Sampler	72	20.46	N	155	23.34	W	200
st.53_4	Niskin Sampler	72	20.46	N	155	23.34	W	19
st53_12	Bucket sampling	72	20.46	N	155	23.34	W	0
st53_12	Niskin Sampler	72	20.46	N	155	23.34	W	30
st53_12	Niskin Sampler	72	20.46	N	155	23.34	W	50
st53_12	Niskin Sampler	72	20.46	N	155	23.34	W	100
st53_12	Niskin Sampler	72	20.46	N	155	23.34	W	200
st53_12	Niskin Sampler	72	20.46	N	155	23.34	W	20
st.54	Bucket sampling	72	28.283 3	N	155	23.3667	W	0
st.54	Niskin Sampler	72	28.283 3	N	155	23.3667	W	30
st.54	Niskin Sampler	72	28.283 3	N	155	23.3667	W	50
st.54	Niskin Sampler	72	28.283 3	N	155	23.3667	W	100

st.54	Niskin Sampler	72	28.283 3	N	155	23.3667	W	200
st.54	Niskin Sampler	72	28.283 3	N	155	23.3667	W	19
st.55_1	Bucket sampling	72	22.787 7	N	155	58.7535	W	0
st.55_1	Niskin Sampler	72	22.787 7	N	155	58.7535	W	30
st.55_1	Niskin Sampler	72	22.787 7	N	155	58.7535	W	50
st.55_1	Niskin Sampler	72	22.787 7	N	155	58.7535	W	100
st.55_1	Niskin Sampler	72	22.787 7	N	155	58.7535	W	200
st.55_1	Niskin Sampler	72	22.787 7	N	155	58.7535	W	30
st.56_8	Bucket sampling	72	16.787 7	N	155	58.7535	W	0
st.56_8	Niskin Sampler	72	16.787 7	N	155	58.7535	W	30
st.56_8	Niskin Sampler	72	16.787 7	N	155	58.7535	W	50
st.56_8	Niskin Sampler	72	16.787 7	N	155	58.7535	W	100
st.56_8	Niskin Sampler	72	16.787 7	N	155	58.7535	W	200
st.56_8	Niskin Sampler	72	16.787 7	N	155	58.7535	W	18
st.56_10	Bucket sampling	72	16.787 7	N	155	58.7535	W	0
st.56_10	Niskin Sampler	72	16.787 7	N	155	58.7535	W	30
st.56_10	Niskin Sampler	72	16.787 7	N	155	58.7535	W	50
st.56_10	Niskin Sampler	72	16.787 7	N	155	58.7535	W	100
st.56_10	Niskin Sampler	72	16.787 7	N	155	58.7535	W	200
st.56_10	Niskin Sampler	72	16.787 7	N	155	58.7535	W	19
st.56_16	Bucket sampling	72	16.787 7	N	155	58.7535	W	0
st.56_16	Niskin Sampler	72	16.787 7	N	155	58.7535	W	30
st.56_16	Niskin Sampler	72	16.787 7	N	155	58.7535	W	50
st.56_16	Niskin Sampler	72	16.787 7	N	155	58.7535	W	100
st.56_16	Niskin Sampler	72	16.787 7	N	155	58.7535	W	200
st.56_16	Niskin Sampler	72	16.787 7	N	155	58.7535	W	18
st.62	Bucket sampling	71	50	N	153	50	W	0
st.62	Niskin Sampler	71	50	N	153	50	W	30
st.62	Niskin Sampler	71	50	N	153	50	W	50

st.62	Niskin Sampler	71	50	N	153	50	W	100
st.62	Niskin Sampler	71	50	N	153	50	W	26
st.82	Bucket sampling	73	9.5	N	162	18.71	W	0
st.82	Niskin Sampler	73	9.5	N	162	18.71	W	30
st.82	Niskin Sampler	73	9.5	N	162	18.71	W	50
st.82	Niskin Sampler	73	9.5	N	162	18.71	W	100
st.82	Niskin Sampler	73	9.5	N	162	18.71	W	15
st.94	Bucket sampling	73	28.38	N	160	8.33	W	0
st.94	Niskin Sampler	73	28.38	N	160	8.33	W	10
st.94	Niskin Sampler	73	28.38	N	160	8.33	W	30
st.94	Niskin Sampler	73	28.38	N	160	8.33	W	50
st.94	Niskin Sampler	73	28.38	N	160	8.33	W	100
st.94	Niskin Sampler	73	28.38	N	160	8.33	W	32
st.106	Bucket sampling	68	0	N	168	45	W	0
st.106	Niskin Sampler	68	0	N	168	45	W	5
st.106	Niskin Sampler	68	0	N	168	45	W	10
st.106	Niskin Sampler	68	0	N	168	45	W	20
st.106	Niskin Sampler	68	0	N	168	45	W	30
st.106	Niskin Sampler	68	0	N	168	45	W	40
st.107	Bucket sampling	68	30	N	168	45	W	0
st.107	Niskin Sampler	68	30	N	168	45	W	5
st.107	Niskin Sampler	68	30	N	168	45	W	10
st.107	Niskin Sampler	68	30	N	168	45	W	20
st.107	Niskin Sampler	68	30	N	168	45	W	30
st.107	Niskin Sampler	68	30	N	168	45	W	40

(6) Preliminary results

From the FRRF measurements, rETR value was calculated (which reflect photosynthesis activity). In the st.7 shows higher rETR and Fv/Fm value compare to another station.

(7) Data archives

These data obtained in this cruise will be submitted to the Data Management Group of JAMSTEC, and will be opened to the public via “Data Research System for Whole Cruise Information in JAMSTEC (DARWIN)” in JAMSTEC web site.

<<http://www.godac.jamstec.go.jp/darwin/e>>

4.17. Plankton photographs

(1) Personnel

Shigeto Nishino	(JAMSTEC): Principal investigator
Tomohide Noguchi	(MWJ)

(2) Objective

To obtain images and components of planktons, photographs were taken by a camera with a microscope.

(3) Parameter

Plankton photographs

(4) Instruments and methods

Intake water or water from Niskin bottles or bucket, which was filtered through a funnel with 200 μm mesh, was collected in a 1L plastic bottle. The water in the bottle was condensed to be 10 mL through a filter with a pore size of 20 μm . The condensed water was pumped to a cell and planktons with sizes of 20 – 200 μm in the condensed water flowing in a cell was taken by a camera with a microscope (\times 400).

(5) Observation log

The sampling list is summarized in Table 4.17-1.

(6) Data archives

These data obtained in this cruise will be submitted to the Data Management Group of JAMSTEC, and will be opened to the public via “Data Research System for Whole Cruise Information in JAMSTEC (DARWIN)” in JAMSTEC web site.

Table 4.17-1: Sampling list for plankton photographs

On board ID	Sampling Method	Condensation rate	Date Collected				Latitude			Longitude			Depth [m]
			YYYY	MM	DD	UTC	Deg.	Min.	N/S	Deg.	Min.	E/W	
MR15-03_St001_FlowCAM_#249-090039-P001	Niskin	100	2015	09	06	7:15	65	45.69	N	168	45.18	W	0
MR15-03_St001_FlowCAM_#249-101130-P002	Niskin	100	2015	09	06	7:15	65	45.69	N	168	45.18	W	Chl-aMax
MR15-03_St001_FlowCAM_#249-111817-P003	Niskin	100	2015	09	06	7:15	65	45.69	N	168	45.18	W	B-10
MR15-03_TSG_FlowCAM_#249-215920-P004	Intake	100	2015	09	06	15:56	66	56.17	N	168	44.71	W	0
MR15-03_St006_FlowCAM_#250-144605-P005	Bucket	100	2015	09	06	2:11	67	59.91	N	168	46.64	W	0
MR15-03_St006_FlowCAM_#250-152127-P006	Niskin	100	2015	09	06	2:11	67	59.91	N	168	46.64	W	B-10
MR15-03_St006_FlowCAM_#250-162542-P007	Niskin	100	2015	09	06	2:11	67	59.91	N	168	46.64	W	Chl-aMax
MR15-03_TSG_FlowCAM_#250-181923-P008	Intake	100	2015	09	07	15:19	69	44.42	N	168	44.95	W	0
MR15-03_TSG_FlowCAM_#251-194831-P009	Intake	100	2015	09	08	14:35	71	13.23	N	161	18.40	W	0
MR15-03_TSG_FlowCAM_#252-192753-P010	Intake	100	2015	09	09	14:57	71	43.55	N	156	38.26	W	0
MR15-03_TSG_FlowCAM_#254-043450-P011	Intake	100	2015	09	10	15:18	71	44.75	N	155	12.59	W	0
MR15-03_TSG_FlowCAM_#255-014407-P012	Intake	100	2015	09	11	15:59	71	36.67	N	154	51.74	W	0
MR15-03_TSG_FlowCAM_#256-002511-P013	Intake	100	2015	09	12	14:37	72	07.00	N	157	01.36	W	0
MR15-03_TSG_FlowCAM_#256-151251-P014	Intake	100	2015	09	13	14:39	72	06.40	N	154	40.95	W	0
MR15-03_TSG_FlowCAM_#257-151148-P015	Intake	100	2015	09	14	14:29	72	12.07	N	155	43.34	W	0
MR15-03_St039_FlowCAM_#258-004033-P016	Bucket	100	2015	09	14	1:28	72	23.48	N	155	24.15	W	0
MR15-03_St039_FlowCAM_#258-153950-P017	Niskin	100	2015	09	14	1:28	72	23.48	N	155	24.15	W	Chl-aMax
MR15-03_TSG_FlowCAM_#258-161848-P018	Intake	100	2015	09	15	14:12	72	12.51	N	156	50.81	W	0
MR15-03_TSG_FlowCAM_#259-152107-P019	Intake	100	2015	09	16	14:48	72	20.28	N	155	22.82	W	0
MR15-03_TSG_FlowCAM_#260-174032-P020	Intake	100	2015	09	17	15:28	72	20.57	N	155	22.96	W	0
MR15-03_TSG_FlowCAM_#261-163937-P021	Intake	100	2015	09	18	15:09	72	27.86	N	155	26.30	W	0
MR15-03_TSG_FlowCAM_#262-153900-P022	Intake	100	2015	09	19	15:07	72	21.41	N	155	55.10	W	0
MR15-03_St055_FlowCAM_#262-215347-P023	Bucket	100	2015	09	19	20:50	72	22.93	N	155	59.76	W	0
MR15-03_St055_FlowCAM_#262-222807-P024	Niskin	100	2015	09	19	20:50	72	22.93	N	155	59.76	W	Chl-aMax
MR15-03_TSG_FlowCAM_#263-155440-P025	Intake	100	2015	09	20	15:23	72	16.79	N	155	58.03	W	0
MR15-03_TSG_FlowCAM_#264-162416-P026	Intake	100	2015	09	21	15:14	72	17.10	N	155	58.78	W	0
MR15-03_TSG_FlowCAM_#265-185117-P027	Intake	100	2015	09	22	14:59	72	01.28	N	153	51.26	W	0
MR15-03_TSG_FlowCAM_#266-194647-P028	Intake	100	2015	09	23	15:28	72	14.17	N	156	21.98	W	0
MR15-03_TSG_FlowCAM_#268-020306-P029	Intake	100	2015	09	24	15:45	72	41.02	N	159	24.34	W	0
MR15-03_TSG_FlowCAM_#269-014832-P030	Intake	100	2015	09	25	15:57	73	18.39	N	160	47.06	W	0
MR15-03_TSG_FlowCAM_#269-210734-P031	Intake	100	2015	09	26	16:16	73	18.38	N	160	47.05	W	0
MR15-03_St085_FlowCAM_#269-214235-P032	Bucket	100	2015	09	26	19:52	73	18.61	N	160	45.60	W	0
MR15-03_St085_FlowCAM_#269-221433-P033	Niskin	100	2015	09	26	19:52	73	18.61	N	160	45.60	W	Chl-aMax
MR15-03_TSG_FlowCAM_#270-164644-P034	Intake	100	2015	09	27	16:27	73	29.26	N	162	14.72	W	0

MR15-03_TSG_FlowCAM_#272-035322-P035	Intake	100	2015	09	28	16:26	74	15.77	N	166	27.90	W	0
MR15-03_TSG_FlowCAM_#272-171437-P036	Intake	100	2015	09	29	16:16	72	31.85	N	168	44.51	W	0
MR15-03_TSG_FlowCAM_#273-175559-P037	Intake	100	2015	09	30	16:43	69	15.92	N	168	47.50	W	0
MR15-03_TSG_FlowCAM_#275-200155-P038	Intake	100	2015	10	01	16:59	68	02.78	N	168	49.99	W	0
MR15-03_TSG_FlowCAM_#275-203519-P039	Intake	100	2015	10	02	16:57	68	03.98	N	168	51.64	W	0
MR15-03_TSG_FlowCAM_#276-192841-P040	Intake	100	2015	10	03	16:54	66	00.60	N	168	44.55	W	0
MR15-03_TSG_FlowCAM_#277-182452-P041	Intake	100	2015	10	04	6:51	63	37.32	N	167	48.34	W	0
MR15-03_TSG_FlowCAM_#278-171812-P042	Intake	100	2015	10	05	5:46	59	33.76	N	167	52.14	W	0
MR15-03_TSG_FlowCAM_#283-173816-P043	Intake	100	2015	10	10	16:55	54	00.62	N	172	15.77	W	0
MR15-03_TSG_FlowCAM_#284-182730-P044	Intake	100	2015	10	11	5:40	53	51.99	N	175	44.79	W	0
MR15-03_TSG_FlowCAM_#285-192446-P045	Intake	100	2015	10	12	6:05	53	30.92	N	176	12.05	E	0
MR15-03_TSG_FlowCAM_#286-203925-P046	Intake	100	2015	10	13	6:39	51	13.65	N	170	22.66	E	0
MR15-03_TSG_FlowCAM_#287-175744-P047	Intake	100	2015	10	14	6:42	47	40.07	N	167	46.44	E	0
MR15-03_TSG_FlowCAM_#288-213951-P048	Intake	100	2015	10	15	7:29	45	47.25	N	166	13.98	E	0
MR15-03_TSG_FlowCAM_#289-212232-P049	Intake	100	2015	10	16	7:46	44	37.09	N	162	46.75	E	0
MR15-03_TSG_FlowCAM_#290-205610-P050	Intake	100	2015	10	17	7:16	43	10.39	N	158	30.65	E	0
MR15-03_TSG_FlowCAM_#291-215311-P051	Intake	100	2015	10	18	7:44	41	05.77	N	152	48.82	E	0

4.18. Sea water sampling for DNA sequence based plankton composition analysis and isolation of algal strains

(1) Personnel

Fumihito Itoh (JAMSTEC / University of Tsukuba)

Naomi Harada (JAMSTEC): PI

(2) Objectives

1. Understanding of phytoplankton and microzooplankton DNAseq based community composition.

- Water sampling for phytoplankton community composition.

2. For phytoplankton culture, isolation of algal strains were performed in order to investigate the influence of drastic climate change of Arctic region on their physiological responses, and analyze phytoplankton produced organic compounds.

(3) Parameters

18SrRNA or 16SrRNA sequence based plankton composition analysis.

Isolation of algal strains.

(4) Instruments and methods

Water samples were taken by bucket and CTD niskin sampler. Water samples for DNA analysis were filtered on mixed cellulose ester membrane filter (pore size 0.45µm, 47mm or 25mm diameter), and the filter was preserved in DNA storage solution at room temperature which contained 0.25M EDTA (pH 8.0), 20%DMSO, and NaCl (saturated). After the cruise, these samples were preserved in freezer (-20°C). Water samples for establishment of algal strains were diluted with L1 medium (Table 4.18-1) and incubated in 25ml conical flask under fluorescent light (light: dark=16:8) at 4°C.

Table 4.18-1: Compositions of media

L1 medium	
	Concentration
NaNO ₃ (anhydrous)	882 µM
NaH ₂ PO ₄ ·H ₂ O	36.2 µM
Na ₂ SiO ₃ ·9H ₂ O	106 µM
Thiamin HCl (VB1)	296 nM
Biotin (VH)	2.05 nM
Cyanocobalamine (VB12)	0.369 nM
Na ₂ EDTA·2H ₂ O	11.7 µM
FeCl ₃ ·6H ₂ O	11.7 µM

MnCl ₂ •4H ₂ O	909 nM
ZnSO ₄ •7H ₂ O	80 nM
CoCl ₂ •6H ₂ O	50nM
CuSO ₄ •5H ₂ O	10nM
Na ₂ MoO ₄ •H ₂ O	82nM
H ₂ SeO ₃	10nM
NiSO ₄ •6H ₂ O	10nM
Na ₃ VO ₄	10nM
K ₂ CrO ₄	10nM

(5) Station list

1)Station list for DNAseq based community composition analysis samples.

The sample list in Table 4.18-2

2)Station list for phytoplankton culture

The sample list in Table 4.18-3

Table 4.18-2: Station list for filter samples for DNA analysis.

Station No.	Sample volume	Sampling Method	Latitude			Longitude			Depth [m]
			Deg.	Min.	N/S	Deg.	Min.	E/W	
st.01	1L	Bucket sampling	65	45.8	N	168	45.6	W	0
st.01	1L	Niskin Sampler	65	45.8	N	168	45.6	W	10
st.01	1L	Niskin Sampler	65	45.8	N	168	45.6	W	20
st.01	1L	Niskin Sampler	65	45.8	N	168	45.6	W	30
st.01	1L	Niskin Sampler	65	45.8	N	168	45.6	W	40
st.02	1L	Bucket sampling	66	0	N	168	45	W	0
st.02	1L	Niskin Sampler	66	0	N	168	45	W	10
st.02	1L	Niskin Sampler	66	0	N	168	45	W	20
st.02	1L	Niskin Sampler	66	0	N	168	45	W	30
st.02	1L	Niskin Sampler	66	0	N	168	45	W	40
st.03	1L	Bucket sampling	66	30	N	168	45	W	0
st.03	1L	Niskin Sampler	66	30	N	168	45	W	10
st.03	1L	Niskin Sampler	66	30	N	168	45	W	20
st.03	1L	Niskin Sampler	66	30	N	168	45	W	30
st.03	1L	Niskin Sampler	66	30	N	168	45	W	40
st.04	1L	Bucket sampling	67	0	N	168	45	W	0

st.04	1L	Niskin Sampler	67	0	N	168	45	W	10
st.04	1L	Niskin Sampler	67	0	N	168	45	W	20
st.04	1L	Niskin Sampler	67	0	N	168	45	W	30
st.05	1L	Bucket sampling	67	30	N	168	45	W	0
st.05	1L	Niskin Sampler	67	30	N	168	45	W	10
st.05	1L	Niskin Sampler	67	30	N	168	45	W	20
st.05	1L	Niskin Sampler	67	30	N	168	45	W	30
st.05	1L	Niskin Sampler	67	30	N	168	45	W	40
st.06	1L	Bucket sampling	68	0	N	168	45	W	0
st.06	1L	Niskin Sampler	68	0	N	168	45	W	10
st.06	1L	Niskin Sampler	68	0	N	168	45	W	20
st.06	1L	Niskin Sampler	68	0	N	168	45	W	30
st.06	1L	Niskin Sampler	68	0	N	168	45	W	40
st.07	1L	Bucket sampling	68	30	N	168	45	W	0
st.07	1L	Niskin Sampler	68	30	N	168	45	W	10
st.07	1L	Niskin Sampler	68	30	N	168	45	W	20
st.07	1L	Niskin Sampler	68	30	N	168	45	W	30
st.07	1L	Niskin Sampler	68	30	N	168	45	W	40
st.08	1L	Bucket sampling	69	0	N	168	45	W	0
st.08	1L	Niskin Sampler	69	0	N	168	45	W	10
st.08	1L	Niskin Sampler	69	0	N	168	45	W	20
st.08	1L	Niskin Sampler	69	0	N	168	45	W	30
st.08	1L	Niskin Sampler	69	0	N	168	45	W	40
st.09	1L	Bucket sampling	69	30	N	168	45	W	0
st.09	1L	Niskin Sampler	69	30	N	168	45	W	10
st.09	1L	Niskin Sampler	69	30	N	168	45	W	20
st.09	1L	Niskin Sampler	69	30	N	168	45	W	30
st.09	1L	Niskin Sampler	69	30	N	168	45	W	40
st.10	1L	Bucket sampling	70	0	N	168	45	W	0
st.10	1L	Niskin Sampler	70	0	N	168	45	W	10
st.10	1L	Niskin Sampler	70	0	N	168	45	W	20
st.10	1L	Niskin Sampler	70	0	N	168	45	W	30
st.11	1L	Bucket sampling	70	30	N	168	45	W	0
st.11	1L	Niskin Sampler	70	30	N	168	45	W	10
st.11	1L	Niskin Sampler	70	30	N	168	45	W	20
st.11	1L	Niskin Sampler	70	30	N	168	45	W	30
st.12	1L	Bucket sampling	71	0	N	168	45	W	0

st.12	1L	Niskin Sampler	71	0	N	168	45	W	10
st.12	1L	Niskin Sampler	71	0	N	168	45	W	20
st.12	1L	Niskin Sampler	71	0	N	168	45	W	30
st.13	1L	Bucket sampling	71	20	N	157	40	W	0
st.13	1L	Niskin Sampler	71	20	N	157	40	W	10
st.13	1L	Niskin Sampler	71	20	N	157	40	W	20
st.13	1L	Niskin Sampler	71	20	N	157	40	W	30
st.13	1L	Niskin Sampler	71	20	N	157	40	W	40
st.13	1L	Niskin Sampler	71	20	N	157	40	W	50
st.13	1L	Niskin Sampler	71	20	N	157	40	W	75
st.13	1L	Niskin Sampler	71	20	N	157	40	W	8
st.14	1L	Bucket sampling	71	34.7	N	157	50.3	W	0
st.14	1L	Niskin Sampler	71	34.7	N	157	50.3	W	10
st.14	1L	Niskin Sampler	71	34.7	N	157	50.3	W	20
st.14	1L	Niskin Sampler	71	34.7	N	157	50.3	W	30
st.14	1L	Niskin Sampler	71	34.7	N	157	50.3	W	40
st.14	1L	Niskin Sampler	71	34.7	N	157	50.3	W	50
st.14	1L	Niskin Sampler	71	34.7	N	157	50.3	W	51
st.15	1L	Bucket sampling	71	24.8	N	157	29.9	W	0
st.15	1L	Niskin Sampler	71	24.8	N	157	29.9	W	10
st.15	1L	Niskin Sampler	71	24.8	N	157	29.9	W	20
st.15	1L	Niskin Sampler	71	24.8	N	157	29.9	W	30
st.15	1L	Niskin Sampler	71	24.8	N	157	29.9	W	40
st.15	1L	Niskin Sampler	71	24.8	N	157	29.9	W	50
st.15	1L	Niskin Sampler	71	24.8	N	157	29.9	W	75
st.15	1L	Niskin Sampler	71	24.8	N	157	29.9	W	115
st.15	1L	Niskin Sampler	71	24.8	N	157	29.9	W	14
st.16	1L	Bucket sampling	71	14.8	N	157	9.9	W	0
st.16	1L	Niskin Sampler	71	14.8	N	157	9.9	W	10
st.16	1L	Niskin Sampler	71	14.8	N	157	9.9	W	20
st.16	1L	Niskin Sampler	71	14.8	N	157	9.9	W	30
st.16	1L	Niskin Sampler	71	14.8	N	157	9.9	W	35
st.22	1L	Bucket sampling	71	35.52	N	154	48.78	W	0
st.22	1L	Niskin Sampler	71	35.52	N	154	48.78	W	10
st.22	1L	Niskin Sampler	71	35.52	N	154	48.78	W	20
st.22	1L	Niskin Sampler	71	35.52	N	154	48.78	W	30
st.22	1L	Niskin Sampler	71	35.52	N	154	48.78	W	29

st.23	1L	Bucket sampling	71	44.1	N	155	11.88	W	0
st.23	1L	Niskin Sampler	71	44.1	N	155	11.88	W	10
st.23	1L	Niskin Sampler	71	44.1	N	155	11.88	W	20
st.23	1L	Niskin Sampler	71	44.1	N	155	11.88	W	30
st.23	1L	Niskin Sampler	71	44.1	N	155	11.88	W	75
st.23	1L	Niskin Sampler	71	44.1	N	155	11.88	W	125
st.23	1L	Niskin Sampler	71	44.1	N	155	11.88	W	200
st.23	1L	Niskin Sampler	71	44.1	N	155	11.88	W	24
st.24	1L	Bucket sampling	71	52.62	N	156	2.28	W	0
st.24	1L	Niskin Sampler	71	52.62	N	156	2.28	W	10
st.24	1L	Niskin Sampler	71	52.62	N	156	2.28	W	20
st.24	1L	Niskin Sampler	71	52.62	N	156	2.28	W	30
st.24	1L	Niskin Sampler	71	52.62	N	156	2.28	W	40
st.24	1L	Niskin Sampler	71	52.62	N	156	2.28	W	50
st.24	1L	Niskin Sampler	71	52.62	N	156	2.28	W	35
st.25	1L	Bucket sampling	71	49.5	N	155	50.1	W	0
st.25	1L	Niskin Sampler	71	49.5	N	155	50.1	W	10
st.25	1L	Niskin Sampler	71	49.5	N	155	50.1	W	20
st.25	1L	Niskin Sampler	71	49.5	N	155	50.1	W	30
st.25	1L	Niskin Sampler	71	49.5	N	155	50.1	W	40
st.25	1L	Niskin Sampler	71	49.5	N	155	50.1	W	50
st.25	1L	Niskin Sampler	71	49.5	N	155	50.1	W	75
st.25	1L	Niskin Sampler	71	49.5	N	155	50.1	W	21
st.26	1L	Bucket sampling	71	48.06	N	155	22.98	W	0
st.26	1L	Niskin Sampler	71	48.06	N	155	22.98	W	10
st.26	1L	Niskin Sampler	71	48.06	N	155	22.98	W	20
st.26	1L	Niskin Sampler	71	48.06	N	155	22.98	W	30
st.26	1L	Niskin Sampler	71	48.06	N	155	22.98	W	40
st.26	1L	Niskin Sampler	71	48.06	N	155	22.98	W	50
st.26	1L	Niskin Sampler	71	48.06	N	155	22.98	W	75
st.26	1L	Niskin Sampler	71	48.06	N	155	22.98	W	72
st.27	1L	Bucket sampling	71	40.02	N	155	0.72	W	0
st.27	1L	Niskin Sampler	71	40.02	N	155	0.72	W	10
st.27	1L	Niskin Sampler	71	40.02	N	155	0.72	W	20
st.27	1L	Niskin Sampler	71	40.02	N	155	0.72	W	30
st.27	1L	Niskin Sampler	71	40.02	N	155	0.72	W	40
st.27	1L	Niskin Sampler	71	40.02	N	155	0.72	W	50

st.27	1L	Niskin Sampler	71	40.02	N	155	0.72	W	75
st.27	1L	Niskin Sampler	71	40.02	N	155	0.72	W	57
st.28	1L	Bucket sampling	72	0	N	157	28.12	W	0
st.28	1L	Niskin Sampler	72	0	N	157	28.12	W	30
st.28	1L	Niskin Sampler	72	0	N	157	28.12	W	40
st.28	1L	Niskin Sampler	72	0	N	157	28.12	W	50
st.28	1L	Niskin Sampler	72	0	N	157	28.12	W	21
st.29	1L	Bucket sampling	72	7.85	N	156	58.36	W	0
st.29	1L	Niskin Sampler	72	7.85	N	156	58.36	W	30
st.29	1L	Niskin Sampler	72	7.85	N	156	58.36	W	50
st.29	1L	Niskin Sampler	72	7.85	N	156	58.36	W	100
st.29	1L	Niskin Sampler	72	7.85	N	156	58.36	W	24
st.30	1L	Bucket sampling	72	17.25	N	156	41.72	W	0
st.30	1L	Niskin Sampler	72	17.25	N	156	41.72	W	30
st.30	1L	Niskin Sampler	72	17.25	N	156	41.72	W	50
st.30	1L	Niskin Sampler	72	17.25	N	156	41.72	W	100
st.30	1L	Niskin Sampler	72	17.25	N	156	41.72	W	10
st.31	1L	Bucket sampling	72	6.12	N	154	40	W	0
st.31	1L	Niskin Sampler	72	6.12	N	154	40	W	30
st.31	1L	Niskin Sampler	72	6.12	N	154	40	W	50
st.31	1L	Niskin Sampler	72	6.12	N	154	40	W	100
st.31	1L	Niskin Sampler	72	6.12	N	154	40	W	24
st.32	1L	Bucket sampling	72	0	N	154	42	W	0
st.32	1L	Niskin Sampler	72	0	N	154	42	W	30
st.32	1L	Niskin Sampler	72	0	N	154	42	W	50
st.32	1L	Niskin Sampler	72	0	N	154	42	W	100
st.32	1L	Niskin Sampler	72	0	N	154	42	W	28
st.33	1L	Bucket sampling	71	55	N	154	58.3	W	0
st.33	1L	Niskin Sampler	71	55	N	154	58.3	W	30
st.33	1L	Niskin Sampler	71	55	N	154	58.3	W	50
st.33	1L	Niskin Sampler	71	55	N	154	58.3	W	100
st.33	1L	Niskin Sampler	71	55	N	154	58.3	W	19
st.37	1L	Bucket sampling	72	10.88	N	155	38.52	W	0
st.37	1L	Niskin Sampler	72	10.88	N	155	38.52	W	30
st.37	1L	Niskin Sampler	72	10.88	N	155	38.52	W	50
st.37	1L	Niskin Sampler	72	10.88	N	155	38.52	W	100
st.37	1L	Niskin Sampler	72	10.88	N	155	38.52	W	200

st.37	1L	Niskin Sampler	72	10.88	N	155	38.52	W	300
st.37	1L	Niskin Sampler	72	10.88	N	155	38.52	W	21
st.39	1L	Bucket sampling	72	23.46	N	155	23.34	W	0
st.39	1L	Niskin Sampler	72	23.46	N	155	23.34	W	30
st.39	1L	Niskin Sampler	72	23.46	N	155	23.34	W	50
st.39	1L	Niskin Sampler	72	23.46	N	155	23.34	W	100
st.39	1L	Niskin Sampler	72	23.46	N	155	23.34	W	200
st.39	1L	Niskin Sampler	72	23.46	N	155	23.34	W	300
st.39	1L	Niskin Sampler	72	23.46	N	155	23.34	W	67
st.47	1L	Bucket sampling	71	57	N	158	0	W	0
st.47	1L	Niskin Sampler	71	57	N	158	0	W	30
st.47	1L	Niskin Sampler	71	57	N	158	0	W	50
st.47	1L	Niskin Sampler	71	57	N	158	0	W	17
st.53_4	1L	Bucket sampling	72	20.46	N	155	23.34	W	0
st.53_4	1L	Niskin Sampler	72	20.46	N	155	23.34	W	30
st.53_4	1L	Niskin Sampler	72	20.46	N	155	23.34	W	50
st.53_4	1L	Niskin Sampler	72	20.46	N	155	23.34	W	100
st.53_4	1L	Niskin Sampler	72	20.46	N	155	23.34	W	200
st.53_4	1L	Niskin Sampler	72	20.46	N	155	23.34	W	19
st53_12	1L	Bucket sampling	72	20.46	N	155	23.34	W	0
st53_12	1L	Niskin Sampler	72	20.46	N	155	23.34	W	30
st53_12	1L	Niskin Sampler	72	20.46	N	155	23.34	W	50
st53_12	1L	Niskin Sampler	72	20.46	N	155	23.34	W	100
st53_12	1L	Niskin Sampler	72	20.46	N	155	23.34	W	200
st53_12	1L	Niskin Sampler	72	20.46	N	155	23.34	W	20
st.54	1L	Bucket sampling	72	28.2833	N	155	23.3667	W	0
st.54	1L	Niskin Sampler	72	28.2833	N	155	23.3667	W	30
st.54	1L	Niskin Sampler	72	28.2833	N	155	23.3667	W	50
st.54	1L	Niskin Sampler	72	28.2833	N	155	23.3667	W	100
st.54	1L	Niskin Sampler	72	28.2833	N	155	23.3667	W	200
st.54	1L	Niskin Sampler	72	28.2833	N	155	23.3667	W	19
st.55_1	1L	Bucket sampling	72	22.7877	N	155	58.7535	W	0
st.55_1	1L	Niskin Sampler	72	22.7877	N	155	58.7535	W	30
st.55_1	1L	Niskin Sampler	72	22.7877	N	155	58.7535	W	50
st.55_1	1L	Niskin Sampler	72	22.7877	N	155	58.7535	W	100
st.55_1	1L	Niskin Sampler	72	22.7877	N	155	58.7535	W	200
st.55_1	1L	Niskin Sampler	72	22.7877	N	155	58.7535	W	30

st.56_8	1L	Bucket sampling	72	16.7877	N	155	58.7535	W	0
st.56_8	1L	Niskin Sampler	72	16.7877	N	155	58.7535	W	30
st.56_8	1L	Niskin Sampler	72	16.7877	N	155	58.7535	W	50
st.56_8	1L	Niskin Sampler	72	16.7877	N	155	58.7535	W	100
st.56_8	1L	Niskin Sampler	72	16.7877	N	155	58.7535	W	200
st.56_8	1L	Niskin Sampler	72	16.7877	N	155	58.7535	W	18
st.56_10	1L	Bucket sampling	72	16.7877	N	155	58.7535	W	0
st.56_10	1L	Niskin Sampler	72	16.7877	N	155	58.7535	W	30
st.56_10	1L	Niskin Sampler	72	16.7877	N	155	58.7535	W	50
st.56_10	1L	Niskin Sampler	72	16.7877	N	155	58.7535	W	100
st.56_10	1L	Niskin Sampler	72	16.7877	N	155	58.7535	W	200
st.56_10	1L	Niskin Sampler	72	16.7877	N	155	58.7535	W	19
st.56_16	1L	Bucket sampling	72	16.7877	N	155	58.7535	W	0
st.56_16	1L	Niskin Sampler	72	16.7877	N	155	58.7535	W	30
st.56_16	1L	Niskin Sampler	72	16.7877	N	155	58.7535	W	50
st.56_16	1L	Niskin Sampler	72	16.7877	N	155	58.7535	W	100
st.56_16	1L	Niskin Sampler	72	16.7877	N	155	58.7535	W	200
st.56_16	1L	Niskin Sampler	72	16.7877	N	155	58.7535	W	18
st.62	1L	Bucket sampling	71	50	N	153	50	W	0
st.62	1L	Niskin Sampler	71	50	N	153	50	W	30
st.62	1L	Niskin Sampler	71	50	N	153	50	W	50
st.62	1L	Niskin Sampler	71	50	N	153	50	W	100
st.62	1L	Niskin Sampler	71	50	N	153	50	W	26
st.63	1L	Bucket sampling	72	22.2	N	155	31.2	W	0
st.63	1L	Niskin Sampler	72	22.2	N	155	31.2	W	30
st.63	1L	Niskin Sampler	72	22.2	N	155	31.2	W	50
st.63	1L	Niskin Sampler	72	22.2	N	155	31.2	W	100
st.63	1L	Niskin Sampler	72	22.2	N	155	31.2	W	60
st.64	1L	Bucket sampling	72	15.8998	N	155	57.5403	W	0
st.64	1L	Niskin Sampler	72	15.8998	N	155	57.5403	W	30
st.64	1L	Niskin Sampler	72	15.8998	N	155	57.5403	W	50
st.64	1L	Niskin Sampler	72	15.8998	N	155	57.5403	W	100
st.64	1L	Niskin Sampler	72	15.8998	N	155	57.5403	W	36
st.65	1L	Bucket sampling	72	11.6984	N	156	15.1102	W	0
st.65	1L	Niskin Sampler	72	11.6984	N	156	15.1102	W	30
st.65	1L	Niskin Sampler	72	11.6984	N	156	15.1102	W	50
st.65	1L	Niskin Sampler	72	11.6984	N	156	15.1102	W	100

st.65	1L	Niskin Sampler	72	11.6984	N	156	15.1102	W	18
st.66	1L	Bucket sampling	72	15.8991	N	156	24.485	W	0
st.66	1L	Niskin Sampler	72	15.8991	N	156	24.485	W	30
st.66	1L	Niskin Sampler	72	15.8991	N	156	24.485	W	50
st.66	1L	Niskin Sampler	72	15.8991	N	156	24.485	W	100
st.66	1L	Niskin Sampler	72	15.8991	N	156	24.485	W	35
st.67	1L	Bucket sampling	72	10	N	155	31.2	W	0
st.67	1L	Niskin Sampler	72	10	N	155	31.2	W	30
st.67	1L	Niskin Sampler	72	10	N	155	31.2	W	50
st.67	1L	Niskin Sampler	72	10	N	155	31.2	W	100
st.67	1L	Niskin Sampler	72	10	N	155	31.2	W	13
st.68	1L	Bucket sampling	72	10.08	N	156	12.6	W	0
st.68	1L	Niskin Sampler	72	10.08	N	156	12.6	W	30
st.68	1L	Niskin Sampler	72	10.08	N	156	12.6	W	50
st.68	1L	Niskin Sampler	72	10.08	N	156	12.6	W	100
st.68	1L	Niskin Sampler	72	10.08	N	156	12.6	W	39
st.69	1L	Bucket sampling	72	10.08	N	155	52.86	W	0
st.69	1L	Niskin Sampler	72	10.08	N	155	52.86	W	30
st.69	1L	Niskin Sampler	72	10.08	N	155	52.86	W	50
st.69	1L	Niskin Sampler	72	10.08	N	155	52.86	W	100
st.69	1L	Niskin Sampler	72	10.08	N	155	52.86	W	24
st.70	1L	Bucket sampling	72	10.02	N	156	42	W	0
st.70	1L	Niskin Sampler	72	10.02	N	156	42	W	30
st.70	1L	Niskin Sampler	72	10.02	N	156	42	W	50
st.70	1L	Niskin Sampler	72	10.02	N	156	42	W	100
st.70	1L	Niskin Sampler	72	10.02	N	156	42	W	31
st.75	1L	Bucket sampling	73	12.47	N	157	49.6	W	0
st.75	1L	Niskin Sampler	73	12.47	N	157	49.6	W	30
st.75	1L	Niskin Sampler	73	12.47	N	157	49.6	W	50
st.75	1L	Niskin Sampler	73	12.47	N	157	49.6	W	100
st.75	1L	Niskin Sampler	73	12.47	N	157	49.6	W	44
st.82	1L	Bucket sampling	73	9.5	N	162	18.71	W	0
st.82	1L	Niskin Sampler	73	9.5	N	162	18.71	W	30
st.82	1L	Niskin Sampler	73	9.5	N	162	18.71	W	50
st.82	1L	Niskin Sampler	73	9.5	N	162	18.71	W	100
st.82	1L	Niskin Sampler	73	9.5	N	162	18.71	W	15
st.84	1L	Bucket sampling	73	3.48	N	164	35.79	W	0

st.84	1L	Niskin Sampler	73	3.48	N	164	35.79	W	30
st.84	1L	Niskin Sampler	73	3.48	N	164	35.79	W	50
st.84	1L	Niskin Sampler	73	3.48	N	164	35.79	W	19
st.85	1L	Bucket sampling	73	17.87	N	160	48.11	W	0
st.85	1L	Niskin Sampler	73	17.87	N	160	48.11	W	20
st.85	1L	Niskin Sampler	73	17.87	N	160	48.11	W	30
st.85	1L	Niskin Sampler	73	17.87	N	160	48.11	W	50
st.85	1L	Niskin Sampler	73	17.87	N	160	48.11	W	75
st.85	1L	Niskin Sampler	73	17.87	N	160	48.11	W	100
st.85	1L	Niskin Sampler	73	17.87	N	160	48.11	W	13
st.94	1L	Bucket sampling	73	28.38	N	160	8.33	W	0
st.94	1L	Niskin Sampler	73	28.38	N	160	8.33	W	10
st.94	1L	Niskin Sampler	73	28.38	N	160	8.33	W	30
st.94	1L	Niskin Sampler	73	28.38	N	160	8.33	W	50
st.94	1L	Niskin Sampler	73	28.38	N	160	8.33	W	100
st.94	1L	Niskin Sampler	73	28.38	N	160	8.33	W	32
st.95	1L	Bucket sampling	73	34.11	N	165	56.07	W	0
st.95	1L	Niskin Sampler	73	34.11	N	165	56.07	W	10
st.95	1L	Niskin Sampler	73	34.11	N	165	56.07	W	30
st.95	1L	Niskin Sampler	73	34.11	N	165	56.07	W	50
st.95	1L	Niskin Sampler	73	34.11	N	165	56.07	W	16
st.96	1L	Bucket sampling	73	53.16	N	166	9.87	W	0
st.96	1L	Niskin Sampler	73	53.16	N	166	9.87	W	10
st.96	1L	Niskin Sampler	73	53.16	N	166	9.87	W	30
st.96	1L	Niskin Sampler	73	53.16	N	166	9.87	W	50
st.96	1L	Niskin Sampler	73	53.16	N	166	9.87	W	100
st.96	1L	Niskin Sampler	73	53.16	N	166	9.87	W	24
st.98	1L	Bucket sampling	74	30	N	166	40	W	0
st.98	1L	Niskin Sampler	74	30	N	166	40	W	10
st.98	1L	Niskin Sampler	74	30	N	166	40	W	30
st.98	1L	Niskin Sampler	74	30	N	166	40	W	50
st.98	1L	Niskin Sampler	74	30	N	166	40	W	100
st.98	1L	Niskin Sampler	74	30	N	166	40	W	26
st.99	1L	Bucket sampling	74	30	N	168	45	W	0
st.99	1L	Niskin Sampler	74	30	N	168	45	W	10
st.99	1L	Niskin Sampler	74	30	N	168	45	W	30
st.99	1L	Niskin Sampler	74	30	N	168	45	W	50

st.99	1L	Niskin Sampler	74	30	N	168	45	W	100
st.99	1L	Niskin Sampler	74	30	N	168	45	W	18
st.100	1L	Bucket sampling	74	0	N	168	45	W	0
st.100	1L	Niskin Sampler	74	0	N	168	45	W	10
st.100	1L	Niskin Sampler	74	0	N	168	45	W	30
st.100	1L	Niskin Sampler	74	0	N	168	45	W	50
st.100	1L	Niskin Sampler	74	0	N	168	45	W	100
st.100	1L	Niskin Sampler	74	0	N	168	45	W	16
st.101	1L	Bucket sampling	73	30	N	168	45	W	0
st.101	1L	Niskin Sampler	73	30	N	168	45	W	10
st.101	1L	Niskin Sampler	73	30	N	168	45	W	30
st.101	1L	Niskin Sampler	73	30	N	168	45	W	50
st.101	1L	Niskin Sampler	73	30	N	168	45	W	100
st.101	1L	Niskin Sampler	73	30	N	168	45	W	27
st.102	1L	Bucket sampling	72	0	N	168	45	W	0
st.102	1L	Niskin Sampler	72	0	N	168	45	W	10
st.102	1L	Niskin Sampler	72	0	N	168	45	W	20
st.102	1L	Niskin Sampler	72	0	N	168	45	W	30
st.102	1L	Niskin Sampler	72	0	N	168	45	W	40
st.102	1L	Niskin Sampler	72	0	N	168	45	W	23
st.103	1L	Bucket sampling	71	30	N	168	45	W	0
st.103	1L	Niskin Sampler	71	30	N	168	45	W	5
st.103	1L	Niskin Sampler	71	30	N	168	45	W	10
st.103	1L	Niskin Sampler	71	30	N	168	45	W	20
st.103	1L	Niskin Sampler	71	30	N	168	45	W	30
st.103	1L	Niskin Sampler	71	30	N	168	45	W	40
st.104	1L	Bucket sampling	71	0	N	168	45	W	0
st.104	1L	Niskin Sampler	71	0	N	168	45	W	5
st.104	1L	Niskin Sampler	71	0	N	168	45	W	10
st.104	1L	Niskin Sampler	71	0	N	168	45	W	20
st.104	1L	Niskin Sampler	71	0	N	168	45	W	30
st.104	1L	Niskin Sampler	71	0	N	168	45	W	40
st.105	1L	Bucket sampling	70	30	N	168	45	W	0
st.105	1L	Niskin Sampler	70	30	N	168	45	W	5
st.105	1L	Niskin Sampler	70	30	N	168	45	W	10
st.105	1L	Niskin Sampler	70	30	N	168	45	W	20
st.105	1L	Niskin Sampler	70	30	N	168	45	W	30

st.106	1L	Bucket sampling	68	0	N	168	45	W	0
st.106	1L	Niskin Sampler	68	0	N	168	45	W	5
st.106	1L	Niskin Sampler	68	0	N	168	45	W	10
st.106	1L	Niskin Sampler	68	0	N	168	45	W	20
st.106	1L	Niskin Sampler	68	0	N	168	45	W	30
st.106	1L	Niskin Sampler	68	0	N	168	45	W	40
st.107	1L	Bucket sampling	68	30	N	168	45	W	0
st.107	1L	Niskin Sampler	68	30	N	168	45	W	5
st.107	1L	Niskin Sampler	68	30	N	168	45	W	10
st.107	1L	Niskin Sampler	68	30	N	168	45	W	20
st.107	1L	Niskin Sampler	68	30	N	168	45	W	30
st.107	1L	Niskin Sampler	68	30	N	168	45	W	40
st.108	1L	Bucket sampling	67	0	N	168	45	W	0
st.108	1L	Niskin Sampler	67	0	N	168	45	W	5
st.108	1L	Niskin Sampler	67	0	N	168	45	W	10
st.108	1L	Niskin Sampler	67	0	N	168	45	W	20
st.108	1L	Niskin Sampler	67	0	N	168	45	W	30
st.109	1L	Bucket sampling	66	0	N	168	45	W	0
st.109	1L	Niskin Sampler	66	0	N	168	45	W	5
st.109	1L	Niskin Sampler	66	0	N	168	45	W	10
st.109	1L	Niskin Sampler	66	0	N	168	45	W	20
st.109	1L	Niskin Sampler	66	0	N	168	45	W	30
st.109	1L	Niskin Sampler	66	0	N	168	45	W	40

Table 4.18-3: Station list for seawater samples for isolation of algal strains.

Station No.	Sample volume	Sampling Method	Latitude			Longitude			Depth [m]
			Deg.	Min.	N/S	Deg.	Min.	E/W	
st.102	50ml	Niskin Sampler	72	0	N	168	45	W	0
st.102	50ml	Niskin Sampler	72	0	N	168	45	W	23
st.108	50ml	Bucket sampling	67	0	N	168	45	W	0
st.108	50ml	Niskin Sampler	67	0	N	168	45	W	35
st.99	50ml	Bucket sampling	74	30	N	168	45	W	0
st.99	50ml	Niskin Sampler	74	30	N	168	45	W	18
st.82	50ml	Bucket sampling	73	9.5	N	162	18.71	W	0
st.82	50ml	Niskin Sampler	73	9.5	N	162	18.71	W	15
st.94	50ml	Bucket sampling	73	28.38	N	160	8.33	W	0
st.94	50ml	Niskin Sampler	73	28.38	N	160	8.33	W	32

st.95	50ml	Bucket sampling	73	34.11	N	165	56.07	W	0
st.95	50ml	Niskin Sampler	73	34.11	N	165	56.07	W	16

(6) Preliminary results

The cells looked like haptophyta were investigated in the culture.

(7) Data archives

These data obtained in this cruise will be submitted to the Data Management Group of JAMSTEC, and will be opened to the public via “Data Research System for Whole Cruise Information in JAMSTEC (DARWIN)” in JAMSTEC web site.

<<http://www.godac.jamstec.go.jp/darwin/e>>

4.19. Phytoplankton incubation

(1) Personnel

Koji Sugie (JAMSTEC): Principal Investigator (PI)

Sohiko Kameyama (Hokkaido University)

Amane Fujiwara (JAMSTEC)

(2) Objective

On-deck incubation experiment was conducted to assess the synergistic impacts of ocean acidification, global warming and seawater fresh on phytoplankton community and biogeochemical cycling of bio-elements.

(3) Parameters

Chlorophyll-*a*, nutrients (NO₃, NO₂, NH₄, PO₄, Si(OH)₄), particulate organic carbon, particulate nitrogen, particulate phosphorus, particulate biogenic silica, dissolved organic carbon, dissolved organic nitrogen, dissolved organic phosphorus, DMS, dissolved and particulate DMSP, microscopic observation, flow cytometry, temperature, photosynthetic active radiation, dissolved inorganic carbon, total alkalinity

(4) Instruments and methods

Teflon® coated, Niskin-X sampling bottle attached to a CTD-CMS to collect seawater samples from a depth of 10 m for incubation. Seawater for the incubations were collected at 47°N 160°E. Eight treatments were prepared as follows:

- LT: Unamended control
- LT750: High CO₂ condition was achieved by adding CO₂ saturated filtered seawaters to the controls to make the seawater *p*CO₂ ca. 750 μatm.
- LTLS: Salinity decreased -1.5 relative to the controls by the addition of pure water.
- LTLS750: Salinity decreased -1.5 and *p*CO₂ increased ca. 750 μatm relative to the controls.
- HT: Temperature increased at 4°C relative to the controls
- HT750: Similar to LT750 but temperature increased.
- HTLS: Similar to LTLS but temperature increased.
- HTLS750: Similar to LTLS750 but temperature increased.

Seawater for the experiment was sieved by ca. 200 μm acid-cleaned

Teflon-mesh to eliminate mesozooplankton, and the prescreened seawater was poured into six acid washed 50 L polypropylene tanks to homogenize seawater samples. After Fe, nutrients, pure water, filtered seawater and/or CO₂ saturated filtered seawater were added and homogenized, seawater samples were dispensed into acid-washed polyethylene bags. To adjust *p*CO₂ in the high temperature series, alkalinity was manipulated by the addition of strong alkali (0.1 N NaOH, suprapur Merk). Bags were prepared in duplicate per treatment. Temperature of the incubation tanks were set at 3 (LT group) and 7°C (HT group). Incubations were lasted for 11 and 15 days in the HT group and LT group, respectively. Chlorophyll-*a* and nutrients were collected every day, and other parameters were collected periodically during the exponential growth and decline phase of the growth of phytoplankton.

(5) Observation log

September 14, 2015 71°44' N, 155°20 W

(6) Preliminary results

Time course of photosynthetic active radiation (PAR) and temperature, chlorophyll-*a* concentrations and DMS were shown in Figs. 4.19.1, 4.19.2 and 4.19.3, respectively.

(7) Data archives

All data obtained during MR15-03 cruise will be submitted to Data Management Group (DMG) of JAMSTEC after the sample analysis and validation.

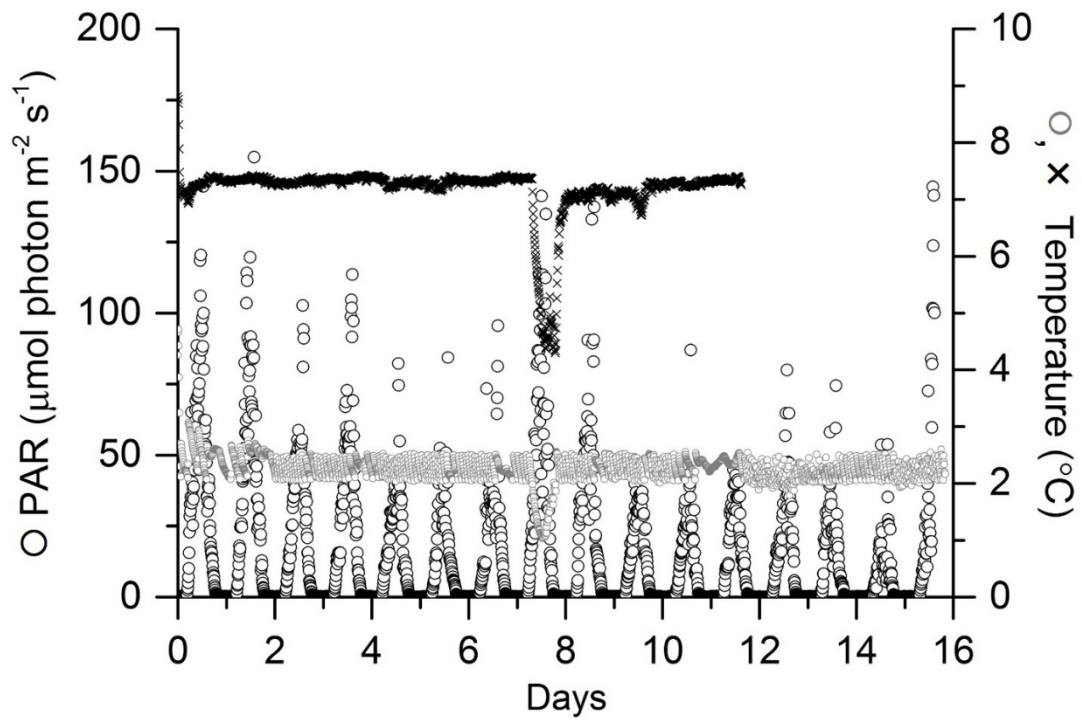

Fig. 4.19.1. Temporal change in photosynthetic active radiation (PAR, black open circle) and temperature (gray open circle and black cross represent for low- and high-temperature tank, respectively) during the incubation.

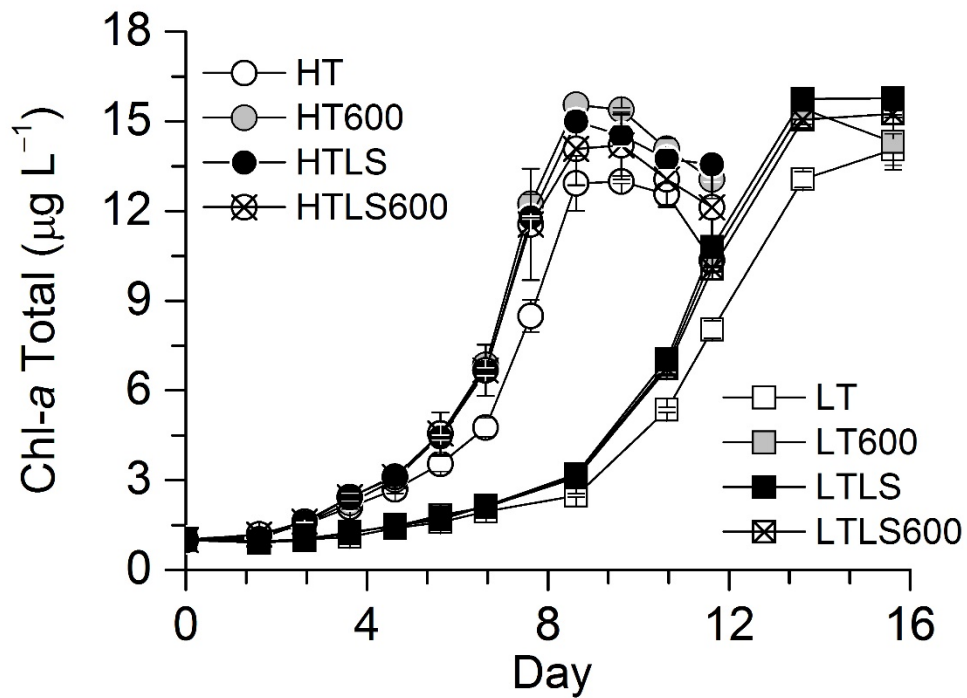

Fig. 4.19.2. Temporal change in chlorophyll-*a* concentration during the incubation.

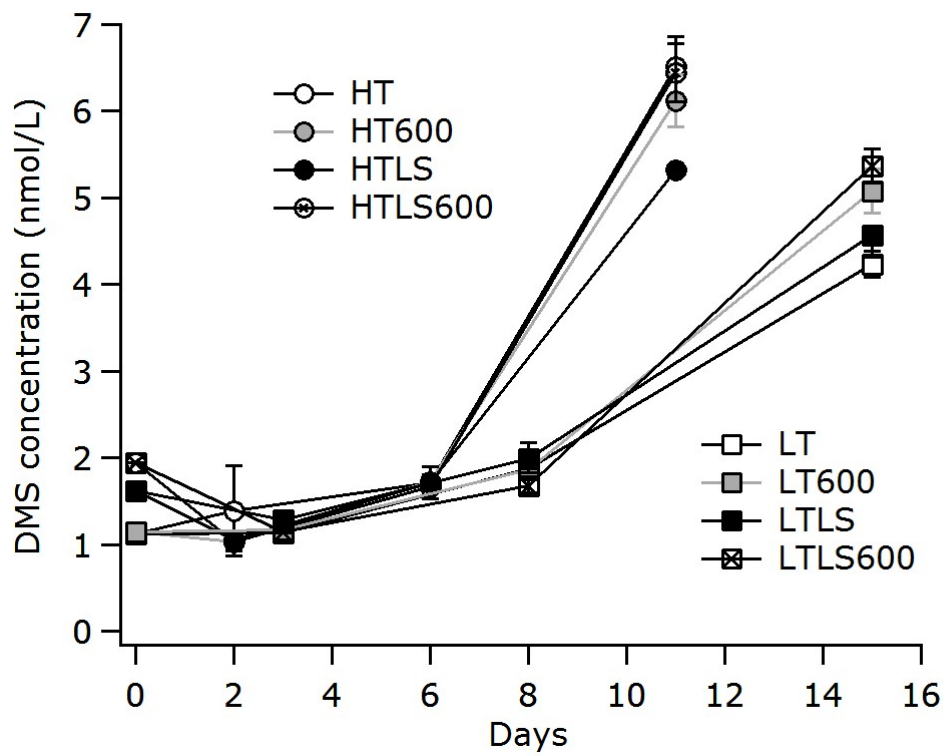

Fig. 4.19.3. Temporal change in DMS concentration during the incubation.

4.20. Plankton net, water sampling for microscopic observation, and biofouling of mooring equipment

(1) Personnel

Jonaotaro Onodera (JAMSTEC)

Koji Sugie (JAMSTEC)

Fumihiro Itoh (JAMSTEC)

Katsunori Kimoto (JAMSTEC), not onboard

Kohei Matsuno (Hokkaido Univ./Nat. Inst. Polar Res.), not onboard

Takahito Ikenoue (Mar. Ecol. Res. Inst.), not onboard

Minoru Kitamura (JAMSTEC), not onboard

(2) Objectives

The influence of recent hydrographic change including sea ice decrease in the Chukchi Sea and Canada Basin can be deciphered in plankton assemblages and marine ecosystems. The accumulation of observation data for plankton assemblage is required to understand a trend in marine ecosystem conditions in the western Arctic Ocean. In addition, it has been concerned that ocean acidification in the Arctic Ocean has directly influenced to calcareous shell-bearing planktons such as pteropod and foraminifer. The main objectives on plankton sampling in this cruise are to (1) check the relationship between distributions of water mass and plankton assemblages, and (2) to evaluate an influence of ocean acidification to calcareous plankton shells. In addition, some zooplankton subsamples are also supplied to the perfluorooctane sulfonic acid (PFOS) analysis (see subchapter 4.9).

(3) Parameters

Plankton assemblage and cell density in water estimated by microscopic observation

Density analysis of selected calcareous-plankton shells by μ X-CT scan

Life stage investigation of copepod fauna

(4) Instruments and methods

Water sampling

Water samples were taken by bucket and CTD niskin sampler. For the water sampling works, these samples were labelled as “microscopy” for Sugie and Onodera. Water of 1L was usually taken from sea surface and subsurface chlorophyll maximum layer. At some stations of eddy observation, the request of water sample at 50 m depth under patchy warm water-mass was included. Deeper sampling at 75 and 100 m depth were also planned to obtain at two sediment trap stations. Water samples for Dr. Sugie were fixed by adding pH-neutralized formalin (final formalin concentration: about 10%), and were stored in refrigerator (4°C). Based on Sugie’s water sample, large-size phytoplankton will be observed and counted by Utemol method after the cruise. Water

samples for Dr. Onodera were filtered on membrane filter (pore size 0.45 μm , 47mm diameter) during the cruise, and the filter was desalted by milli-Q water. The sample filters were placed in disposal petri dishes, and were air-dried in room temperature. The sample filters will be mainly applied (1) to observe suspended particles and (2) to count shell-bearing nano- and micro-phytoplankton under scanning electron microscope. Filter samples cannot be applied to observation of nano- and micro-plankton cells without hard parts such as coccolith and diatom valves. In order to estimate cell density, mean cell diameter, and mean cell volume of total nano and micro planktons (cell diameter 4-25 μm), the handheld automated cell counter Scepter2.0 of Merck Millipore were applied at 6 stations along 168°W line. The 5mL sample water was diluted to 50% with 5mL of milli-Q water, and then the disposable tips (pore size 40 μm and 60 μm) attached to Scepter2.0 were dipped into the diluted samples for 10-20 seconds.

Plankton net in the Chukchi Sea and Canada Basin

Twin-NORPAC net of Hokkaido Univ. was usually applied to obtain zooplankton samples in this cruise. The sampling by twin-NORPAC net was conducted for two layers: full depth (0 to bottom-7 m in shelf area, and 0-150 m in basin), and upper water-column layer (0 to thermocline in shelf, and 0-50 m in basin). Closing NORPAC net of JAMSTEC was also used to study vertical distribution of zooplanktons. The target sampling depths for closing NORPAC net is 50-100, 100-250, 250-300, and 300-500 m. The multi-layer sampling for upper 500 m water column will be completed by the combination of twin-NORPAC and closing net. Mesh sizes of twin-NORPAC are 335 μm (GG54) and 62 μm . The mesh size of closing net is 63 μm . The sampling by NORPAC net was conducted using a winch system for clean-niskin water sampling and a pulley temporarily attached on DYNACON arm. The 20kg weight supplied from Dr. Kitamura was used for plankton net. Samples were divided in the wet lab. These samples are to be shared by four research groups (Matsuno, Kimoto, Ikenoue for plankton research, and Yamashita for PFOS analysis in meso-zooplankton). The samples are divided during the cruise, and are shared as shown in Table 4.20-1.

Meso-zooplankton samples for Dr. Matsuno were fixed by filtered seawater with pH-neutralized formalin. In order to avoid deformation of soft plankton materials during shipment of samples after cruise, the sample bottle was filled with formalin sea water. The final formalin concentration in the sample is about 5-7%. Subsamples for calcareous zooplankton studied by Dr. Kimoto were washed in a 63 μm stainless steel mesh with fresh water, and then the sample on mesh was fixed by 100%EtOH. Some Kimoto's subsamples were simply fixed using pH-neutralized formalin (5-7%), in order to evaluate an influence of thermal deformation in molluscos part of specimen to 3D imaging during μX -CT scanning process. Subsamples for siliceous micro-zooplankton studied by Dr. Ikenoue were fixed on plastic mesh (42 μm mesh size) using 70%EtOH, and then remained particles on the mesh were stored in 400mL plastic bottle with 100%EtOH.

Table 4.20-1: Subsample share rule for NORPAC plankton net samples. The fraction represents aliquot size of subsamples. The symbol “---” represents that no subsample is supplied.

	Full Depth 335µm	Full Depth 62µm	Upper Layer 335µm	Upper Layer 62µm	Closing net 63µm
Matsuno	1/2	1/2	1/1	1/2	1/4
Yamashita	1/2	---	---	---	---
Kimoto	---	1/4	---	1/4	1/2
Ikenoue	---	1/4	---	1/4	1/4

Plankton sampling from ship’s pump water in the Bering Sea

Based on the request by Dr. Ikenoue, A4-sized mesh bag was made during the cruise using the roll of plastic mesh cloth (42µm mesh size) supplied from Dr. Ikenoue and instant glue for resin subjects. The frame of mesh bag was prepared using 2L PET bottle. This bottle frame has one hole at lower side, and the pump water filtered by mesh bag can go through the bottle frame. This bottle frame with mesh bag was set under the tap of natural sea water in storage room of sediment samples. The pump water is taken at ~4.5 m below sea surface. This sampling was conducted during transit in the Bering Sea. Samples were fixed over the plastic mesh (42µm mesh size) using 70%EtOH, and then remained particles over the mesh were stored in plastic sample bottle with 100%EtOH.

Biofouling to bottom-tethered mooring equipment

Some biofouling samples were taken from the recovered mooring equipment of Station BCH (71°20’N 157°36’W, 102 m water depth; Fig. 4.21-1 in the section of sediment trap). This mooring was deployed in last summer. The specimens attached to equipment were carefully put in disposal centrifuge tube, and the sample were fixed with 70%EtOH.

(5) Sampling summary lists

Table 4.20-2: Sample list of water samples for phytoplankton microscopic observation. The symbol “---” represents no sample was taken.

Station - CTD cast	Latitude (N)	Longitude (W)	Sample Depth (m)	Date & Time (UTC) YYYY/MM/DD hh:mm	Sample Water Vol. (L)	Filtered Water Vol. (L)
001	65°45.696’	168°45.198’	0	2015/09/06 06:37	1	0.40
001-01	65°45.696’	168°45.198’	29	2015/09/06 06:37	1	0.40
004	67°00.090’	168°45.000’	0	2015/09/06 16:28	1	0.50
004-01	67°00.090’	168°45.000’	12	2015/09/06 16:28	1	0.50
006	68°00.006’	168°45.120’	0	2015/09/07 00:18	1	0.93
006-02	68°00.006’	168°45.120’	23	2015/09/07 00:18	1	1.00
008	69°00.042’	168°44.868’	0	2015/09/07 09:20	1	1.00
008-01	69°00.042’	168°44.868’	22	2015/09/07 09:20	1	1.00

010	69°59.976'	168°44.982'	0	2015/09/07 16:53	1	1.00
010-01	69°59.976'	168°44.982'	20	2015/09/07 16:53	1	1.00
012	70°59.952'	168°45.126'	0	2015/09/08 00:52	1	0.50
012-01	70°59.952'	168°45.126'	15	2015/09/08 00:52	1	0.50
014	71°34.728'	157°50.256'	0	2015/09/09 01:46	1	0.50
014-01	71°34.728'	157°50.256'	51	2015/09/09 01:46	1	0.50
015-01	71°24.816'	157°30.042'	14	2015/09/09 04:18	1	0.75
015-01	71°24.816'	157°30.042'	118	2015/09/09 04:18	1	0.50
016	71°14.898'	157°09.666'	0	2015/09/09 07:08	1	0.50
016-01	71°14.898'	157°09.666'	35	2015/09/09 07:08	1	0.50
022	71°35.994'	154°50.220'	0	2015/09/11 15:10	1	1.00
022-01	71°35.994'	154°50.220'	29	2015/09/11 15:10	1	1.00
024	71°52.674'	156°01.782'	0	2015/09/11 22:17	1	1.00
024-01	71°52.674'	156°01.782'	35	2015/09/11 22:17	1	1.00
032	72°00.000'	154°42.402'	0	2015/09/13 22:13	1	0.50
032-01	72°00.000'	154°42.402'	28	2015/09/13 22:13	1	1.00
034-01	71°44.000'	155°20.000'	10	2015/09/14 05:20	1	---
037	72°11.040'	155°39.072'	0	2015/09/14 12:34	1	1.00
037-01	72°11.040'	155°39.072'	21	2015/09/14 12:34	1	1.00
037-01	72°11.040'	155°39.072'	50	2015/09/14 12:34	1	1.00
039	72°23.538'	155°28.002'	0	2015/09/15 00:16	1	1.00
039-01	72°23.538'	155°28.002'	50	2015/09/15 00:16	1	1.00
039-01	72°23.538'	155°28.002'	67	2015/09/15 00:16	1	1.00
047	71°57.096'	158°00.072'	0	2015/09/15 19:05	---	1.00
047-01	71°57.096'	158°00.072'	17	2015/09/15 19:05	---	1.00
053	72°20.424'	155°23.496'	0	2015/09/16 19:54	---	1.00
053-04	72°20.424'	155°23.496'	19	2015/09/16 19:54	---	1.00
053-04	72°20.424'	155°23.496'	50	2015/09/16 19:54	---	1.00
054	72°28.368'	155°24.084'	0	2015/09/18 19:20	1	1.00
054-02	72°28.260'	155°23.472'	19	2015/09/18 21:15	1	1.00
054-02	72°28.260'	155°23.472'	20	2015/09/18 21:15	1	1.00
054-02	72°28.260'	155°23.472'	50	2015/09/18 21:15	1	1.00
054-02	72°28.260'	155°23.472'	75	2015/09/18 21:15	1	1.00
054-02	72°28.260'	155°23.472'	100	2015/09/18 21:15	1	1.00
056	72°16.770'	155°58.536'	0	2015/09/21 07:55	1	2.00
056-12	72°16.770'	155°58.536'	19	2015/09/21 07:55	1	2.00
062	71°49.938'	153°49.476'	0	2015/09/22 16:50	---	1.00
062-01	71°49.938'	153°49.476'	26	2015/09/22 16:50	---	1.00
063	72°22.254'	155°31.128'	0	2015/09/23 06:25	---	1.00
063-01	72°22.254'	155°31.128'	40	2015/09/23 06:25	---	1.00
063-01	72°22.254'	155°31.128'	50	2015/09/23 06:25	---	1.00
064	72°15.882'	155°57.948'	0	2015/09/23 09:52	---	1.00
064-01	72°15.882'	155°57.948'	36	2015/09/23 09:52	---	1.00
064-01	72°15.882'	155°57.948'	50	2015/09/23 09:52	---	1.00
065	72°11.670'	156°15.498'	0	2015/09/23 13:07	---	1.00
065-01	72°11.670'	156°15.498'	18	2015/09/23 13:07	---	1.00
065-01	72°11.670'	156°15.498'	50	2015/09/23 13:07	---	1.00
066	72°15.990'	156°24.882'	0	2015/09/23 16:00	---	1.00
066-01	72°15.990'	156°24.882'	35	2015/09/23 16:00	---	1.00
066-01	72°15.990'	156°24.882'	50	2015/09/23 16:00	---	1.00
067	72°10.056'	155°30.918'	0	2015/09/23 21:13	---	1.00
067-01	72°10.056'	155°30.918'	13	2015/09/23 21:13	---	1.00
067-01	72°10.056'	155°30.918'	50	2015/09/23 21:13	---	1.00
068	72°10.476'	156°13.452'	0	2015/09/24 00:24	---	1.00
068-01	72°10.476'	156°13.452'	39	2015/09/24 00:24	---	1.00
068-01	72°10.476'	156°13.452'	50	2015/09/24 00:24	---	1.00
069	72°10.074'	155°58.482'	0	2015/09/24 02:45	---	1.00
069-01	72°10.074'	155°58.482'	24	2015/09/24 02:45	---	1.00
069-01	72°10.074'	155°58.482'	50	2015/09/24 02:45	---	1.00

070	72°10.056'	156°40.722'	0	2015/09/24 06:00	---	1.00
070-01	72°10.056'	156°40.722'	31	2015/09/24 06:00	---	0.95
070-01	72°10.056'	156°40.722'	50	2015/09/24 06:00	---	1.00
075	73°12.534'	157°48.222'	0	2015/09/24 23:10	1	1.00
075-01	73°12.534'	157°48.222'	44	2015/09/24 23:10	1	1.00
082	73°08.154'	162°17.916'	0	2015/09/25 21:25	---	1.00
082-01	73°08.154'	162°17.916'	15	2015/09/25 21:25	---	1.00
084	73°03.480'	164°36.120'	0	2015/09/26 04:29	---	1.00
084-01	73°03.480'	164°36.120'	19	2015/09/26 04:29	---	1.00
085	73°18.306'	160°46.746'	0	2015/09/26 17:25	1	1.00
085-02	73°18.618'	160°45.606'	13	2015/09/26 19:00	1	1.00
085-02	73°18.618'	160°45.606'	20	2015/09/26 19:00	1	1.00
085-02	73°18.618'	160°45.606'	30	2015/09/26 19:00	1	1.00
085-02	73°18.618'	160°45.606'	50	2015/09/26 19:00	1	1.00
085-02	73°18.618'	160°45.606'	75	2015/09/26 19:00	1	1.00
085-02	73°18.618'	160°45.606'	100	2015/09/26 19:00	1	1.00
094	73°28.530'	160°08.172'	0	2015/09/27 22:05	1	1.00
094-01	73°28.530'	160°08.172'	32	2015/09/27 22:05	1	1.00
098	74°27.702'	166°38.136'	0	2015/09/28 18:06	---	1.00
098-01	74°27.702'	166°38.136'	26	2015/09/28 18:06	---	1.00
100	74°00.006'	168°45.288'	0	2015/09/29 04:42	1	1.00
100-01	74°00.006'	168°45.288'	16	2015/09/29 04:42	1	1.00
102	72°00.108'	168°44.748'	0	2015/09/29 22:27	1	1.00
102-01	72°00.108'	168°44.748'	23	2015/09/29 22:27	1	1.00
106	67°59.904'	168°44.820'	0	2015/10/01 00:07	---	1.00
106-01	67°59.904'	168°44.820'	15	2015/10/01 00:07	---	1.00
108	67°00.030'	168°44.892'	0	2015/10/03 09:19	---	1.00
108-01	67°00.030'	168°44.892'	35	2015/10/03 09:19	---	1.00
109	66°00.120'	168°45.042'	0	2015/10/03 16:01	---	1.00
109-01	66°00.120'	168°45.042'	0	2015/10/03 16:01	---	0.50

Table 4.20-3: Summary for NORPAC net sampling. The time zone in this list is UTC-11. Alphabets in the column “Notes” represent who shares the sample among Drs. Matsuno (M), Yamashita (Y), Kimoto (K, and K_f for formalin fixation sample), and Ikenoue (I). The fraction remarked in column “Notes” represents unusual aliquot size of subsamples due to a mistake in sample division.

Stn.	Latitude (N)	Longitude (W)	Date & Time MMDD hh:mm	Wire Length (m), Angle (°), and Depth (m)			Mesh Size (μm)	Flow-meter		Notes
								No.	Reading	
001	65°45.01'	168°45.95'	09/05 20:48	0~ 46 m length	7°	0~ 46 m depth	335	1562	358	MY
							62	1858	535	MKI
	65°45.01'	168°45.95'	09/05 21:02	0~ 24	8	0~ 24	335	1562	180	M
							62	1858	226	MKI
004	67°00.04'	168°44.99'	09/06 06:24	0~ 38	5	0~ 38	335	1562	262	MY
							62	1858	352	MKI
	67°00.06'	168°45.17'	09/15 06:33	0~ 20	7	0~ 20	335	1562	240	M
							62	1858	262	MKI
006	67°59.85'	168°47.89'	09/07 15:23	0~ 53	3	0~ 53	335	1562	359	MY
							62	1858	380	MKI
	67°59.87'	168°48.07'	09/07 15:37	0~ 19	1	0~ 19	335	1562	164	M
							62	1858	136	MKI
008	68°59.92'	168°45.55'	09/07 23:12	0~ 40	5	0~ 40	335	1562	293	MY
							62	1858	260	MKI
	68°59.92'	168°45.55'	09/07 23:25	0~ 10	5	0~ 10	335	1562	91	M
							62	1858	125	MKI

010	69°59.79'	168°45.08'	09/07 06:36	0~ 34	10	0~ 33	335	1562	290	MY
							62	1858	215	MKI
	69°59.79'	168°45.08'	09/07 06:44	0~ 25	2	0~ 25	335	1562	285	M
							62	1858	195	MKI
012	70°59.75'	168°45.14'	09/07 14:39	0~ 38	13	0~ 37	335	1562	353	MY
							62	1858	410	MKI
	70°59.75'	168°45.14'	09/07 14:47	0~ 19	7	0~ 19	335	1562	142	M
							62	1858	145	MKI
014	71°34.69'	157°49.67'	09/09 15:40	0~ 59	10	0~ 58	335	1562	455	MY
							62	1858	308	MKI
	71°34.68'	157°49.60'	09/09 15:53	0~ 40	2	0~ 40	335	1562	282	M
							62	1858	286	MKI
015	71°25.01'	157°30.73'	09/09 18:24	0~117	0	0~117	335	1562	717	MY
							62	1858	368	MKI
	71°25.09'	157°30.93'	09/09 18:38	0~ 80	1	0~ 80	335	1562	558	M
							62	1858	305	MKI
016	71°15.04'	157°09.78'	09/09 20:49	0~ 41	3	0~ 41	335	1562	266	MY
							62	1858	207	MKI
	71°15.09'	157°09.68'	09/09 20:59	0~ 30	5	0~ 30	335	1562	207	M
							62	1858	162	MKI
022	71°36.64'	154°51.69'	09/11 04:56	0~ 37	15	0~ 36	335	1562	400	MY
							62	1858	505	MKI
	71°36.64'	154°51.69'	09/11 05:05	0~25	11	0~25	335	1562	215	M
							62	1858	227	MKI
023	71°45.75'	155°18.05'	09/11 08:21	0~150 +20	28	0~150	335	1562	2228	MY
							62	1858	2375	MKI
	71°46.02'	155°18.73'	09/11 08:40	0~ 50	10	0~ 49	335	1562	650	M
							62	1858	752	MKI
024	71°53.33'	156°03.37'	09/11 12:16	0~ 79 +5	19	0~ 79	335	1562	950	MY
							62	1858	1082	MKI
	71°53.46'	156°03.69'	09/11 12:29	0~ 37	17	0~ 35	335	1562	428	M
							62	1858	434	MKI
032	72°00.15'	154°44.82'	09/13 13:22	0~150 +1	7	0~150	335	1562	920	MY
							62	1858	750	M1/4 K _f I 1/2
	72°00.18'	154°45.22'	09/13 13:38	0~ 50	0	0~ 50	335	1562	387	M
							62	1858	287	MK _f I
037	72°11.94'	155°42.72'	09/14 03:13	0~150	5	0~149	335	1562	1010	MY
							62	1858	730	MKI
	72°12.08'	155°43.40'	09/14 03:29	0~ 50 +2	15	0~ 50	335	1562	495	M
							62	1858	335	KI 1/2
039	72°23.50'	155°28.33'	09/14 14:33	0~150	2	0~150	335	1562	1070	MY
							62	1858	1095	MKI
	72°23.42'	155°28.69'	09/14 14:49	0~ 50 +2	13	0~ 51	335	1562	348	M
							62	1858	328	MKI
054	72°29.21'	155°24.60'	09/18 17:35	0~150 +1	7	0~150	335	1562	835	MY
							62	1858	592	MKI
	72°29.27'	155°25.10'	09/18 17:53	0~ 50	7	0~ 50	335	1562	392	M
							62	1858	207	MKI
054 Closing net	72°29.31'	155°25.59'	09/18 18:08	50 ~100	3	60 ~100	63	2888	15	MKI
	72°29.37'	155°25.98'	09/18 18:20	100 ~250 +2	7	119 ~250	63	2888	97	MKI
	72°29.44'	155°26.42'	09/18 18:39	250 ~300 +1	5	259 ~300	63	2888	10	MKI
	72°29.54'	155°26.81'	09/18 18:58	300 ~500 +1	4	300 ~500	63	2888	12	3sec stop @300m, MKI
062	71°49.83'	153°47.39'	09/22 08:27	0~150 +5	14	0~150	335	1562	1010	MY
							62	1858	640	MK _f I
	71°49.83'	153°46.64'	09/22 08:43	0~ 50	1	0~ 50	335	1562	125	M
							62	1858	210	M1/4 K _f I 1/2

075	73°12.31'	157°47.33'	09/24 13:49	0~150 +4	13	0~150	335	1562	1160	MY
	73°12.32'	157°47.00'	09/24 14:07	0~ 50	4	0~ 50	62	1858	1478	MKI
078	72°47.98'	161°23.68'	09/25 00:12	0~ 39	2	0~ 39	335	1562	548	M
	72°48.02'	161°23.61'	09/25 00:22	0~ 24	5	0~ 24	62	1858	575	MKI
084	73°03.37'	164°38.12'	09/25 18:24	0~ 65	3	0~ 65	335	1562	405	MY
	73°03.40'	164°38.52'	09/25 18:36	0~ 18	2	0~ 18	62	1858	420	MKI
085	73°18.80'	160°45.48'	09/26 08:54	0~150	4	0~150	335	1562	138	M
	73°19.01'	160°45.38'	09/26 09:10	0~ 50 +1	10	0~ 50	62	1858	242	MKI
085 Closing net	73°19.11'	160°45.39'	09/26 09:24	50 ~100 +5	18	51 ~100	63	2888	322	MKI
	73°19.23'	160°45.26'	09/26 09:36	100 ~250	3	101 ~250	63	2888	369	MKI
	73°19.41'	160°45.41'	09/26 09:54	250 ~300 +2	6	246 ~300	63	2888	1072	MKI
	73°19.59'	160°45.62'	09/26 10:18	300 ~500	3	303 ~500	63	2888	830	MKI
092	73°29.25'	162°14.43'	09/27 05:50	0~150 +2	10	0 ~150	335	1562	470	M
	73°29.26'	162°14.20'	09/27 06:07	0~ 50	5	0~ 50	62	1858	1205	MKI
094	73°28.49'	160°06.73'	09/27 13:15	0~150 +6	18	0~148	335	1562	282	M
	73°28.52'	160°06.46'	09/27 13:30	0~ 50	5	0~ 50	62	1858	1285	MKI
094 Closing net	73°28.53'	160°06.30'	09/27 13:40	50 ~100	10	49 ~98	335	1562	400	M
	73°28.53'	160°06.09'	09/27 13:52	100 ~250 +8	14	100 ~250	62	1858	470	MKI
	73°28.55'	160°05.84'	09/27 14:11	250 ~300 +12	17	254 ~298	63	2888	400	MKI
	73°28.60'	160°05.56'	09/27 14:29	300 ~500	0	300 ~500	63	2888	240	MKI
100	74°00.04'	168°44.99'	09/28 18:56	0~150	3	0~150	335	1562	408	MY
	74°00.08'	168°45.24'	09/28 19:13	0~ 10	4	0~ 10	62	1858	840	MKI
102	71°59.84'	168°44.46'	09/29 12:20	0~ 43	6	0~ 43	335	1562	142	M
	71°59.80'	168°44.44'	09/29 12:31	0~ 30	7	0~ 30	62	1858	136	MKI
							335	1562	332	MY
							62	1858	300	MKI
							335	1562	292	M
							62	1858	269	MKI

Table 4.20-4: Reading value of flow-meters in six casts for flowmeter calibration test at Station 109. The wire length is 45 m. Wire angle for each cast is shown in parenthesis.

S/N	1st (3°)	2nd (1°)	3rd (6°)	4th (0°)	5th (2°)	6th (0°)
1562	380	362	398	360	380	395
1858	438	422	432	422	431	427
2888	311	499	395	403	404	383

Table 4.20-5: Sample summary for ship's pump net.

Sample ID	Sampled period Start End (UTC) YYYY/MM/DD hh:mm	Sampled Position Start End	Remarks
Pump net #01	2015/09/02 04:24 2015/09/02 06:55	52°55.8025'N 171°14.4402'E 53°16.0496'N 171°51.7660'E	
Pump net #02	2015/09/02 07:00 2015/09/02 08:53	53°16.7158'N 171°53.0432'E 53°33.1321'N 172°20.2200'E	
Pump net #03	2015/09/02 09:00 2015/09/02 20:55	53°34.1822'N 172°21.8349'E 55°18.5335'N 175°03.0760'E	Qualitative
Pump net #04	2015/09/02 21:00 2015/09/03 04:20	55°19.0242'N 175°03.8462'E 56°15.3064'N 176°33.8249'E	
Pump net #05	2015/09/03 04:30 2015/09/03 07:50	56°16.7737'N 176°36.2456'E 56°46.2124'N 177°24.4912'E	
Pump net #06	2015/09/03 08:01 2015/09/03 20:40	56°47.8709'N 177°27.1826'E 58°38.6416'N 179°26.0427'W	
Pump net #07	2015/09/03 21:00 2015/09/04 02:30	58°41.4718'N 179°20.8971'W 59°29.6167'N 178°08.9242'W	Qualitative
Pump net #08	2015/09/04 02:50 2015/09/04 08:15	59°32.6252'N 178°04.2132'W 60°29.7061'N 176°48.6083'W	
Pump net #09	2015/09/04 08:25 2015/09/04 20:33	60°31.8581'N 176°46.2798'W 62°51.9082'N 173°29.0753'W	
Pump net #10	2015/09/04 20:45 2015/09/05 01:06	62°53.8535'N 173°24.3587'W 63°45.6977'N 172°24.8814'W	
Pump net #11	2015/09/05 01:15 2015/09/05 03:30	63°47.4518'N 172°21.8078'W 64°06.1480'N 171°19.2901'W	
Pump net #12	2015/09/05 22:45 2015/09/06 00:25	64°34.5084'N 168°14.8908'W 64°49.2319'N 168°31.1856'W	Qualitative
Pump net #13	2015/09/06 00:33 2015/09/06 03:51	64°50.6212'N 168°32.6490'W 65°27.2822'N 168°31.8390'W	Qualitative
Pump net #14	2015/09/06 04:01 2015/09/06 04:55	65°29.1814'N 168°31.3386'W 65°39.1906'N 168°30.2607'W	
Pump net #15	2015/10/03 19:35 2015/10/03 21:10	65°40.4650'N 168°29.5800'W 65°23.5793'N 168°32.5500'W	
Pump net #16	2015/10/03 21:27 2015/10/03 23:00	65°20.4920'N 168°33.5230'W 65°03.3680'N 168°39.0259'W	
Pump net #17	2015/10/03 23:23 2015/10/04 01:24	64°59.0490'N 168°40.3060'W 64°37.1036'N 168°26.9737'W	
Pump net #18	2015/10/04 01:52 2015/10/04 05:40	64°31.6650'N 168°23.6710'W 63°50.3839'N 167°56.9403'W	
Pump net #19	2015/10/04 05:50 2015/10/04 19:50	63°48.4940'N 167°55.7390'W 61°18.6594'N 167°33.8747'W	Qualitative
Pump net #20	2015/10/04 20:06 2015/10/04 21:32	61°15.5870'N 167°34.9760'W 61°01.1162'N 167°40.4330'W	
Pump net #21	2015/10/04 21:47 2015/10/05 01:00	60°58.6080'N 167°41.3550'W 60°28.9670'N 167°50.9841'W	
Pump net #22	2015/10/05 01:14 2015/10/05 05:41	60°26.4760'N 167°52.4110'W 59°34.7284'N 167°52.5920'W	
Pump net #23	2015/10/05 06:26 2015/10/05 17:00	59°26.4200'N 167°48.7820'W 57°42.7560'N 167°22.2375'W	
Pump net #24	2015/10/05 17:31 2015/10/05 21:57	57°39.2080'N 167°21.1120'W 56°54.9675'N 167°10.0498'W	

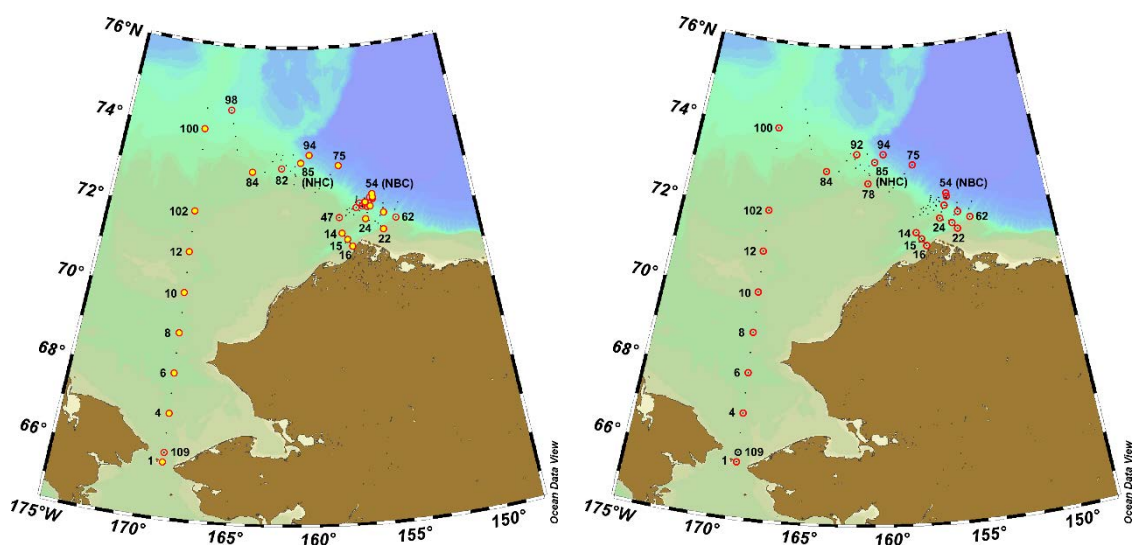

Fig. 4.20-1: Locality maps of water (left side) and plankton net samples (right side). In the left map, symbols of yellow point and red circle represents the locality of water and filter samples, respectively. Tiny dots show all station position in the MR15-03 leg 1. The symbols of red circle, blue dot, and black circle in the right map represent the location of twin-NORPAC, closing net samples, and flow-meter calibration casts, respectively.

(6) Preliminary results

Water samples for phytoplankton observation were taken from 39 and 23 stations for water and filter samples, respectively (Table 4.20-2, Fig. 4.20-1). Twin-NORPAC net and closing net was conducted at 25 stations (Table 4.20-3 and Fig. 4-20-1). In order to estimate filtered water volume of plankton net, six casts for flow-meter calibration was conducted at Station 109 (Table 4.20-4). During the plankton sampling of ship's pump water, water flow volume of ship's pump was ~10 L/min. Total of 24 pump net samples were obtained although some samples are to be treated as qualitative sample due to spilling out of sample waters from the top of mesh bag. This trouble was due to clogging mesh by abundant suspended particles and mucous produced by phytoplankton (Table 4.20-5). The biofouling samples at Station BCH were taken from ADCP WHS-300 deployed at 91 m, and resin float deployed at 96 m depth (Fig. 4.20-2).

All assemblage analyses of plankton net and water samples based on microscopic observation are conducted after cruise. Here we briefly tabulate the result of cell counter Scepter 2 along 168°W observation line (Table 4.20-6).

Table 4.20-6: The result summary of cell counter Scepter 2.0 at Stations 1, 4, 6, 8, and 12 in 168°W observation line.

Station	Sample Depth (m)	Sensor Type and Range (µm)	Mean Cell Diameter (µm)	Mean Cell Volume (pL)	Mean Cell Count (no./mL)
1	0	60 (6-36)	11.54	0.81	5.20E+02
		40 (3-18)	4.98	0.06	2.88E+03
	29	60 (6-36)	9.21	0.41	6.40E+02
		40 (3-18)	5.18	0.07	4.44E+03
4	0	60 (6-36)	10.69	0.64	8.40E+02
		40 (3-18)	4.92	0.06	1.07E+04
	12	60 (6-36)	7.52	0.22	8.00E+02
		40 (3-18)	3.66	0.03	3.59E+04
6	0	60 (6-36)	12.34	0.98	8.40E+02
		40 (3-18)	5.68	0.10	4.00E+03
	23	60 (6-36)	8.26	0.30	4.40E+02
		40 (3-18)	5.60	0.09	4.24E+03
8	0	60 (6-36)	8.80	0.36	5.60E+02
		40 (3-18)	4.55	0.05	6.61E+03
	22	60 (6-36)	17.46	2.79	1.60E+02
		40 (3-18)	4.46	0.05	2.80E+03
12	0	60 (6-36)	8.04	0.27	9.20E+02
		40 (3-18)	3.19	0.02	3.37E+05
	15.	60 (6-36)	8.37	0.31	6.40E+02
		40 (3-18)	4.10	0.04	3.48E+03

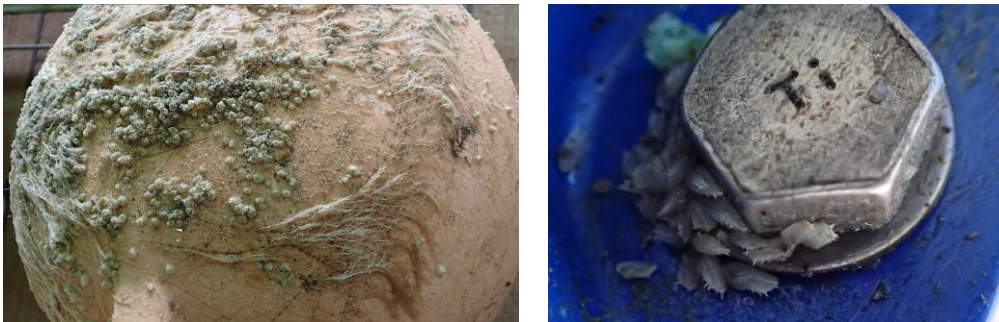

Fig. 4.20-2: The images of biofouling on the bottom-tethered physical oceanographic mooring at Station BCH deployed from September 2014 to September 2015. The left image shows biofouling on plastic float deployed at 96 m depth, and right image shows a small mass of tiny bivalves (?) attached around the bolt of ADCP deployed at 91 m depth.

(7) Data archives

These data obtained in this cruise will be submitted to the Data Management Group of JAMSTEC, and will be opened to the public via “Data Research System for Whole Cruise Information in JAMSTEC (DARWIN)” in JAMSTEC web site.

<<http://www.godac.jamstec.go.jp/darwin/e>>

4.21. Sediment trap

(1) Personnel

Jonaotaro Onodera (JAMSTEC), Naomi Harada (JAMSTEC)*, Yuichiro Tanaka (AIST)*, Motoyo Itoh (JAMSTEC)*, Shigeto Nishino (JAMSTEC), Katsunori Kimoto (JAMSTEC)*, Kazumasa Oguri (JAMSTEC)*, Yusuke Kawaguchi (JAMSTEC), Takashi Kikuchi (JAMSTEC)*, Eiji Watanabe (JAMSTEC)*, Kohei Mizobata (TUMSAT)*, Fumihiro Itoh (JAMSTEC), Koji Sugie (JAMSTEC), Keisuke Matsumoto (MWJ technical staff leader for mooring operation), Keisuke Takeda (MWJ), Tomohide Noguchi (MWJ), Rei Itoh (MWJ), Okumura Shinya (GODI technical staff for bathymetry survey), Wataru Tokunaga (GODI for bathymetry survey), Yutaro Murakami (GODI for bathymetry survey)

*: not onboard

(2) Objectives

In the Northwind Abyssal Plain (NAP), contribution of oceanic eddies to material transportation originated from the Barrow Canyon and the eastern Chukchi shelf have been suggested from the previous sediment trap experiment at Station NAP (75°N 162°W), and simulation study on physical oceanography and lower trophic marine ecosystem (Watanabe et al. 2014). To monitor the oceanographic condition regarding shelf-basin interaction in upper stream of sea-surface flow around Station NAP, bottom-tethered mooring with sediment trap and physical oceanographic sensors were planned at two stations around pass way of oceanic eddies (the area off Barrow Canyon, and Station NAP).

(3) Parameters

Downward flux and the composition of settling particles, current, water temperature, salinity, dissolved oxygen, pH, chlorophyll-*a*, underwater camera

(4) Instruments and methods

The deployed equipment are tabulated in the mooring operation log (Table 4.21-2). The response test of acoustic releasers in deep water was conducted in transit from the Hachinohe to the Bering Strait. The releasers for response test were attached to CTD frame, and the frame with releasers was sent to 1000 m depth. The communication test of releasers was conducted using a transducer attached to ship bottom.

Because the planned depth of top buoy is shallow (50-60m), water depth of deployed position must be nearly the same as planned depth or deeper. In order to select the mooring deployment position as far as flat and low slope angle, bathymetry survey was conducted before deployment. Sample cups of sediment trap were filled with filtered sea water obtained from 1000m depth in the southern Canada Basin. This sea water contains 5% formalin, and the pH was neutralized to 8.0~8.1 by sodium tetraborate.

The deploying method was a top buoy first and sinker last. After the deployment, acoustic ranging was conducted from ship to deployed releaser and transponder to determine the mooring location. Because the planned mooring depth of Nichiyu releasers at Station NBC was deeper than 2000m, ship's transducer cannot be applied. Portable deck unit and transducer for Nichiyu releasers was set on the after main deck. These moorings will be recovered in next September.

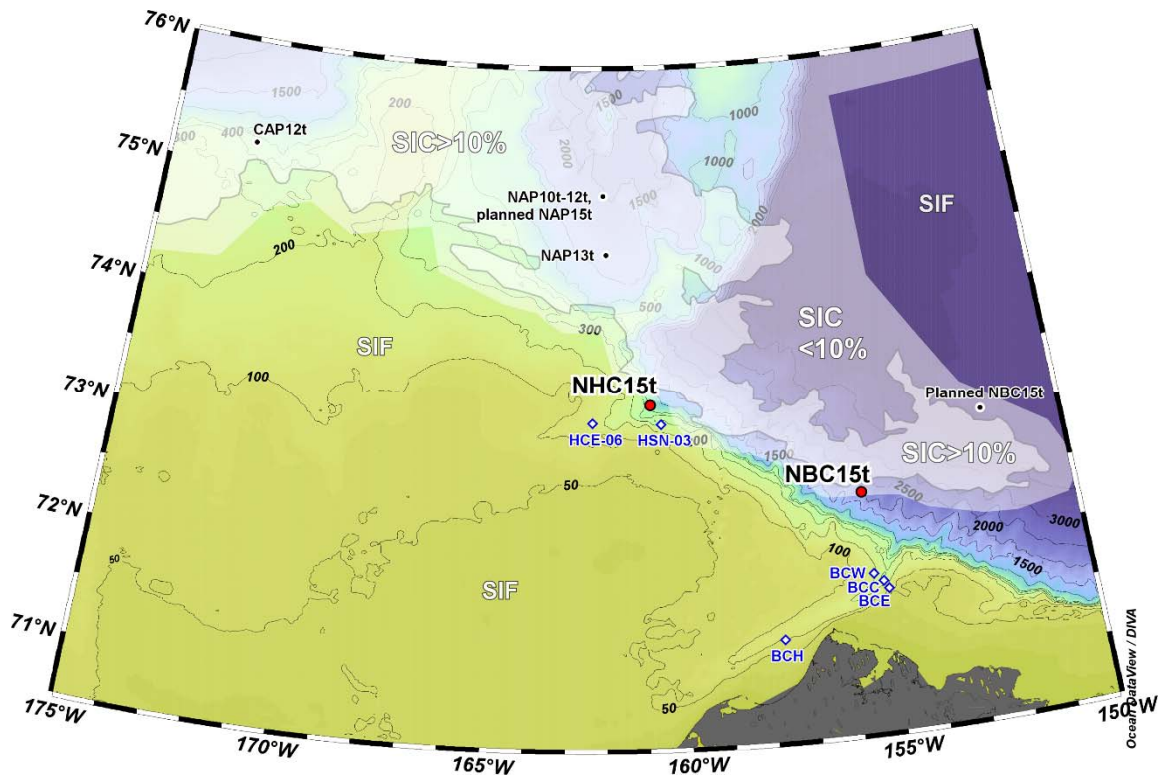

Fig. 4.21-1: The map with JAMSTEC sediment trap stations and sea ice distribution at 15 September 2015 (from NOAA ice chart). SIC and SIF are the abbreviation of sea ice concentration and sea ice free, respectively. The blue symbol represents physical oceanography moorings of JAMSTEC around Stations NBC15t & NHC15t.

(5) Mooring operation log and mooring position

Table 4.21-1: Mooring deployment log and mooring position at Station NBC15t

Start time of deploy (UTC)	9 Sep. 2015	00:15		
Start position of deploy (GPS)	72°27.8970'N	155°28.8529'W		
Depth of start position	1913.0 m			
Time in water of instruments and anchor				
Frame#	Type	Model	s/no.	time (UTC)
1	CT	SBE37-IDO	9417	00:17
	pH	SP-11	346258010	

	Chl.	MFL50W-USB	20	
-	Transponder	XT6001-13	60644	
2	CT	SBE37-SM	13677	00:24
	CT	SBE37-SM	13678	
3	pH	SP-11	346259009	00:28
	DO	ARO-USB	131	
4	ADCP	WHS-300	13838	00:30
	CT	A7CT	283	
5	CT	SBE37-SM	7668	00:36
6	Trap	SMD26S-6000	98063	00:49
	Camera	(Handmade)	13G1	
7	Trap	SMD26S-6000	98057	01:41
8	Releaser	Model-L	4441	02:30
	Releaser	Model-L	4447	
-	Anchor	1000kg in air	-	02:35
Position of anchor release		72°28.3173'N 155°22.9688'W		
Depth of anchor release position		2002.0 m		
Transponder position		72°28.3407'N 155°24.3878'W		
Releaser position		N/A (triangulation was not conducted)		
Water depth of mooring position		1999.8 m		
Estimated top depth		62 m		

Table 4.21-2: Mooring deployment log at Station NHC15t

Start time of deploy (UTC)		27 Sep. 2015	00:17	
Start position of deploy (GPS)		73°18.3853'N 160°47.2019'W		
Depth of start position		429.0 m		
Time in water of instruments and anchor				
Frame#	Type	Model	s/no.	time (UTC)
	CT	A7CT2-USB	274	
1	pH	SP-11	346258008	00:21
	Chl.	MFL50W-USB	19	
-	Transponder	XT6001-13	60645	00:21
	CT	SBE37-SM	13677	
2	DO	ARO-USB	130	00:24
	pH	SP-11	346259009	
3	ADCP	WHS-300	13838	00:32
4	Trap	SMD26S-6000	98063	00:50
	Camera	(Handmade)	13G2	
5	Releaser	Model-L	4391	01:06
	Releaser	Model-LGC	134	
-	Anchor	1000kg in air	-	01:15
Position of anchor release		73°18.0766'N 160°46.8579'W		
Depth of anchor release position		426.0 m		
Transponder position		73°18.1410'N 160°46.9216'W		
Releaser position		73°18.12'N 160°46.865'W		
Water depth of tranponder position		424.757 m		
Water depth of releaser position		425.5 m		
Estimated top depth		52 m		

(6) Preliminary results

The response test of applying releasers in water successfully completed using ship's acoustic communication system. Because of unfavorable ice condition during the cruise (Fig. 4.21-1), the R/V *Mirai* could not reach to the planned position of Station NBC15t (NBC: North of Barrow Canyon). As the alternate position of planned NBC15t, the new position of NBC15t was selected by bathymetry survey just before the mooring deployment operation (Fig. 4.21-2). After the changes of mooring rope length and combination of applying sensors (Fig. 4.21-3), the mooring NBC15t was deployed in lower shelf slope of the southwestern Canada Basin (Fig. 4.21-1). In the response and ranging test of deployed two releasers, one releaser (s/n 4441) showed a clear response to call from ship, and the signal from another releaser (s/n 4447) was relatively weak. The water depth of mooring position was nearly the same as target depth judging from the position and depth of transponder and the water depth variation around the anchor drop position (Fig.4.21-2, Table 4.21-1). Station NBC15t has located just north of eddy observation line in this cruise.

Because the Northwind Abyssal Plain (NAP) had been also covered by sea ice when we was in the northern Chukchi Sea (Fig. 4.21-1), the alternate site of NAP15t was to be out of NAP region. Using the mooring equipment prepared for NAP15t, sediment trap mooring was newly designed for the Northern Hanna Canyon (NHC) during the cruise (Fig. 4.21-1). The mooring was deployed as the mooring ID of NHC15t after bathymetry survey (Figs. 4.21-4 and 4.21-5). Based on the estimated positions of releasers and bathymetry survey, water depth of NHC15t position is 425.5 m. The estimated depth of mooring top is 52 m (Table 4.21-2).

(7) Data archives

These data obtained in this cruise will be submitted to the Data Management Group of JAMSTEC, and will be opened to the public via “Data Research System for Whole Cruise Information in JAMSTEC (DARWIN)” in JAMSTEC web site.

<<http://www.godac.jamstec.go.jp/darwin/e>>

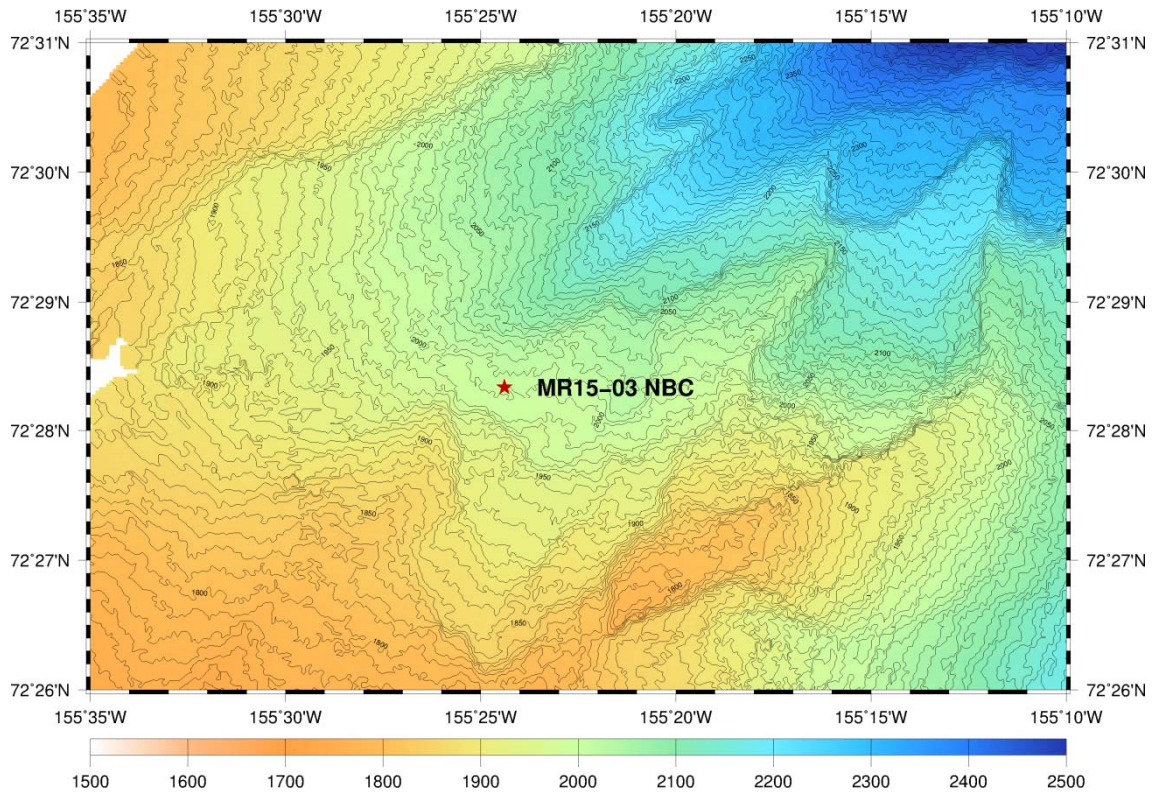

Fig. 4.21-2: The results on bathymetry survey around Station NBC15t. The red star symbol shows the location of Station NBC15t.

Deployment

Station NBC15t

72°28.3407'N 155°24.3878'W
2000 m water depth, transponder at 70 m

9 Sep. 2015
final ver.

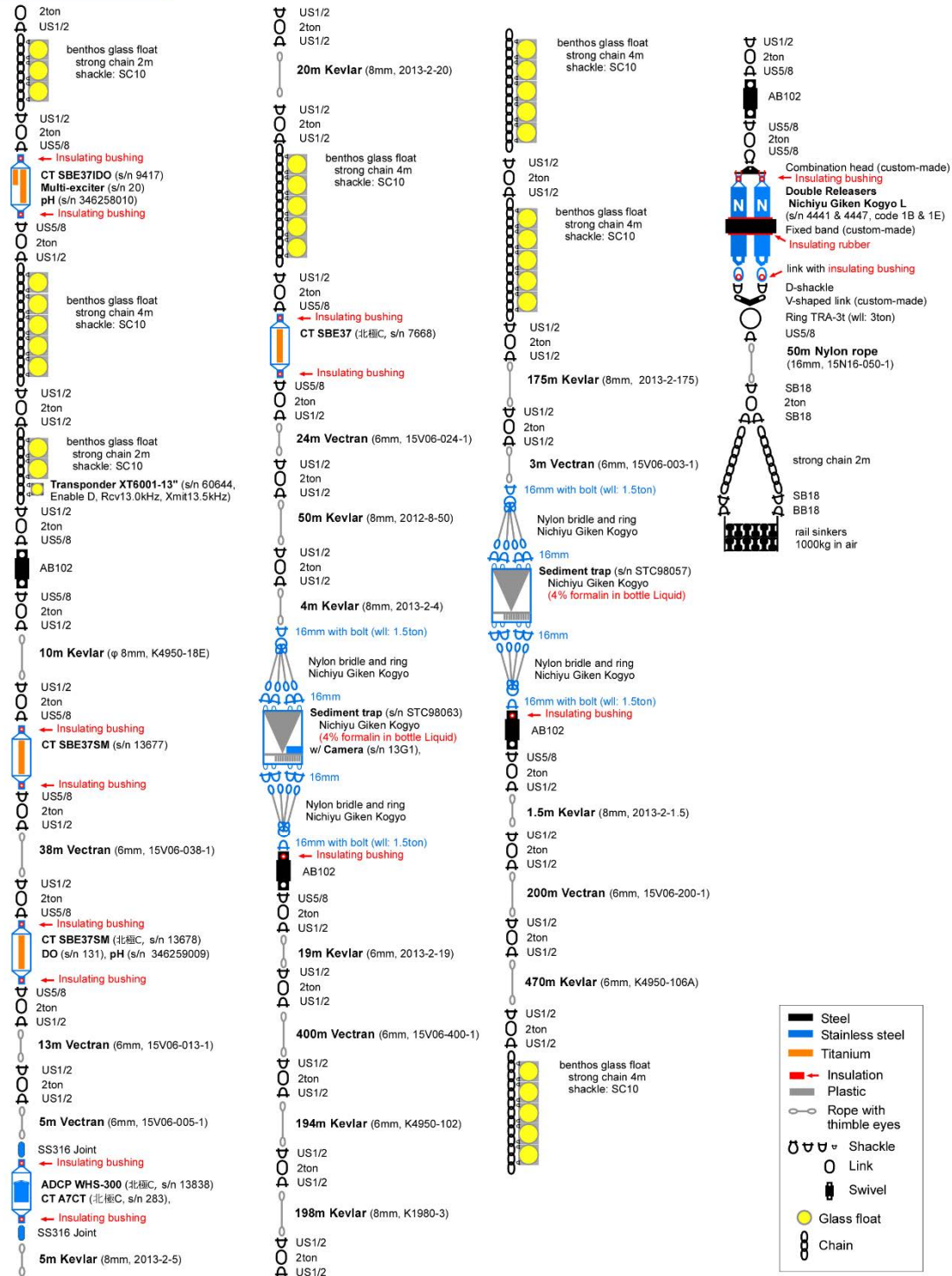

Fig. 4.21-3: The design of sediment trap mooring NBC15t.

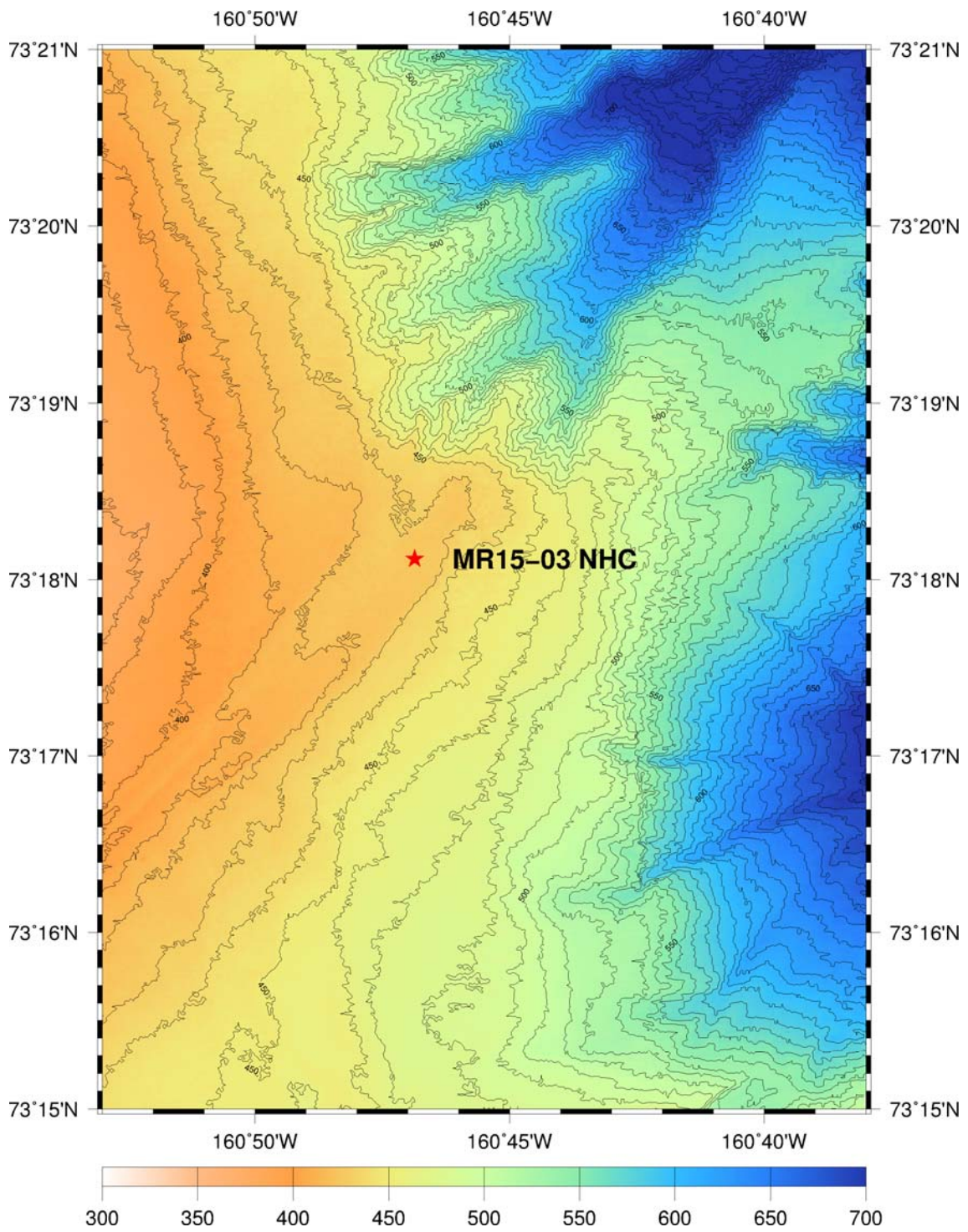

Fig. 4.21-4: Result on bottom survey around Station NHC15t. The red star symbol shows the location of NHC15t.

Deployment

Station NHC15t

73°18.1410'N 160°46.9216'W
425 m water depth, transponder at 53 m

25 Sep. 2015
final version

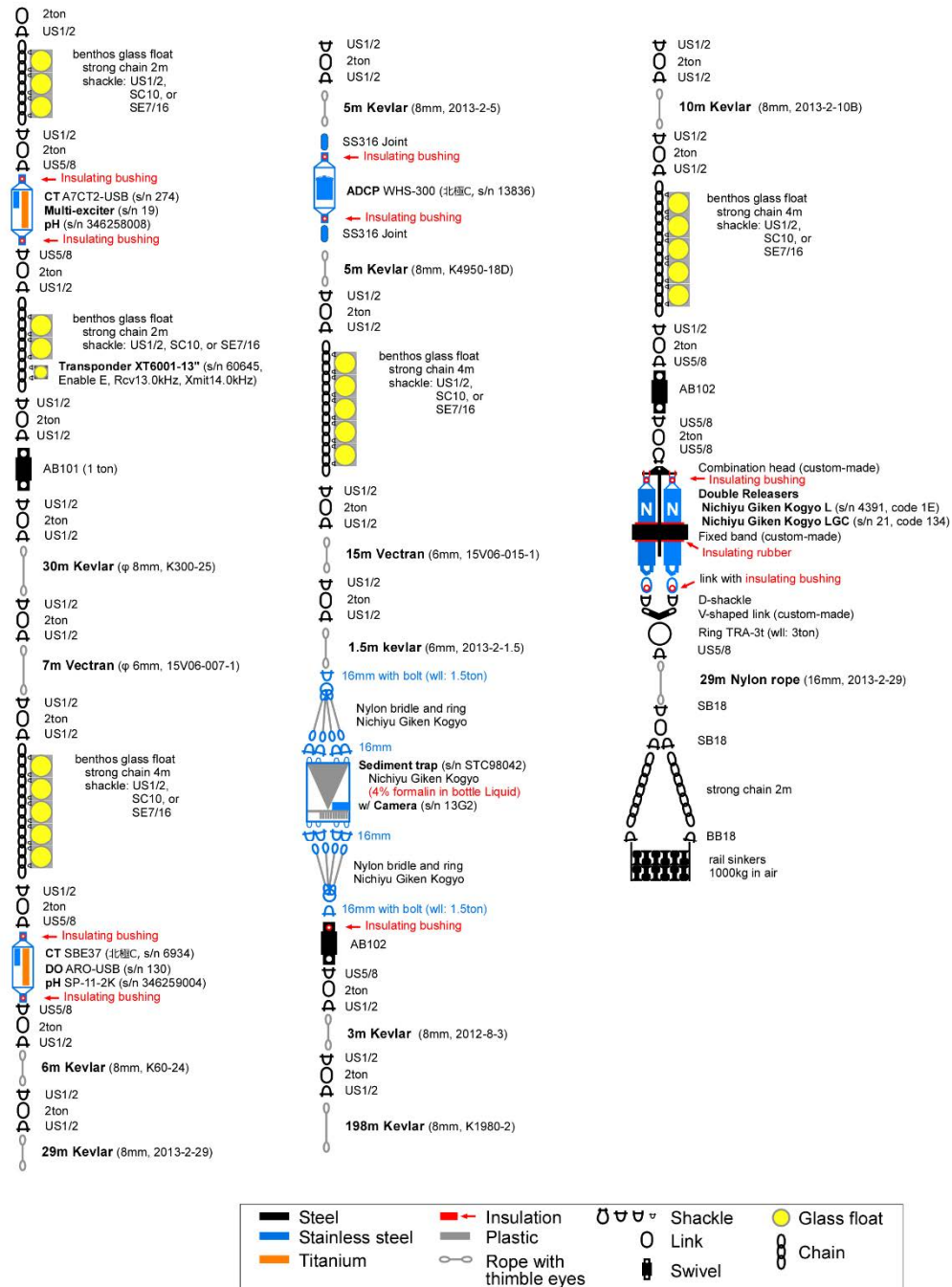

Fig. 4.21-5: The design of sediment trap mooring NHC15t.

5. Geology

5.1. Sea bottom topography measurements

(1) Personnel

Masao Nakanishi	Chiba University: PI	not on-board
Shinya Okumura	Global Ocean Development Inc.(GODI)	Leg1
Wataru Tokunaga	GODI	Leg1
Koichi Inagaki	GODI	Leg1
Souichiro Sueyoshi	GODI	Leg2
Yutaro Murakami	GODI	Leg1, 2
Masanori Murakami	MIRAI Crew	Leg1, 2

(2) Objective

R/V MIRAI is equipped with the Multi narrow Beam Echo Sounding system (MBES; SEABEAM 3012 (L3 Communications ELAC Nautik)) and the Sub-bottom Profiler (SBP; Bathy2010 (SyQwest)). The objective of MBES is collecting continuous bathymetric data along ship's track except shallow depth, to make a contribution to geological and geophysical studies.

(3) Instruments and Methods

The "SEABEAM 3012" on R/V MIRAI was used for bathymetry mapping during this cruise.

To get accurate sound velocity of water column for ray-path correction of acoustic beams, we determined sound velocities at the depth of 6.62m, the bottom of the ship, by a surface sound velocimeter. We made sound velocity profiles based on the observations of CTD, XCTD and Argo float conducted in this cruise by the equation in Del Grosso (1974).

The system configuration and performance are shown in Table 5.1-1 and Table 5.1-2.

Table 5.1-1: SEABEAM 3012 System configuration and performance

Frequency:	12 kHz
Transmit beam width:	2.0 degree
Transmit power:	4 kW
Transmit pulse length:	2 to 20 msec.
Receive beam width:	1.6 degree
Depth range:	50 to 11,000 m
Number of beams:	301 beams (Spacing mode: Equi-angle)
Beam spacing:	1.5 % of water depth (Spacing mode: Equi-distance)
Swath width:	60 to 150 degrees
Depth accuracy:	< 1 % of water depth (average across the swath)

Table 5.1-2: Bathy2010 System configuration and performance

Frequency:	3.5 kHz
Transmit beam width:	23 degree
Transmit pulse length:	0.5 to 50 msec.
Strata resolution:	Up to 8 cm with 300 m of bottom penetration according to bottom type
Depth resolution:	0.1 feet, 0.1m
Depth accuracy:	±10 cm to 100 m, ±0.3% to 6,000 m

(4) Preliminary Results

The results will be published after the primary processing.

(5) Data archives

These data obtained in this cruise will be submitted to the Data Management Group of JAMSTEC, and will be opened to the public via “Data Research System for Whole Cruise Information in JAMSTEC (DARWIN)” in JAMSTEC web site.

<<http://www.godac.jamstec.go.jp/darwin/e>>

5.2. Sea surface gravity measurements

(1) Personnel

Masao Nakanishi	Chiba University: PI	not on-board
Shinya Okumura	Global Ocean Development Inc.(GODI)	Leg1
Wataru Tokunaga	GODI	Leg1
Koichi Inagaki	GODI	Leg1
Souichiro Sueyoshi	GODI	Leg2
Yutaro Murakami	GODI	Leg1, 2
Masanori Murakami	MIRAI Crew	Leg1, 2

(2) Objective

The local gravity is an important parameter in geophysics and geodesy. We collected gravity data during this cruise.

(3) Parameters

Relative Gravity [CU: Counter Unit]
[mGal] = (coefl: 0.9946) * [CU]

(4) Instruments and Methods

We measured relative gravity using LaCoste and Romberg air-sea gravity meter S-116 (Micro-g LaCoste, LLC) during the cruise. To convert the relative gravity to absolute one, we measured gravity, using portable gravity meter (Scintrex gravity meter CG-5), at Sekinehama to Sekinehama port as the reference points.

(5) Preliminary Results

Absolute gravity table is shown in Table 5.2-1

Table 5.2-1: Absolute gravity table of the MR15-03 cruise

No.	Date	UTC	Port	Absolute Gravity [mGal]	Sea Level [cm]	Ship Draft [cm]	Gravity at Sensor * [mGal]	S-116 Gravity [mGal]
#1	23/Aug.	00:39	Sekinehama	980371.94	245	625	980372.90	12669.87
#2	22/Oct.	03:38	Sekinehama	980371.94	248	627	980372.92	12663.36

*: Gravity at Sensor

$$= \text{Absolute Gravity} + \text{Sea Level} \times 0.3086/100 + (\text{Draft} - 530)/100 \times 0.2654$$

(5) Data archives

These data obtained in this cruise will be submitted to the Data Management Group of JAMSTEC, and will be opened to the public via “Data Research System for Whole Cruise Information in JAMSTEC (DARWIN)” in JAMSTEC web site.

<<http://www.godac.jamstec.go.jp/darwin/e>>

5.3. Surface magnetic field measurements

5.3.1. Three-components magnetometer

(1) Personnel

Masao Nakanishi	Chiba University: PI	not on-board
Shinya Okumura	Global Ocean Development Inc.(GODI)	Leg1
Wataru Tokunaga	GODI	Leg1
Koichi Inagaki	GODI	Leg1
Souichiro Sueyoshi	GODI	Leg2
Yutaro Murakami	GODI	Leg1, 2
Masanori Murakami	MIRAI Crew	Leg1, 2

(2) Objective

Measurement of magnetic force on the sea is required for the geophysical investigations of marine magnetic anomaly caused by magnetization in upper crustal structure. We measured geomagnetic field using a three-component magnetometer during this cruise.

(3) Instruments and Methods

A shipboard three-component magnetometer system (SFG1214, Tierra Tecnica) is equipped on-board R/V MIRAI. Three-axes flux-gate sensors with ring-cored coils are fixed on the fore mast. Outputs from the sensors are digitized by a 20-bit A/D converter (1 nT/LSB), and sampled at 8 times per second. Yaw (heading), Pitch and Roll are measured by the Inertial Navigation System (INS) for controlling attitude of a Doppler radar. Ship's position (Differential GNSS), speed over ground and gyro data are taken from LAN every second.

The relation between a magnetic-field vector observed on-board, \mathbf{H}_{ob} , (in the ship's fixed coordinate system) and the geomagnetic field vector, \mathbf{F} , (in the Earth's fixed coordinate system) is expressed as:

$$\mathbf{H}_{ob} = \tilde{\mathbf{A}} \tilde{\mathbf{R}} \tilde{\mathbf{P}} \tilde{\mathbf{Y}} \mathbf{F} + \mathbf{H}_p \quad (a)$$

where $\tilde{\mathbf{R}}$, $\tilde{\mathbf{P}}$ and $\tilde{\mathbf{Y}}$ are the matrices of rotation due to roll, pitch and heading of a ship, respectively. $\tilde{\mathbf{A}}$ is a 3 x 3 matrix which represents magnetic susceptibility of the ship, and \mathbf{H}_p is a magnetic field vector produced by a permanent magnetic moment of the ship's body. Rearrangement of Eq. (a) makes

$$\tilde{\mathbf{R}} \mathbf{H}_{ob} + \mathbf{H}_{bp} = \tilde{\mathbf{R}} \tilde{\mathbf{P}} \tilde{\mathbf{Y}} \mathbf{F} \quad (b)$$

where $\tilde{\mathbf{R}} = \tilde{\mathbf{A}}^{-1}$, and $\mathbf{H}_{bp} = -\tilde{\mathbf{R}} \mathbf{H}_p$. The magnetic field, \mathbf{F} , can be obtained by

measuring $\tilde{\mathbf{R}}$, $\tilde{\mathbf{P}}$, $\tilde{\mathbf{Y}}$ and \mathbf{Hob} , if $\tilde{\mathbf{R}}$ and \mathbf{Hbp} are known. Twelve constants in $\tilde{\mathbf{R}}$ and \mathbf{Hbp} can be determined by measuring variation of \mathbf{Hob} with $\tilde{\mathbf{R}}$, $\tilde{\mathbf{P}}$ and $\tilde{\mathbf{Y}}$ at a place where the geomagnetic field, \mathbf{F} , is known.

(4) Preliminary Results

The results will be published after the primary processing.

(5) Data archives

These data obtained in this cruise will be submitted to the Data Management Group of JAMSTEC, and will be opened to the public via “Data Research System for Whole Cruise Information in JAMSTEC (DARWIN)” in JAMSTEC web site.

<<http://www.godac.jamstec.go.jp/darwin/e>>

(6) Remarks

For calibration of the ship’s magnetic effect, we made “figure-eight” turns (a pair of clockwise and anti-clockwise rotation) at the following period and positions.

03:33 - 03:46 01 Sep. 2015 around 50-06N, 166-07W

04:15 - 04:36 17 Sep. 2015 around 72-21N, 155-20W

20:15 - 20:40 16 Oct. 2015 around 44-00N, 160-30E

08:06 - 08:29 19 Oct. 2015 around 40-16N, 146-56E

5.3.2. Cesium magnetometer

(1) Personnel

Masao Nakanishi	Chiba University: PI	not on-board
Souichiro Sueyoshi	Global Ocean Development Inc.(GODI)	Leg2
Yutaro Murakami	GODI	Leg1, 2
Masanori Murakami	MIRAI Crew	Leg1, 2

(2) Objective

Measurement of the total force of the geomagnetic field on the sea is required for the geophysical investigations of marine magnetic anomaly caused by magnetization in upper crustal structure.

(3) Data Period

00:33 15 Oct. 2015 - 22:02 16 Oct. 2015

(4) Instruments and Methods

We measured the total force using a cesium marine magnetometer (G-882, Geometrics Inc.) and recorded by G-882 data logger (Ver.1.0.0, Clovertech Co.). The G-882 magnetometer uses an optically pumped Cesium-vapor atomic resonance system. The sensor fish towed 500 m behind the vessel to minimize the effects of the ship's magnetic field. Table 5.3-1 shows system configuration of MIRAI cesium magnetometer system.

Table 5.3-1: System configuration of MIRAI cesium magnetometer system

Dynamic operating range:	20,000 to 100,000 nT
Absolute accuracy:	< ±2 nT throughout range
Setting:	Cycle rate; 0.1 sec
	Sensitivity; 0.001265 nT at a 0.1 second cycle rate
	Sampling rate; 1 sec

(5) Data archives

These data obtained in this cruise will be submitted to the Data Management Group of JAMSTEC, and will be opened to the public via “Data Research System for Whole Cruise Information in JAMSTEC (DARWIN)” in JAMSTEC web site.

<<http://www.godac.jamstec.go.jp/darwin/e>>

6. Notice on using

This cruise report is a preliminary documentation as of the end of the cruise. This report may not be corrected even if changes on contents (i.e. taxonomic classifications) may be found after its publication. This report may also be changed without notice. Data on this cruise report may be raw or unprocessed. If you are going to use or refer to the data written on this report, please ask the Chief Scientist for latest information.

Users of data or results on this cruise report are requested to submit their results to the Data Management Group of JAMSTEC.